

UIM  
2026

MOTOSURF  
RULEBOOK

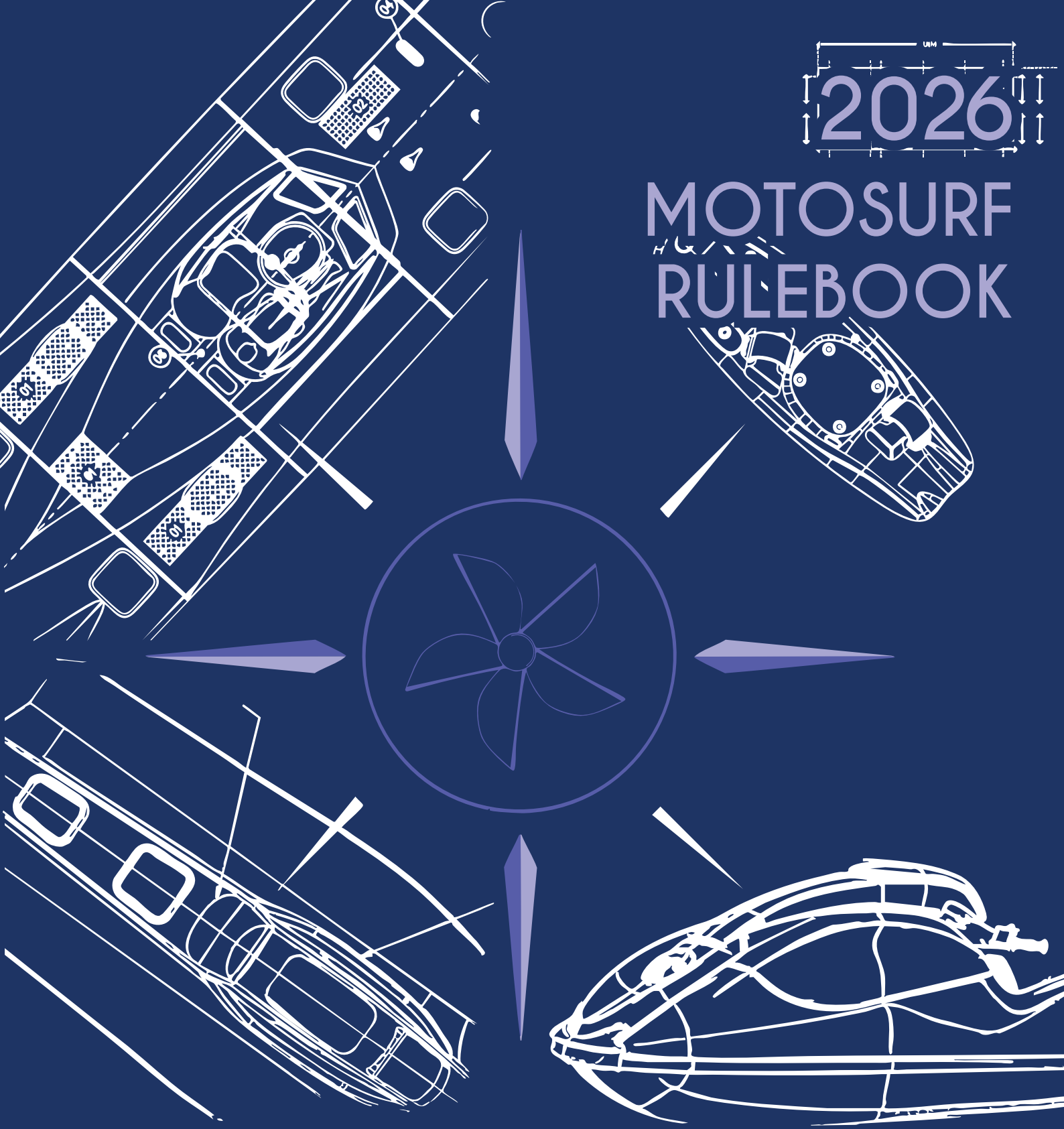

UIM   
UNION INTERNATIONALE MOTONAUTIQUE



**Elite Class**



**Matyáš NOVOTNÝ**  
CZECHIA

**Women Class**



**Eliška MATOUŠKOVÁ**  
CZECHIA

**Stock Class**



**Antony SQUIRE**  
USA

**Stock R -  
Merlin Plus Class**



**Mike MICHAELIDES**  
CYPRUS

**Masters**



**Down KIM**  
SOUTH KOREA

**Electric Challenge**



**Yano VANKERSBILCK**  
BELGIUM

**Junior Boys**



**Matyáš BARVÍK**  
CZECH REPUBLIC

**Junior Girls**



**Ellen BURDOVÁ**  
CZECH REPUBLIC



# **MOTOSURF RULES 2026**

**PUBLISHED ON 05/03/26**

**CORRECTION PUBLISHED ON 20/05/26**  
**(page 19, Art.302, Long Lap)**

## TABLE OF CONTENTS

<b>MOTOSURF RULES 2026</b> .....	<b>3</b>
<b>100 - GENERAL OVERVIEW &amp; PARTICIPATING PARTIES</b> .....	<b>7</b>
101 - UNION INTERNATIONALE MOTONAUTIQUE (UIM) .....	7
102 - PROMOTER (MSWC) .....	7
103 - NATIONAL AUTHORITY (NA) .....	7
104 - EVENT ORGANIZER .....	7
105 - RACE DIRECTION .....	7
106 - EVENT STAFF .....	7
107 - MANUFACTURERS .....	8
108 - RIDERS .....	8
109 - SAFETY STAFF .....	8
110 - UIM COMMISSIONER.....	8
111 - RIDERS' COMMITTEE .....	9
<b>200 - GENERAL RULES</b> .....	<b>10</b>
201 - RACER REGISTRATION .....	10
202 - RACING LICENCES .....	10
203 - ADVANCE PROGRAMME .....	12
204 - RACE ENTRY FEE.....	12
205 - EVENT STAFF .....	13
205.01 - O.O.D (OFFICER OF THE DAY).....	13
205.02 - SPORT DIRECTOR .....	13
205.03 – TIMEKEEPER .....	13
205.04 - VIDEO REFEREE .....	13
205.05 - TRACK OBSERVERS .....	13
205.06 - START MARSHAL .....	13
205.07 - FLAG MARSHAL .....	13
205.08 - PITS AREA COORDINATOR .....	13
205.09 - TECHNICAL SCRUTINEER .....	14
205.10 - MEDICAL DIRECTOR .....	14
205.11 - RESCUE TEAM .....	14
205.12 - FACILITY DIRECTOR .....	14
206 - RIDERS' ORGANIZATION .....	14
207 - PARC FERMÉ PROCEDURE – ONLY MOTOSURF WORLD CHAMPIONSHIP .....	15

<b>300 - SPORT RULES</b> .....	<b>17</b>
301 – CATEGORIES .....	17
301.01 - ELITE MEN .....	17
301.02 - ELITE WOMEN .....	17
301.03 - STOCK MEN .....	18
301.04 - MASTERS MEN .....	18
301.05 - MASTERS WOMEN.....	18
301.06 - JUNIORS BOYS .....	18
301.07 - JUNIORS GIRLS.....	18
301.08 - ELECTRIC CHALLENGE .....	19
301.09 - EXCEPTIONS .....	19
302 - THE TRACK, GENERAL DESCRIPTION .....	19
303 – RACE TRACK SAFETY .....	22
304 - FINISH GATE .....	23
305 - STARTING BLOCK .....	24
306 - TRACK LENGTH – MOTOSURF WORLD CHAMPIONSHIP ONLY .....	24
307 - LAP CHART.....	24
308 - TRACK PROFILE CHANGES DURING A SESSION .....	24
309 - FLAG SIGNALS .....	26
310 - LAPS SIGNALS .....	27
311 - PROPER RIDE DEFINITION.....	27
312 - STARTING PROCEDURE.....	27
313 - ANNOUNCEMENT OF THE STARTING METHOD.....	30
314 - THE PRACTICE START.....	30
315 - RESTART .....	30
316 - ACKNOWLEDGEMENT AFTER LAST VALID LAP BEFORE RESTART .....	30
317 - RACE PENALTIES .....	31
318 - RACE FORMAT.....	33
319 - SCORING .....	37
320 - THE WINNER & PODIUM CEREMONY .....	38
321 - EVENT SCHEDULE .....	38
322 - NUMBER OF GROUPS.....	42

<b>400 – JURISDICTION</b> .....	<b>43</b>
401 - DEFINITIONS .....	43
402 - JUDICIAL BODIES .....	43
402.01 – THE PROTEST JUDGE .....	43
403 - PROTEST PROCEDURES .....	43
404 - HEARING OF THE PROTEST .....	45
405 - THE APPEALS PROCEDURE .....	46
406 - UIM PENALTIES .....	48
407 - PRIORITY OF THESE RULES .....	50
409 - ARBITRATION .....	50
<b>500 - TECHNICAL RULES</b> .....	<b>51</b>
501 - ELITE MEN & MASTERS MEN CATEGORIES .....	51
502 - STOCK MEN CATEGORY .....	52
503 - ELITE WOMEN & MASTERS WOMEN CATEGORIES .....	55
504 - JUNIORS BOYS & JUNIORS GIRLS CATEGORIES .....	57
505 - ELECTRIC CHALLENGE CATEGORY .....	58
506 - ADDITIONAL RULES FOR STOCK MEN AND ELITE WOMEN CATEGORIES .....	60
507 - TECHNICAL INSPECTION OF SAFETY GEAR .....	61
508 - TECHNICAL INSPECTION IN PARC FERME .....	61
<b>600 - RECORDS AND PERFORMANCES</b> .....	<b>63</b>
<b>700 - ENVIRONMENTAL REGULATIONS</b> .....	<b>63</b>
<b>800 - BASIC SERVICES AT THE EVENT – MOTOSURF WORLD CHAMPIONSHIP</b> .....	<b>63</b>
<b>900 - E-FOIL MASTERS (SEPARATE EVENT)</b> .....	<b>64</b>
<b>1000 - NATIONS CUP</b> .....	<b>68</b>
<b>APPENDIX 1 – DEFINITIONS AND SCHEMES</b> .....	<b>72</b>
<b>APPENDIX 2 – JETSURF TITANIUM TECHNICAL SPECIFICATIONS</b> .....	<b>74</b>
<b>APPENDIX 3 – JETSURF RACE DFI TECHNICAL SPECIFICATIONS</b> .....	<b>95</b>
<b>CODE OF ETHICS 2026</b> .....	<b>114</b>
<b>ANTI-DOPING RULES 2026</b> .....	<b>121</b>
<b>ENVIRONMENTAL CODE 2026</b> .....	<b>182</b>

## **100 - GENERAL OVERVIEW & PARTICIPATING PARTIES**

MotoSurf is a racing discipline of motorized surfboards racing. Since 2019, this discipline has been part of the UIM.

MotoSurf is organized in several categories: Elite **Men**, **Elite Women**, Stock **Men**, Masters **Men**, **Masters Women**, Juniors Boys, Juniors Girls and Electric Challenge. The fully electric surfboards are divided into two main disciplines, MotoSurf Electric Challenge and e-Foils Masters.

### **101 - UNION INTERNATIONALE MOTONAUTIQUE (UIM)**

The UIM is an International Federation, fully recognized by the International Olympic Committee, governing all motorized water sports worldwide. The UIM is responsible for the organisation, administration, governance and development of all international powerboat activities, including the motorized surfboards World Championship and Continental Cup Championships.

### **102 - PROMOTER (MSWC)**

The Promoter is the authorized entity by the UIM for organization of the World Championship and Continental championships and is responsible for governing and administration of the events and also communication with the riders and organizers of the World Championship and Continental level events. The Promoter together with the UIM MotoSurf Committee is responsible for forming the rulebook, creating advance programme, paddock organization and all formal administration of the event. The UIM cedes all the rights related to the organization of the UIM MotoSurf World and Continental Championships to the Promoter for further exploitation.. The Promoter is responsible for running the event in terms of compliance with the official UIM MotoSurf rules. The promoter is responsible for securing a sufficient number of judges and authorized personnel in order to deliver the event in accordance with the UIM rulebook.

### **103 - NATIONAL AUTHORITY (NA)**

National Powerboating Authority, a member of the UIM.

### **104 - EVENT ORGANIZER**

A partner of the Promoter in terms of hosting and administration of the event. The Organizer works under the control of the Promoter based on an agreement.

### **105 - RACE DIRECTION**

Race direction is a group of officials that control the event according to current UIM rules. The Race Direction is appointed by the Promoter. The Race Direction includes the following roles:

- O.O.D.
- **Sport Director**
- Time Keeper
- **Video referee**
- **Technical Scrutineer**

### **106 - EVENT STAFF**

- **Facility Director**
- **Pit Area Coordinator**
- **Medical Director**
- **Flag Marshal**
- **Manufacturer's Commissioner**
- **Start Marshal**

## 107 - MANUFACTURERS

A manufacturer is every surfboard producer participating in the Championship ***based on homologation of the Promoter & UIM. Homologation criteria and period for homologation shall be published on the UIM website.***

## 108 - RIDERS

Participants of the events being on control of their surfboards on the water that are properly registered for each event complying with all administration procedures as in valid UIM rules and instructions of the Promoter & Event organizer.

## 109 - SAFETY STAFF

To ensure maximum safety for every event, it is necessary that there is safety staff present that includes:

- a. Doctor – necessary part of the safety staff for each event. The doctor is a person in charge of on-shore health care. Without a doctor, none of the session of the event can start. If at any point during the event the doctor has to leave the race venue because of an emergency case occurred during the event, the water then becomes closed.
- b. Ambulance Crew – responsible for necessary health measurements and transportation of injured person to the nearest hospital. At least one ambulance and crew must always be present at the race venue. Without an ambulance present on-site, none of the scheduled sessions can be started.
- c. On-water rescue team – during the sessions, it is necessary that there is a rescue team for on-water operations. In case of emergency, on-water rescue conducts the action towards health protection. On-water rescue personnel work in cooperation with the doctor, ambulance and race direction.

## 110 - UIM COMMISSIONER

### 110.01 - GENERAL DESCRIPTION

The presence of a UIM Commissioner is required at any International titled meeting. The function of the Commissioner must be fulfilled most carefully. As soon as UIM gets the Commissioners agreement, the Secretary General of the UIM will send a letter to the National Authority informing them that the Commissioner has been designated for the events referred in the letter.

No Commissioner will be appointed to an Event organised by his/her National Authority, unless a derogation agreed by MotoSurf Committee.

The UIM Commissioner sent to the competitions must come from a Nation near to the organizing one and not from different continents.

National Authorities are requested to send yearly to the UIM Secretariat a list of candidate Commissioners with the following data:

- Name, address, telephone, and e-mail
- Languages spoken
- languages read and understood
- At what times the candidate is at disposal
- Knowledge in sports and technical matters

An UIM Commissioner shall be chosen by the UIM Secretary General in coordination / consultation with the chairperson of the MotoSurf Committee from the listings provided by National Authorities and by the MotoSurf Committee. The UIM commissioner cannot be appointed to an Event organised by his/her own National Authority unless by special reasons.

#### **110.02 - FUNCTIONS OF THE UIM COMMISSIONER**

- a) Assist the local organiser and more particularly the O.O.D.
- b) Approve last minute amendments to the advance – programme
- c) Ensure that the course is in accordance with the water registration
- d) Take part in important decision making during the race with Race Direction.
- e) Take part in urgent decision making with the Race Direction
- f) Take part in urgent decision making with the Race Direction and the organising promoter, in matters related to the overall organisation.

#### **110.03 - UIM COMMISSIONERS GUIDELINES**

On the day prior the first race / practice day, a meeting shall be held between the UIM Commissioner and the race organizers / officials, and the promoter to review all aspects of the race organization. Time for the meeting will be at 18:00, unless otherwise agreed.

#### **110.04 - AFTER THE RACE RESPONSIBILITIES**

As soon as the results are verified, the National Authority and the UIM Commissioner forwards these results to the UIM Secretariat.

After the event, the UIM Commissioner sends his/her report to the UIM Secretariat by using the official form, within ten days after the race. The official results of the Event must be enclosed with the report. The reports are considered as confidential matter and cannot be used for aims other than UIM's.

#### **110.05 - ACOMMODATION AND TRAVEL EXPENSES**

Travel expenses must be compensated by the organizers to the Commissioner from his/her place of residence to the race venue on basis of return air ticket, economy class. If the organisers do not offer daily meals and local transportation to the Commissioner, they must be paid actual costs or a minimum of 60 euro per day.

#### **111 - RIDERS' COMMITTEE**

At the first briefing of each racing weekend, the riders elect the "**Riders' Committee**", which consists of three persons representing three different categories. This Commission communicates with the O.O.D. in terms of safety reasons for the event and decisions made in unusual situations that occur during the event.

In case the riders do not elect the three representatives, the Commission of Riders is nominated by the O.O.D.

## **200 - GENERAL RULES**

### **201 - RACER REGISTRATION**

*Rider registration takes place at the location and time specified in the preliminary program published before the event. The preliminary program and registration are available on the organizer's website.*

*A Rider who did not go through the registration process will not be allowed to participate at any session during the race weekend. To complete the registration process, every rider has to pay the entry fee for the race. Such entry fee will be specified in the advance program published prior to the event.*

*The instructions about registration will be sent by the Promoter.*

*Every rider must have an international licence issued by his/her national powerboating authority that is a member of the UIM. Every rider needs to have a private insurance for extreme sports. The third party liability insurance is covered by the Promoter.*

*Every rider shall fill the registration form and sign a waiver of participation at the event.*

*Each rider must register for the category compliant with the age and skill range each category is designed for.*

*A Rider under 18 years of age has to deliver an official form signed by his/her legal representative. Such form will be provided by the Promoter of the event upon request or will be available in the advance programme sent prior to the event.*

*In case there is a rider below the minimum age for the category he/she is applying to, legal guardian can ask the Promoter for exception. Such exception is granted solely based on decision of the Promoter. Start number assignment as per the official website of the Promoter.*

### **202 - RACING LICENCES**

#### **202.01 - COMPULSORY LICENCE**

*No one can take part in a UIM race, establish or improve a UIM record in International class boats, without being in Possession of an International licence from his/her National Authority. In order to obtain an International licence or Super Licence, following disclaimer must be signed by the licence holder: "The undersigned... Licensed pilot (licence n° ), participating in UIM sanctioned events, yields the media rights of any coverage by the promoter taken during the Event, to the UIM for further use by press, radio or television. The right however remains the property of the undersigned".*

*In addition, I herewith agree and acknowledge the following:*

*UIM is the governing rule making body of UIM racing events which are responsibly organized by clubs, national authorities of UIM, contracted promoters or other organizers. These organizers do not act on behalf of the UIM and UIM is not responsible for any act or omission of such organizer and shall not be liable to the participant accordingly.*

*The UIM sport and technical rules are intended to minimize risks but they cannot provide the highest possible safety standards at all times. Residual risks might remain.*

*Enforcement of the rules by UIM or other race officials and in particular but not limited to the technical scrutineering does not guarantee the safety of racing or the safety of the scrutineered boat. Scrutineering is not intended as a construction/ condition survey. The racing license issued by the National Authority or a super license issued by the UIM does not guarantee that a rider is physically able to race safely nor that he/she has sufficient experience or education.*

*Teams and riders are solely responsible for their own safety including but not limited to their physical and educational ability to race in the relevant class, the safety of their boats and other gear and the safety of their racing activity. This responsibility includes racing with prudence and taking technical measures which are not mandatory in the rules but deemed necessary.*

*UIM shall not be liable for any damage, injury or death due to inadequate rules, breach of existing rules by participants or failure to enforce rules by the race officials.”*

*The signed disclaimer can be requested by the UIM commissioner at any UIM sanctioned event.*

## **202.02 - REGISTRATION**

*The National Authority establishes each year a list of people to whom International licences have been delivered and this must be sent to the UIM Secretariat. The list must include: the name and surname, the address and email, the class(es) for International Licence only and the Anti-Doping Consent Form of UIM Anti-Doping Rules duly signed for acceptance. Any Person wishing to obtain a licence must apply to the National Authority through his/her club.*

*The licence is granted by the National Authority and is marked “International” as decided by the National Authority. Licence holders must have a current UIM rule book.*

*Any National Authority has the right to deliver licences to:*

*- its nationals*

*- nationals of another country affiliated to the UIM only with the written agreement of the National Authority of that nation.*

*With the approval of the UIM a National Authority may also deliver licences to Persons belonging to a country which is not yet affiliated to the UIM. Riders are only permitted to hold licences from one National Authority. A National Authority may refuse to give a licence without having to state the reason. Notification of this is sent to all affiliated clubs and to the UIM.*

*Severe sanctions should be applied by national authorities that do not comply with.*

### **202.03 - VALIDITY OF LICENCES**

*Licences are valid from the 1st of January until the 31st of December each year, unless local circumstances require other dates, but validity should always be shown on the licence itself, and must be for one year. A licence is valid in any country affiliated to the Union and entitles the holder to enter or drive in his/her boat in all competitions organised in any affiliated country, provided he/she complies with what is stated in the UIM general racing rules. However, for any Event held under special rules, the licence holder must abide by the rules in question.*

### **202.04 - COST OF LICENCE**

*The cost of the yearly licence is to be fixed by the National Authority.*

### **202.05 - EXAMINATION OF LICENCES**

*At any meeting, the holder must produce his/her licence at the request of any official of the meeting.*

### **202.06 – CANCELLATION OF LICENCE**

*Intentionally left blank*

### **202.07 - PSEUDONYM**

*The Use of a pseudonym must be requested to the National Authority and the National Authority marks the pseudonym on the licence.*

*A licence holder, as long as he/she is listed under a pseudonym, may not take part in any sports Event under any other name.*

*Changing a pseudonym is subject to the same formalities as the adoption of it. Anyone who has chosen a pseudonym may not return to his/her actual name until the National Authority has agreed and has delivered a new licence. The rider may only race under his/her name or the pseudonym written on the licence.*

## **203 - ADVANCE PROGRAMME**

*The Promoter shall publish an Advance Programme no later than 60 days prior to the Event, in order to inform all riders about important facts regarding the event organization. Every rider has to confirm to the Promoter their participation at the event as specified in the Advance Programme.*

## **204 - RACE ENTRY FEE**

*Race entry fee shall be defined in each Advance Programme before every event.*

## 205 - EVENT STAFF

### 205.01 - O.O.D (OFFICER OF THE DAY)

Officer of the Day is responsible for supervising racing matters happening in accordance with the official rulebook of the race. Officer of the Day has the main decision-making right regarding the race format and organization schedule. Officer of the Day is authorized to change/update the schedule, cancel the session and the entire event. Officer of the Day communicates with the representatives of the **Riders' Committee**. Officer of the Day is responsible for the camera system observing the race track during the sessions.

### **205.02 - SPORT DIRECTOR**

Carries out the inspection of the time keeping of the qualification. **Sport Director** is responsible for carrying out racing matters in accordance with the rules of the race and may suggest interruption or cancelling of a session. **Sport Director** is responsible for carrying out the communication with riders, **preparation of entry lists and** publishing the results and all race information. **Sport Director is responsible for sport coordination on the water as well as draft of the Race Course and for the building coordination.**

### 205.03 – TIMEKEEPER

Carries out the time keeping of the qualification and all heats and finals, performs digital/manual recording of the qualification and all heats and finals. The Timekeeper is always backed up in time keeping by a second person (might be O.O.D) who backs up time keeping by manual keeping and recording the lap times into the race weekend records.

### **205.04 - VIDEO REFEREE**

**Video referee is responsible for providing evidence of happened situations during the official session. Such evidence serve to Race Direction or Protest Judge in order to evaluate protests or penalties.**

### 205.05 - TRACK OBSERVERS

Observes the riders on the track whether they ride the race in conformity with the rules. Based on the track observing, the Track Referee informs the O.O.D about any incorrect riding actions. Such actions shall be verified on the camera recordings so that the O.O.D. may impose penalties, if applicable.

### 205.06 - START MARSHAL

Carries out the starting procedure; the start marshal may cancel the heat or the Final or call a restart procedure. **Start marshal acts in close cooperation with Race Direction and under supervision of the O.O.D. and Sport Director.**

### 205.07 - FLAG MARSHAL

The Flag marshal is responsible for the flag signalization and for the signalization of the number of remaining laps in each particular session. The Flag Marshall is in radio contact with **Race Direction**.

### 205.08 - PITS AREA COORDINATOR

Prepares the riders for the start and assists at the starting procedure. Ref Art. 1.6

## 205.09 - TECHNICAL SCRUTINEER

The Technical scrutineer is in charge of technical affairs at the race. Technical check and rider's equipment check is the main task of the Technical scrutineer as well as supervising the service department at each given venue.

## 205.10 - MEDICAL DIRECTOR

The Medical director is authorized to declare a rider fit or unfit for participation in a given session/part of the weekend/whole weekend.

## 205.11 - RESCUE TEAM

The Rescue Team is responsible for operations on the water. There has to be at least one rescuer on the water every time the session is underway. The Rescue Team is in constant contact with the O.O.D. The Rescue Team can request a session interruption, delay or cancellation in case of emergency. More roles can be carried out by one person in case such person is qualified enough, experienced and capable of executing such role. In case the event scale does not require so, some of the roles may remain unoccupied. The above-mentioned circumstances are evaluated and decided by the O.O.D.

## 205.12 - FACILITY DIRECTOR

*The Facility Director is responsible for the preparation of the race venue, including track setup, the riders' support area (paddock), and the parc fermé. The Facility Director shall ensure that all facilities are ready and fully functional to support a smooth race, both for racers and for race direction. Responsibilities include maintaining order throughout the venue, providing functional supplies during the event, ensuring a clean environment, and implementing a proactive environmental approach towards the race venue.*

## 206 - RIDERS' ORGANIZATION

### 206.01 – GENERAL

Riders shall comply with the O.O.D instructions and strictly follow the provisions of the rulebook. In case of a breach of the rules or not complying with the **Race Direction or Promoter's** instructions the rider may be penalized. Riders that are planning to take part in the race, must complete the registration within the registration deadline and settle the race entry fee. Registration must be finished within the time announced in the Advance Programme. Late registration will not be accepted. Each rider has right to request an extra time of arrival to the race and making the registration and technical inspection. This right can be used only once per season. In case it's the first race of a riders, in such case, the exception cannot be granted.

Registration – technical inspection of motorized surfboard, safety equipment inspection, license check, payment of the race entry fee, distribution of the race schedule, receiving distinguishing shorts (obligatory to wear during races throughout the racing weekend). The riders are obliged to watch the event information table administered by the **Sport Director**. The riders shall check the time schedule and riders groups entry lists to know which group they are part of. According to information from the entry lists, they shall also be aware of receiving **time keeping transponder & holder**, distinguishing shorts that are usually passed/changed/reclected during the morning/midday/debrief session.

Registered riders are required to attend all briefings and sessions according to the official event schedule. In case of a rider's unexcused absence, such rider will not be allowed to enter the race track. Each rider is obliged to be ready for the briefing session 15 minutes before it starts. Every rider is obliged to sign the presence list. If anybody is proved for signing another rider, both riders will be

penalized. Riders are required to watch for all flag signals on the track. If a rider does not respect a flag signal, such action may be penalized according to Irresponsible Riding. Riders are not allowed to enter the track without the Pits Area Coordinator's approval. In case of infringement, the rider will be penalized.

The O.O.D. or **Sport Director** shall inform the riders about the current status of the race, they shall transmit the information necessary for the racing weekend to run smoothly. Afterwards there will be a time space for questions which will be answered by the Race Direction. Any communication between Race Direction and the riders takes place only at the level of the O.O.D. with the "Commission of Riders". The decision of the O.O.D. is final. O.O.D. and **Sport Director's** tent is closed for all the riders and individuals. All protests need to be submitted via the Protest Judge latest 60 mins after publishing of the unofficial results. The protests will be dealt in the time window announced in the time schedule. O.O.D. and **Sport Director** may use electronic methods of communication for faster publishing and communication of the results and racing information.

## **206.02 - ANTI-DOPING AND SAFETY MEASURES**

### **206.02.01 - PRE-RACE INJURY**

***Any Rider recovering from injury or rider that has been injured but still intends to participate in the event, has to contact the Sport Director and the Medical Director at least seven days before the event. Medical Director is authorized to request medical reports and evaluate declaration of state – fit / un-fit to race. The final declaration of fit / un-fit shall be stated latest one day before the first official session of the event starts.***

### **206.02.02 - ALCOHOL TESTING**

***The O.O.D., Race Secretary, Protest Judge or Promoter may, through medical staff, require any participant to undergo alcohol testing at any time. Tests are performed by medical staff and results reported to Race Direction. A positive test or refusal to comply is deemed a breach of the rules and results in immediate disqualification from the event. If a participant is disqualified for a positive test more than once in a season, they are suspended from all remaining events of the Championship for that season.***

### **206.02.03 - ANTI-DOPING MEASURES**

The Anti-doping regulations are based upon the world anti-doping Code. The valid Anti-Doping code for the UIM MotoSurf International events is WADA (World Anti-Doping Agency). List of prohibited methods and substances to be found at: <https://www.wada-ama.org/en/content/what-is-prohibited>

## **206.03 - COMMUNICATION WITH RACE DIRECTION**

The **Riders Committee** communicates with the the O.O.D. on behalf of the riders. ***Communication with the O.O.D. or Sports Director is permitted only within the framework of Race Direction. Riders are not permitted to communicate individually with referees during the race weekend, except when submitting a protest.***

## **207 - PARC FERMÉ PROCEDURE – ONLY MOTOSURF WORLD CHAMPIONSHIP**

### **207.01 - BEFORE THE SESSION**

The riders put their board on the stands according to their order on the entry list for the upcoming session. ***The motorized surfboard of the rider has to be deactivated.***

### **207.01.01 - FORBIDDEN ACTIONS IN THE PARC FERME AREA**

- a. Start the engine without the guard officer's instruction
- b. Manipulate the board in an inappropriate way that causes damage to the standing board
- c. Manipulate the board in a way that may cause injury to other competitors
- d. To refuel
- e. To make repairs
- f. Riders have to line up into the parc fermé area on time to prevent delays.
- g. In case of practices, riders from other groups shall wait at least 5 minutes before the previous group finishes their practice, to enter the parc fermé area as soon as possible.
- h. In case of heats, riders from other group shall wait at least 5 minutes before the previous group finishes their practice, to enter the parc fermé area as soon as possible.
- i. In case of F1, riders shall wait at least 5 minutes before the particular final starts.

### **207.01.02 - PRELIMINARY CHECK OF THE BOARDS**

Before each new session, the Technical Scrutineer has right to conduct a check of the board to ensure its compliance with the technical specifications. In case of suspicion, the Technical Scrutineer is authorized to:

- Interrupt the procedure, request delay for further analysis of the technical conditions of the board and its compliance with the technical regulations. In case the board is not compliant with the technical regulations for each particular category, the rider is immediately disqualified from the entire event and all his/her points are nullified. In case the surfboard is compliant with the technical regulations, the procedure continues and the rider enters the upcoming session.

- Let the procedure to continue and conduct the technical check of the surfboard after the particular session. The board shall be taken to the parc fermé immediately after finishing the session where the Technical Scrutineer conducts the technical check. In case the board is not compliant with the technical regulations for particular category where the rider starts, the rider is disqualified from the entire event and all so far collected points are nullified. In case the board is compliant with the technical regulations for the particular category, the rider normally continues in the event.

### **207.02 - AFTER THE SESSION**

After the session the boards will be checked immediately after Heats and Finals sessions. The riders that finished their ride will bring the boards back to the Parc Fermé at earliest possible convenience. It is forbidden to bring the board back to the paddock without going through the Parc Fermé.

Within the limit of 6 minutes, the board is inspected. It is decided whether the machine is OK, technically does not meet the given category, or if there are further doubts meaning that the machine must be examined in more detail.

The Technical Scrutineer is authorized to take a sample of fuel for further analysis to check compliance with the fuel regulations. Breaching the rule of the equal fuel provided by the organizer will be penalized by O.O.D. based on decision of the Technical Scrutineer. The Technical Scrutineer has right to DSQ the rider from the session after which the discrepancy was found or from the entire event.

If there is a breach to rules found during the Parc Fermé After the session check and the Technical Scrutineer announced further action on such board, such board has to remain in Parc Fermé until the moment the Technical Scrutineer takes further action.

### **207.03 - SUPERVISION OF THE BOARD IN CASE OF TECHNICAL RULES BREACH**

*A motorized surfboard suspected from a technical rules breach, which can only be verified only by dismantling, will remain in a protected mode, just like the drawn surfboards, until the end of the race / race day and verification. Subsequently, all repairs and modifications will only be made with the consent and participation of the technical commissioner. At the time window announced by the Technical Commissioner, the motorized surfboard will be dismantled and in case of a violation of the rules, all results from the on-going event will be cancelled.*

## **300 - SPORT RULES**

### **301 – CATEGORIES**

*A rider can only compete in one category during a racing weekend, with exception of the Electric Challenge category.*

#### **301.01 - ELITE MEN**

*The Elite Men category is open to riders of male biological gender who have reached a minimum age of sixteen (16) years within the relevant calendar year.*

*Eligibility to compete in the Elite Men category is conditional upon the rider having successfully completed at least one (1) officially recognized race in the Stock Men category during the preceding competition year. A rider competing in the Elite men category having finished in Top 8 in the previous season and is younger than 40 years may only compete in the Elite Men category in the next following season.*

*A rider having competed in two or more rounds in the Elite Men category must remain in this category until the season finishes.*

*An exception to these requirements may be granted at the sole discretion of the Motosurf Committee, based on the rider's demonstrated experience, performance level, or other relevant considerations.*

*The category is open in terms of manufacturers' plurality. Performance tuning is allowed according to Paragraph 8 of the rulebook (Technical inspection). Further specifications can be found in section 7.1. of the rulebook.*

#### **301.02 - ELITE WOMEN**

*The Elite Women category is open to riders of female biological gender who have reached a minimum age of sixteen (16) years within the relevant calendar year.*

*The category is closed from a manufacturer perspective, the only accepted board specifications are JetSurf Race DFI 2021 and newer JetSurf DFI models. Further specifications can be found in sections 7.5 and 8. of the rulebook.*

**301.03 - STOCK MEN**

*The Stock Men category is open to riders of male biological gender who have reached a minimum age of fifteen (15) years within the relevant calendar year.*

*A rider who wins the overall season championship in the Stock Men category shall not be eligible to compete in the Stock Men category in the next following season. Such rider shall be automatically promoted to the Elite Men category, unless otherwise determined by the MotoSurf Committee.*

*The category is closed from a manufacturer perspective, the only accepted board specifications are JetSurf Titanium DFI 2021 and newer JetSurf Titanium DFI models. Further specifications can be found in sections 7.4 and 8. of the rulebook.*

**301.04 - MASTERS MEN**

*The Masters Men category is open to riders of male biological gender who have reached a minimum age of forty (40) years within the relevant calendar year.*

*The category is open in terms of manufacturers' plurality. Performance tuning is allowed according to section 8 of the rulebook (Technical inspection). Further specifications can be found in section 7.1. of the rulebook.*

**301.05 - MASTERS WOMEN**

*The Masters Women category is open to riders of female biological gender who have reached a minimum age of thirty (30) years within the relevant calendar year.*

*The minimum number of participants in the category is 5 riders. If the minimum number is not met, the category for the given race will be cancelled and the riders in the Masters Women category will start in the Elite Women category.*

*The category is closed from a manufacturer perspective, the only accepted board specifications are JetSurf Race DFI 2021 and newer JetSurf DFI models. Further specifications can be found in sections 7.5 and 8. of the rulebook.*

**301.06 - JUNIORS BOYS**

*The Juniors Boys category is open to riders of male biological gender who are between eight (8) and fourteen (14) years within the relevant calendar year.*

*The category is closed from a manufacturer perspective, the only accepted board specifications are JetSurf Race DFI 2021 and newer JetSurf DFI models. Further specifications can be found in sections 7.5 and 8. of the rulebook.*

**301.07 - JUNIORS GIRLS**

*The Juniors Girls category is open to riders of female biological gender who are between eight (8) and fifteen (15) years within the relevant calendar year.*

*The category is closed from a manufacturer perspective, the only accepted board specifications are JetSurf Race DFI 2021 and newer JetSurf DFI models. Further specifications can be found in sections 7.5 and 8. of the rulebook.*

### 301.08 - ELECTRIC CHALLENGE

*The Electric Challenge category is open to riders of male and female biological gender who have reached a minimum age of sixteen (16) years within the relevant calendar year.*

*The minimum number of participants in the category is 5 riders. If the minimum number is not met, the category for the given race will be cancelled.*

*This category of fully electric powered motorized surfboards is open in terms of manufacturers' plurality. Further specifications can be found in sections 7.7 and 8. of the rulebook.*

### 301.09 - EXCEPTIONS

*If a rider does not meet the minimum age requirements for a given category and finishes the previous season in the top three, he/she may transfer to another category with the consent of the Motosurf Committee and solely upon the request of the rider or his/her legal representative.*

*In case a rider finishes the previous season in the Top 3 and achieves at least one podium result, the Motosurf Committee has the right to move the rider to another category before the start of the new season.*

*The Motosurf Committee reserves the right to change the category chosen by the rider when registering for the race and also has the option to cancel his/her registration for the race.*

*Boards that do not meet the category specifications may only be allowed to compete with the approval of the Motosurf Committee.*

## 302 - THE TRACK, GENERAL DESCRIPTION

*The Motosurf race track shall always be set up within the designated competition zone.*

### Track Composition:

*The track shall consist of:*

- 25 to 40 buoys,
- Balloons,
- Finish gate or finish buoys (checkerboard pattern).

*The track should include:*

- Left turns (sharp, open, or hairpin),
- Right turns (sharp, open, or hairpin),
- A Long Lap,
- A Split Section.

### Long Lap

- An alternate, longer section of the course in distance and/or time.
- ~~The passage time of the Long Lap shall be between 20% and 50% of the average lap time in the Stock Men Class.~~
- A set number of Long Laps may be executed during a session, only after passing the finish gate at the end of the first lap.
- A Long Lap may be taken only once per lap.
- ~~The Long Lap may serve as compensation for a missed buoy. Compensation must be made at the first possible opportunity; otherwise, the rider will be penalized with the designated Long Lap time.~~
- The Long Lap zone is marked by one or more clearly distinguishable buoys, the first of which must be easily identifiable.

**Split Section**

***A Split Section divides the course into two possible routes and may be used as a strategic overtaking point.***

**Split Sections may be:**

- a) Alternating split,***
- b) Parallel split,***
- c) Long Lap split.***

**Riding Direction**

***The riding direction may be clockwise or counter-clockwise. The direction is typically opposite to the previous race. If safety conditions do not permit the course to be set in the opposite direction, Race Direction may alter the direction.***

**Riders Eligibility**

***If a rider is unable to ride the track properly and poses a potential danger to themselves or others, that rider shall not be permitted to participate in the event.***

**302.01 - BUOYS**

The buoys are inflatable or made from rubber material in an oval shape. The buoys are anchored in such a way that the binding material does not stretch into the racing area and does not cause any danger and does not represent an obstacle heading to the race line. The colour of buoy or distinguishing sleeve determines the passing direction around the buoy. Every buoy set contains the buoy itself and a sleeve with a particular colour which distinguishes the passing direction.

**302.02 - BUOY TECHNICAL SPECIFICATION**

The technical specification of the buoy shall respect first and foremost the safety of the riders. The buoy is made from inflatable material with an inside chamber for ballast water to keep the stability and air to help maintain the shape of the buoy. The buoy is designed with pad eyes on the bottom in order to stay on the water surface without moving. See picture nr. 1 for official buoy construction.

**302.03 - BUOYS SLEEVES COLOURS**

- a) **Yellow,**

The yellow buoy is designed to mark the track so that the rider makes a right-hand turn and pass on the left side of the yellow buoy. Correctly passed buoy marked with yellow sleeve means the buoy is passed from the left side. If the buoy is passed from the right side or is hit by the center of the board, such action is reviewed as missed buoy.



Correct passing of the yellow buoy

b) **Red,**

The red buoy is designed to mark the track so that the rider makes a left-hand turn and pass on the right side of the red buoy. Correctly passed buoy marked with yellow sleeve means the buoy is passed from the right side. If the buoy is passed from the left side or is hit by the center of the board, such action is reviewed as missed buoy.



Correct passing of the red buoy

### 302.04 - BALLOONS AND THEIR CORRECT PASSINGS

a) **Orange balloons**

The orange balloons are used to indicate the beginning of a track separation (used in pairs). After passing through the balloons the rider may choose one of two tracks to follow up to the merging point (it is again marked by a pair of orange balloons). The pair of orange balloons are also used for marking the point of return from the long lap zone.

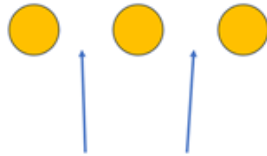

Correct passing of the three balloons section (Split section exit)



Correct passing of the two balloons section (split entry)

Not passing the orange balloons is understood as missing the buoys and will be penalized by a Long Lap run or a time penalty.

b) **Green balloons**

The Green balloons indicate the end of the track's start section leading to the race track. When two riders are coming back from two separated ways on the race course, there is no given or preferred way by any rider.

The balloons have to be passed from the correct side, any other passing of the balloons are classified as missed balloon with penalty equal to missed buoy.

## 303 – RACE TRACK SAFETY

### 303.01 - SAFE ENTRANCE TO THE RACE TRACK

***Riders may enter the race track only through the designated entrance area. The exact location and direction of entry will be announced before the first session. All rider entry onto the track shall be coordinated by the Pit Area Coordinator.***

### 303.02 - SAFE RIDE

Safe ride is the only way to achieve good sports performance and to minimize injuries during races. Therefore, all riders shall comply with the safety principles. It is not acceptable for the riders to perform dangerous manoeuvres (deliberately closing the course to the buoy despite the fact that is apparent from their ride that they will not be able to turn appropriately), it is not acceptable to roughly push the riders riding next to them, to intentionally drive into the opponent's surfboard etc. It is strictly forbidden to return to the buoy in case it has been run from a wrong side or was missed. Any turn into opposite direction of the race course is considered as dangerous riding and will be penalized. In the case of the incidents not listed above the incident will always be assessed with the help of the camera and the track observers.

Dangerous riding can be penalized financially, by changing of the order, taking away points, or disqualification from the race, based on its seriousness. Decision of such matters on such matters are final and under absolute right of the O.O.D.

### 303.03 - SAFE EXIT FROM THE TRACK DURING THE RACE

***A safe exit from the race track is defined as leaving the course without crossing the active racing line. The rider must continue in the direction of travel, outside the buoy line, and proceed toward the designated exit area.***

***A rider shall never change direction or cross the race track when exiting. Any such action is considered a serious breach of safety and will result in a penalty.***

### 303.04 - SAFE EXIT FROM THE TRACK AFTER THE RACE

***A safe exit from the race track is defined as leaving the course without crossing the active racing line.***

***After passing through the finish gate, the rider must:***

- a) if the exit point to the race track is before the finish gate: continue in the direction of travel, outside the buoy line, toward the exit area;***
- b) if the exit point is after the finish gate: take the shortest safe route directly to the exit area.***

***A rider shall never block the finish gate, turn inside it, or pass through it in the opposite direction. Such actions are considered a serious breach of safety and will result in penalty.***

### 303.05 - SIGNALS INDICATING A POTENTIAL INJURY DURING A SESSION

*If a serious situation occurs which may endanger the health of participants or require immediate medical attention, the following procedures apply:*

- a) *If the injured rider can signal, he/she shall raise one hand from the water and lift the nose of the board while lying on it.*
- b) *If the injured rider is not capable of signaling, the rider who notices the incident shall immediately raise one hand and ride towards the injured rider.*
- c) *Other riders who see the injured rider, or the raised hand of a rider providing assistance, shall raise their hand and leave the race track safely.*
- d) *If the Track Referee notices an injured rider, he/she shall signal to stop the race by waving a red flag above the head. Riders must exit the track safely following the exit rules. A red flag indicates that rescue and emergency services are immediately activated.*

*Any injured rider must undergo medical examination.*

### 303.06 - SIGNALS INDICATING A POTENTIAL TECHNICAL ISSUE

In the event of such a technical problem that requires immediate attention for the rider and the interruption of the race, the rider raises his/her hand as if signaling Injury and rotates his/her hand above his/her head.

In case of an injury or serious technical issue, the rider needs to visit a doctor for health condition check-up or a mechanic for a technical conditions check of the board. If the session interruption was not eligible, the rider will be penalized as unsportsmanlike behaviour as in Art. 16.6.5.

### 303.07 - DECLARING RIDER'S FITNESS TO AN UPCOMING SESSION

In case a rider sustained an injury and was taken for medical examination, fitness declaration about continuing in the event's programme is based only on the doctor's decision. Such decision shall be delivered to the O.O.D. at least 30 minutes before the session. Later declaration will not be considered.

## 304 - FINISH GATE

The gate consists of inflatable structures, or a pair of specially marked buoys (chequered). The gate is used for the purpose of the qualification, heats and finals. ***A lap is considered completed when a rider passes through the gate.*** In case of heats and the Final the passing through the gate is considered as a finished lap. In the last lap the rider's passage is waved by the chequered flag drop. Finish Gate is the point on the track where timekeeping starts/stops and where sessions are finished. If a technical problem arises during the last lap before the finish within two buoys before the finish gate, then the rider may swim with the board to the finish. Otherwise, the rider shall clear the way (for safety reasons) and wait until the end of the ride. Jumping is forbidden in an area of 10 meters around the gate. This action would lead to a Penalty 1. In case more motorized surfboards will cross the finish line, the better position counts for the front edge of the craft closer to the finish line.

## 305 - STARTING BLOCK

This is a device designed for the starting procedure from the shore. The starting block is designed to hold the board in the starting position. The rider puts the board on the starting block and gets ready for further flag or light signal. It is up to the rider on what side of the board the rider stands. The officially recommended starting block can be seen in Picture 3 in Appendix 1.

## 306 - TRACK LENGTH – MOTOSURF WORLD CHAMPIONSHIP ONLY

The track for the MotoSurf World Championship event should not be shorter than 40 seconds per lap. The reference lap time is taken from 1<sup>st</sup> fastest in the Stock **Men** Category.

## 307 - LAP CHART

### **Elite Men**

Heats: 8 laps, **3** long laps

F1: **10** laps, **3** long laps

### **Stock Men / Masters Men**

Heats: **7** laps, **3** long laps

F1: **10** laps, **3** long laps

### **Elite Women / Masters Women**

Heats: **7** laps, **3** long laps

F1: **9** laps, **3** long laps

### **Juniors Boys / Juniors Girls**

Heats: **5** laps, **2** long laps

F1: 6 laps, **2** long laps

### **Electric Challenge**

Heats: 5 laps, 2 long laps

F1: 6 laps, 2 long laps

***A rider may only commence a Long Lap run after having passed the Finish Gate at least once during the race.***

***The Race Direction (O.O.D. and/or Sport Director) reserves the right, for reasons of safety, course configuration, environmental conditions, or sporting fairness, to modify, suspend, reduce, or increase the number of Long Lap runs and/or Long Lap buoys, either prior to the start of the race event or during the race event, provided that such decision is communicated to all affected riders at the rider's briefing and/or via race bulletin.***

## 308 - TRACK PROFILE CHANGES DURING A SESSION

### 308.01 - BUOY DISAPPEARANCE FROM THE WATER SURFACE

If the buoy suffers such damage that it disappears from the surface (it has sunk).

### 308.02 - BUOY IS LAID ON THE WATER SURFACE

If there is movement of the balancing weights or the balancing material in the buoy moves in such a way that the buoy is horizontally on the surface of the water for a period longer than the duration of one lap.

**308.03 - DISTINGUISHING SLEEVE IS DROPPED FROM THE BUOY**

The distinguishing sleeve is removed from the buoy or damaged.

**308.04 - BUOY CHANGES ITS POSITION DURING THE SESSION**

*A buoy is considered to have changed its position if it moves on the track in a way that significantly affects the next rider or prevents safe passage through the track.*

*In practice, this occurs when:*

- *An individual buoy moves by more than one third of its distance from other buoys.*
- *A buoy shifts in such a way that safe passage becomes dangerous.*

**308.05 - FINISH GATE CHANGES ITS POSITION DURING THE SESSION**

Finish gate or finish buoys create an imaginary line between the final buoys and determine the area of the qualification or race finish. If this line is rotated by more than forty-five degrees from its default position, it is considered as a change of the rotation angle of the finish gate.

**308.06 - IMPROPER RACE TRACK**

Improper track is a track that does not allow the rider to pass through it safely or clearly without endangering another rider's ride. If a buoy disappears from the water surface, it can be considered as an improper track. If the race or heat has been completed from at least 3/4 (conclusive) of its total amount of laps, then the results from the last known passing through the finish are counted, otherwise the race or the heat is repeated. In case of qualification, the qualification lap is repeated. It is not possible to consider a track improper if the buoy is lying and at least 1/4 of it remains on the water surface. If at least 1/4 of the lying buoy does not remain on the water, the buoy is considered as lost and the previous provisions apply. It is not possible to consider a track improper if the buoy loses the distinguishing sleeve after the first lap. The track can be declared improper if three successive buoys are without the distinguishing sleeve. If the race or heat has been completed from at least 3/4 (conclusive) of its total amount of laps, then the results from the last known passing through the finish are counted, otherwise the race or the heat is repeated. In case of qualification, the qualification lap is repeated.

If the buoys are not clearly distinguishable, the session is interrupted until the situation is fixed. Only the finished heats or finals will be counted in the overall scoring of the championship. The track can be considered as improper if there is such movement of the buoy or buoys that are dangerous to pass for other riders in the opposite direction or in the direction of the rider. If the race or heat is finished from at least of 1/2 (conclusive) of its total amount of laps, then the results from the last valid passing through the finish gate are valid, otherwise the race or the heat is repeated. In case of qualification, the qualification lap is repeated.

The track can be considered as improper if the finish gate rotates in such a way that passing through it is dangerous to the other riders especially when the finish gate has been rotated. If the race or the heat is completed from at least 1/2(conclusive) of its total amount of laps, then the results from the last known passing through the finish gate are counted, otherwise the race or heat is repeated. In case of qualification, the qualification lap is repeated.

### **308.07 - IMPROPER RACE COURSE CLAIM**

The O.O.D. has the right to declare the track improper and interrupt a session by waving a red flag.

The rider has the right to declare the track improper if the buoy has sunk, if the distinguishing sleeve of three successive buoys were removed, if the buoy has been laid down and not at least 1/4 of the buoy is visible above the water or if there has been a dangerous shift of the buoy. The rider signals in the finish area to the O.O.D. that the track is improper by repeatedly and visibly moving his/her free hand up and down below the level of the waist while reducing their speed. The Race Direction then immediately stops the heat or the race. Each stop is individually assessed. It is up to Race Direction's consideration to stop the session.

## **309 - FLAG SIGNALS**

### **309.01 - FLAG SIGNALS DEFINITION, MEANING, ACTION**

#### **309.01.01 - GREEN**

The green flag is used for starting purposes. The Flag Marshal and Pits Area Coordinator use it for signaling "ready"- flag (flagpole) is horizontal to the surface of the water, stretched out sideways, the "steady"- the flag is placed vertically, "go" downward movement of the flag.

Waving of the green flag signals to the riders that the track is clear of obstacles, and the riders may continue. The green flag signals to the Start Marshal that the riders are ready and the start procedure can be started.

This flag is also used to open the entrance into water. It shall always be used if the entrance is closed using the red flag.

#### **309.01.02 - RED**

Immediate interruption of a session. The Flag Marshal and Rescuers waving the red flag signal an immediate interruption of the session, the riders head off and safely exit the track to the shore. This flag is also used for the closing of the entrance into the water. If the flag is raised up, there is a ban on entering the water.

#### **309.01.03 - BLACK**

The black flag indicates an immediate cancellation of the particular rider's ride. The rider shall immediately leave the race track via the safe path and head towards the shore.

#### **309.01.04 - CHEQUERED**

Waving of the chequered flag announces the end of a session in case the leader of the current session is lapping a rider in front, leading rider has a preference in flag signalization. Chequered flag is ready to wave the leading rider, the lapped rider does not need to be signalized with last lap flag signalization.

#### **309.01.05 - WHITE**

White flag signalizes the last lap of the heat or the race.

## 310 - LAPS SIGNALS

For better orientation in the race distance, the current lap is signalled to the riders. Signals are given based on the leading rider position. Flag marshal signals the number of laps in descending order. In case a lapping rider goes too close to a lapped rider, the signal is valid for the rider in the more forward position.

## 311 - PROPER RIDE DEFINITION

### 311.01 - PROPER POSTURE

Motorized surfboard is designed for riding in a stand up or squat position. It is not allowed to ride lying down or in kneeling position.

***After start from a shore, the competitors must stand up before the first turn buoy. In the case of a rider falls in water, the rider must stand up within the next two buoys.***

### 311.02 - PROPER DIRECTION

***The official track riding direction is announced during the first Riders' briefing prior to the start of the race weekend and remains unchanged for all sessions throughout the event. Riders must always follow this direction.***

***Riding in the opposite direction, turning around on the track, or attempting to re-pass a buoy after missing it is strictly prohibited. Any such action constitutes a serious breach of safety regulations and may result in disqualification from the respective session.***

## 312 - STARTING PROCEDURE

There are two methods to initiate or restart a race:

- Flying start, also known as a rolling start
- Start from the shore, also known as a standing start

### 312.01 - FLYING (ROLLING) START

A flying (rolling) start is one of the methods to initiate or restart a race. In this type of start, racers are arranged in the starting area in a predetermined formation and proceed to the start line, following the start signal from the start marshal:

- The leading rider is responsible for maintaining the formation before and when the green flag is raised. If the starting procedure is repeated due to the green flag not being raised, the leading rider remains responsible for correct formation.
- The leading rider must not ride too slowly (in displacement mode of cruising).
- The leading rider must not ride too quickly to ensure the formation can be maintained by the other riders.
- The leading rider must maintain a consistent speed and riding style to ensure a smooth starting procedure for the others. If the leading rider repeatedly changes speed or riding style, they will be moved to the last position in the group after the second occurrence.
- If the start procedure is repeated, the leading rider must turn the entire group at a safe distance from the start marshal, respecting the space limits for turning the group. Riders with surfboards must line up for the flying (rolling) start in the following order:
- The leading rider initiates the formation, and the other riders follow.
- The tip (bow) of the next rider's surfboard must follow the end (stern) of the previous rider's surfboard without overlapping.

- The vertical distance (along the racetrack direction) between two riders must not exceed the length of two boards.
  - The horizontal distance between riders must be at least an arm's length.
  - The second row (rider number 7) must start at least half a board length behind rider number 6 and must be positioned between rider number 5 and alignment with rider number 6. If rider number 7 follows in line with riders number 1-6, they will be considered as part of the first row and penalized with a Jump Start penalty.
  - If a rider intentionally slows down during the starting procedure or maintains a distance longer than two board lengths from the previous rider, they will be penalized with the last start position in the next starting procedure. Other riders maintaining proper distances will not be penalized with a Jump Start penalty.
- The start marshal is typically positioned on the opposite side of the formation from the leading rider unless otherwise decided by the Officer of the Day (O.O.D.).

The formation type is announced by the O.O.D. during the briefing before race heats and can be one of the following:

- V shape (position of the leading rider is always on the inside of the first turn. If the first turn is to the right, the formation will be mirrored horizontally)



- Cascaded one line (position of the leading rider is always on the inside of the first turn. If the first turn is to the right, the formation will be mirrored horizontally)



The flying start formation A depends on the racecourse lap direction and the direction of the first turn.

## **312.02 - START FROM THE SHORE**

### **312.02.01 - STARTING BLOCK**

Starting block is a device designed for starting procedure from the shore. The starting block is designed to hold the board in the starting position. The rider puts the board on the starting block and gets ready for further flag or light signalizations. It is up to the rider on what side of the board the rider stands. The officially recommended starting block can be seen in Picture 3 in Appendix 1.

### **312.02.02 - STARTING BLOCKS LINING UP**

For Heats 1-3, riders are taking positions according to qualifying results in descending order.. For the finals, riders are taking positions according to results of the sum of the Heats 1-4 in descending order. The rider higher in the standings selects first and may start from any block, the second rider selects second until all gates are occupied.

### **312.02.03 - STARTING PROCEDURE**

The start procedure begins with the riders lining up next to the starting blocks. Riders choose starting positions as in Art. 312.02.03. The Pits Area Coordinator checks whether all riders are ready and then signals to the O.O.D. that the riders are ready by raising a green flag. Before the start of a particular session, riders all categories conduct a warmup start and ride one lap on a designated lap. Such lap is announced on the first briefing by O.O.D. Helpers can help to bring the boards only to the starting procedures. However, when the starting procedure begins, every rider has to stand on his/her own.

### **312.02.04 - SIGNALS GIVEN DURING THE STARTING PROCEDURE**

Pits Area Coordinator checks to make sure all the riders are ready for the start procedure.

Pits Area Coordinator raises the flag and blows a whistle. A horizontal flag signals for the riders to get ready) Riders then shall start their engines.

In case any rider faces an issue, it is necessary to signal such issue by raising a hand. Pits Area Coordinator then signals the issue to Start Marshal to interrupt the start procedure. Pits Area Coordinator waits 2 minutes for the rider to solve the issue. If the issue persists, the start marshal removes the green flag giving the rider 2 more minutes to solve their technical issue. In case the problem persists even after this period of time, the green flag is raised and the starting procedure continues.

In case the rider has possibility to change the board, he/she can use another board which is has gone through the technical control and is compliant with technical requirements for the category the rider who faced the issues is racing.

In case all riders are ready to start, Pits Area Coordinator raises the green flag which gives a signal to Start Marshal.

### **312.02.05 - START MARSHAL RISES THE FLAG – PAY ATTENTION**

Based on the Start Marshal decision, a downward rapid movement with the flag starts the session.

While the flag is raised, the start procedure cannot be interrupted. If the procedure was interrupted once and another issue occurs to another rider, the start procedure is not interrupted for the second time.

### **312.02.06 - STARTING LIGHTS START**

The starting light start is executed the same way as the flag start, except that the green flag start is replaced by a starting light with three lights. The Guards Officer checks whether all riders are ready and signals to the O.O.D. that they are ready by raising a green flag. Then a whistle and a flashing light signals to the riders for them to start their engines. The competitors are responsible for starting up the motorized surfboard.

If a rider has a technical problem, he/she indicates it to the Race Direction by raising a hand. The Guards Officer then uses a red flag to signal a delay to the Race Direction. The rider shall start up within two (2) minutes. If he/she manages to start up the board within the time limit, the Guards Officer signals with a green flag. If he/she fails to repair the motorized surfboard, the O.O.D. resumes the starting procedure.

Subsequently, the lights one by one come on from left to right. The moment the lights go down the start occurs, and the session is under way. When the lights are on, the start procedure is not interrupted. If the procedure was interrupted once and another issue occurs to another rider, the start procedure is not interrupted for a second time.

Starting lights are a device serving for objective and save race start from shore or from pontoon. The light has horizontal position with three lights in a line. The light may be placed on a construction, shore or a jet ski. The lights are turned on from left to right within one second from the previous light. Riders can start only after all three lights are shut down. Difference between turning all three lights on and off is random and may be anywhere from 0.5 – 3 seconds.

### **313 - ANNOUNCEMENT OF THE STARTING METHOD**

*The starting method (flying start or starting blocks start) is determined by the O.O.D. and announced during the riders briefing. The decision takes into account the natural conditions of the race location, with the highest priority given to rider safety. The final decision is always made by the O.O.D., prioritizing safety above all.*

### **314 - THE PRACTICE START**

The practice start is used to teach the starting procedure that will be used during the ongoing races. The practice start is always performed once. Practice start is conducted before the Heat 1. After performing the start, the leading rider raises his/her hand to signal to all competitors to "slow down and follow me".

### **315 - RESTART**

*In the event of a race interruption, the O.O.D. may order a restart. Riders shall resume from the same starting positions as at the beginning of the interrupted race.*

### **316 - ACKNOWLEDGEMENT AFTER LAST VALID LAP BEFORE RESTART**

In case of finishing 4 laps in a heat or 6 laps in the race, the session is not restarted but the last completed lap result is valid.

## 317 - RACE PENALTIES

The O.O.D may impose any one of the penalties below on any driver involved in an Incident:

1. Time penalty
  - a. 100% of announced lap time
  - b. 60% of announced lap time
  - c. Time of announced long lap time
  - d. 15 seconds time penalty**
  - e. 10 seconds time penalty
  - f. 5 seconds time penalty
2. Position drop (the number of positions depends on the decision of the O.O.D)
3. Disqualification
  - a. From the session (in such case, rider won't be awarded points from the session)
  - b. From the race day (in such case, rider won't be awarded points from the whole racing day)
  - c. From the whole race weekend (in such case, rider won't be awarded points from the whole racing weekend)
4. Financial penalty (the amount of the financial penalty depends on the decision of the O.O.D)

The penalties will be imposed by the O.O.D based on his decision on an incident. The O.O.D has a right do give a different type of penalty than stated in sections below.

### 317.01 - LONG LAP

- ***Time penalty for not passing a Long Laps will be announced by O.O.D. before the heats.***
- ***Time penalty will be awarded for each rule breach.***
- ***It is not possible to enter the Long Lap twice in one lap. If a rider enters the Long Lap twice in one lap, it will only be counted as 1 long lap.***
- ***Riders are not allowed to go to Long Lap in the first lap of the session. Rider is allowed to go to the Long Lap only after passing through the finish gate at least once.***
- ***When a rider is entering the Long Lap, the rider shall indicate such action by raising his/her arm.***

### 317.02 - JUMP START PENALTY

***The penalty for a jump start is 100% of lap time earlier announced by O.O.D.***

***Jump starts will be judged based on a camera recording.***

***Actions will be judged by the O.O.D.***

### 317.03 - MISSED BUOY

- ***15 second time penalty for each buoy missed in the particular session.***
- ***If by missing the buoy the rider gains a significant advantage, he will be awarded with a time penalty based on the decision of the O.O.D.***

#### **317.04 - FORCED MISSED BUOY (DUE TO NECESSITY OF PASSING AN OBSTACLE IN THE WATER)**

*If a rider misses a buoy due to an obstacle in the water, safety reasons, or being forced off the track by another rider, the standard penalty for a missed buoy may not apply. The obstacle must be physically present and obstructing the buoy line at the exact time when the rider is approaching or attempting to pass the buoy. A rider may not decide in advance to skip a buoy because of an obstacle observed earlier.*

*In all cases, the rider must rejoin the course without gaining any advantage in time or position. If an advantage is obtained, a time penalty will be applied.*

*All such incidents will be reviewed by Race Direction using official camera footage, and the determination of whether the buoy was missed under forced circumstances rests with the O.O.D.*

#### **317.05 - MISSING MORE BUOYS**

*If a rider misses more than 3 buoys in the same lap, then the rider is disqualified from the session.*

*This rule does not apply if the rider falls in the water, he/she is allowed to miss 1 buoy (or 2 buoys in the slalom section) and these buoy(s) are not taken as missed buoys.*

#### **317.06 - LATE STAND UP ON THE SURFBOARD**

*During the start from the starting blocks the rider shall stand up on the motorized surfboard within the first turning buoy.*

*After falling into the water, the rider is obligated to stand up back on his/her surfboard within two buoys.*

*If the rider fails to meet this rule, he/she will be penalised by a time penalty of 10 seconds.*

#### **317.07 - LATE ARRIVAL OR ABSENCE ON THE BRIEFING**

*All briefings are mandatory for all the riders that are still racing during the particular weekend (not mandatory for riders that abandoned the race).*

*In case of failing to attend the briefing:*

- *1 absence or late arrival = financial penalty of 100€*
- *2 or more absence = disqualification from the event*

*If there is a serious reason for not attending the briefing, the penalty won't be applied. In this case, the rider has to contact the race direction before the briefing.*

#### **317.08 - TECHNICAL INFRINGEMENTS**

*If a rider commits an infringement of the technical rules described in Articles 7 and 8, they may be penalised by disqualification from the session, the entire race day, or the whole race weekend.*

*The severity of the penalty will be assessed by the Technical Commissioner and the O.O.D.*

### 317.09 - IRRESPONSIBLE RIDING

Irresponsible riding is understood as riding which is considered dangerous and may lead to injury of the rider herself/himself or injury of others or intends any unsportsmanlike behaviour. The types of irresponsible riding are as following:

- *Knowingly gaining an advantage*
- *Dangerous overtaking manoeuvre*
- *Causing a collision*
- *Forcing another rider of the track*
- *Riding in the wrong direction than stated by the race direction*
- *Disobeying orders from the race direction*

*Such actions will be reviewed by the judges or the camera footage. Penalty is imposed by the decision of the O.O.D.*

### 317.10 - PENALTIES FOR UNSPORTSMANLIKE CONDUCT

*In case of unsportsmanlike behaviour, the O.O.D. has the right to impose any of the card penalties described in 16.6.5.*

## 318 - RACE FORMAT

### 318.01 - FREE PRACTICE SESSION (FP)

*For practice sessions, riders are divided into groups according to Championship standings, if available. For the first race of the season, standings from the previous season may be used. Each group shall have its own practice schedule.*

*A rider who misses his/her assigned practice may participate in another group's session only with prior confirmation from Race Direction.*

*Free Practice begins with the green flag signal. At this signal, riders may enter the race track. Entry from the starting block is strictly prohibited, and no rider may gain an advantage by performing additional practice starts. Any rider who performs a practice start from the starting block during Free Practice will be penalized.*

*The session ends with the display of the checkered flag.*

### 318.02 - WARM UP SESSION (WUP)

Warm up session is held before the heats to warm up the riders, check out the racecourse and warm up the motorized surfboards. Riders are sorted into groups based on the same principle as for the Free Practice. It is forbidden to enter the race track from the starting block and getting an advantage of more practice starts. In case a rider makes a practice start from the starting block in the Free practice session, such rider will be penalized for Penalty according to Art.17.

**318.03 - QUALIFYING SESSION (QP)****318.03.01 - QUALIFYING DEFINITION**

*Qualification is a mandatory stage of the race. Each rider shall complete two timed laps in the announced riding direction.*

*The fastest recorded lap time determines the pole position. The rider with pole position shall lead the group in case of a flying start or select the first starting position in case of a start from the shore.*

*In the event of identical lap times, the second-best lap time shall be used to determine the order. If the times remain identical, the affected riders shall draw lots under the supervision of Race Direction.*

*Riders who fail to record a qualifying lap time shall start from the back of the grid.*

**318.03.02 - QUALIFICATION PAIRS (TWO RIDERS)**

*Pairs are determined according to Championship standings, if available, with riders of closest points forming pairs in top-to-bottom order. In the case of an odd number of riders, the top two riders shall start together, and the last rider may qualify alone.*

*The two riders enter the track simultaneously under the direction of the Track Marshal.*

*The first rider positions in the designated waiting area and starts upon the green flag signal. The rider shall not pass the start gate before the signal, nor cause intentional delays. Any delay will be penalized. Timekeeping begins when the rider passes through the start gate and ends after crossing it again. If the rider falls or chooses not to resume the lap, he/she shall raise one hand. A green flag will then signal authorization to attempt the second qualification lap.*

*The second rider positions in the designated area and starts upon the green flag signal, approximately when the first rider has completed 50% of the lap.*

*Each pass through the gate is signaled by a green flag (continue) or a checkered flag (end of run). After finishing, riders shall exit the track immediately via the designated exit point to clear the course for the next pair.*

*Each rider may complete up to two qualification laps. In the event of obstruction caused by another rider's fall or by an obstacle on the racing line, one additional lap may be granted, up to a maximum of three laps. Any further exception may be granted only by the O.O.D.*

**318.03.03 - QUALIFICATION TRIO (THREE RIDERS)**

*Trios are determined according to Championship standings, if available, with riders of closest points forming groups of three in top-to-bottom order. If the number of riders does not allow forming full trios, the last session may consist of two riders or a single rider qualifying alone.*

*The three riders enter the track simultaneously under the direction of the Track Marshal.*

*The first rider positions in the designated waiting area and starts upon the green flag signal. The rider shall not pass the start gate before the signal, nor cause intentional delays. Timekeeping begins when the rider passes through the start gate and ends after crossing it again. If the rider falls or chooses not to resume the lap, he/she shall raise one hand. A green flag will then authorize the start of the next lap.*

*The second rider positions in the designated area and starts upon the green flag signal, approximately when the first rider has completed 33% of the lap.*

*The third rider positions in the designated area and starts upon the green flag signal, approximately when the second rider has completed 33% of the lap.*

*Each pass through the gate is signaled by a green flag (continue) or a checkered flag (end of run). After finishing, riders shall exit the track immediately via the designated exit point to clear the course for the next group.*

*Each rider may complete up to two qualification laps. In the event of obstruction caused by another rider's fall or by an obstacle on the racing line, one additional lap may be granted, up to a maximum of three laps. Any further exception may be granted only by the O.O.D.*

#### **318.04 - DIVISION OF RIDERS INTO GROUPS**

*Riders are divided into groups based on the total number of registered riders, as determined on the day of registration. No additional entries shall be accepted after registration is closed.*

*Groups are formed according to the official qualifying results. The qualifying winner shall lead Group A, the second-place rider shall lead Group B, and so on. The detailed logic of group assignment is specified in the next section of this Rulebook.*

#### **318.05 - HEAT 1, HEAT 2, HEAT 3, HEAT 4 (HT)**

All Heats have the same direction as the qualification. The heat consists of a number of laps described in section 307 of this rulebook. The heats are run according to the groups that were created after the riders' qualification. The leader (the best rider according to the qualification in the group) leads the starting procedure (in case of flying start). See chapter ride, flying start and off-shore start. If a rider misses the buoy, she/he shall conduct an extra Long Lap run in the current or following lap (it is not considered as an obligatory run). Riders execute the number of Long Laps in a heat as in Art. Lap Chart. However, it is only up to the rider in which lap he/she decides to do so. The rider is allowed to take the Long Lap(s) after having completed at least one lap.

The race ends by passing through the gate and taking the chequered flag, only riders who pass through the gate and take the chequered flag have the right to receive points according to their position in the particular session. If no flag is dropped for the rider then he/she is marked as a DNF (did not finish) and receives zero (0) for the particular session.

As soon as the first rider passes through the finish line and receives the flag drop, all the other riders receive the flag drop as well.

That means the riders who were overtaken by one lap will not be completing the missing laps and after the flag drop they will safely exit the track, see section "Safety", safe exit from the track after the race.

The full racing format consists of 4 four heats. Where 3 (three) best heats count into point scoring.

Table Division into Heats in case of 4 groups:

Heat 1					Heat 2					Heat 3					Heat 4				
Rider	A	B	C	D	Rider	A	B	C	D	Rider	A	B	C	D	Rider	A	B	C	D
1	A1 (1.)	B1 (2.)	C1 (3.)	D1 (4.)	1	A1 (1.)	B1 (2.)	C1 (3.)	D1 (4.)	1	A1 (1.)	B1 (2.)	C1 (3.)	D1 (4.)	1	A1 (1.)	B1 (2.)	C1 (3.)	D1 (4.)
2	A2 (5.)	B2 (6.)	C2 (7.)	D2 (8.)	2	D2 (8.)	A2 (5.)	B2 (6.)	C2 (7.)	2	C2 (7.)	D2 (8.)	A2 (5.)	B2 (6.)	2	B2 (6.)	C2 (7.)	D2 (8.)	A2 (5.)
3	A3 (9.)	B3 (10.)	C3 (11.)	D3 (12.)	3	C3 (11.)	D3 (12.)	A3 (9.)	B3 (10.)	3	B3 (10.)	C3 (11.)	D3 (12.)	A3 (9.)	3	D3 (12.)	A3 (9.)	B3 (10.)	C3 (11.)
4	A4 (13.)	B4 (14.)	C4 (15.)	D4 (16.)	4	B4 (14.)	C4 (15.)	D4 (16.)	A4 (13.)	4	D4 (16.)	A4 (13.)	B4 (14.)	C4 (15.)	4	C4 (15.)	D4 (16.)	A4 (13.)	B4 (14.)
5	A5 (17.)	B5 (18.)	C5 (19.)	D5 (20.)	5	A5 (17.)	B5 (18.)	C5 (19.)	D5 (20.)	5	A5 (17.)	B5 (18.)	C5 (19.)	D5 (20.)	5	A5 (17.)	B5 (18.)	C5 (19.)	D5 (20.)
6	A6 (21.)	B6 (22.)	C6 (23.)	D6 (24.)	6	D6 (24.)	A6 (21.)	B6 (22.)	C6 (23.)	6	C6 (23.)	D6 (24.)	A6 (21.)	B6 (22.)	6	B6 (22.)	C6 (23.)	D6 (24.)	A6 (21.)
7	A7 (25.)	B7 (26.)	C7 (27.)	D7 (28.)	7	C7 (27.)	D7 (28.)	A7 (25.)	B7 (26.)	7	B7 (26.)	C7 (27.)	D7 (28.)	A7 (25.)	7	D7 (28.)	A7 (25.)	B7 (26.)	C7 (27.)
8	A8 (29.)	B8 (30.)	C8 (31.)	D8 (32.)	8	B8 (30.)	C8 (31.)	D8 (32.)	A8 (29.)	8	D8 (32.)	A8 (29.)	B8 (30.)	C8 (31.)	8	C8 (31.)	D8 (32.)	A8 (29.)	B8 (30.)
9	A9 (33.)	B9 (34.)	C9 (35.)	D9 (36.)	9	A9 (33.)	B9 (34.)	C9 (35.)	D9 (36.)	9	A9 (33.)	B9 (34.)	C9 (35.)	D9 (36.)	9	A9 (33.)	B9 (34.)	C9 (35.)	D9 (36.)
10	A10 (37.)	B10 (38.)	C10 (39.)	D10 (40.)	10	D10 (40.)	A10 (37.)	B10 (38.)	C10 (39.)	10	C10 (39.)	D10 (40.)	A10 (37.)	B10 (38.)	10	B10 (38.)	C10 (39.)	D10 (40.)	A10 (37.)
11	A11 (41.)	B11 (42.)	C11 (43.)	D11 (44.)	11	C11 (43.)	D11 (44.)	A11 (41.)	B11 (42.)	11	B11 (42.)	C11 (43.)	D11 (44.)	A11 (41.)	11	D11 (44.)	A11 (41.)	B11 (42.)	C11 (43.)
12	A12 (45.)	B12 (46.)	C12 (47.)	D12 (48.)	12	B12 (46.)	C12 (47.)	D12 (48.)	A12 (45.)	12	D12 (48.)	A12 (45.)	B12 (46.)	C12 (47.)	12	C12 (47.)	D12 (48.)	A12 (45.)	B12 (46.)

Table Division into Heats in case of 3 groups:

Heat 1				Heat 2				Heat 3				Heat 4			
Rider	A	B	C	Rider	A	B	C	Rider	A	B	C	Rider	A	B	C
1	A1 (1.)	B1 (2.)	C1 (3.)	1	A1 (1.)	B1 (2.)	C1 (3.)	1	A1 (1.)	B1 (2.)	C1 (3.)	1	A1 (1.)	B1 (2.)	C1 (3.)
2	A2 (4.)	B2 (5.)	C2 (6.)	2	C2 (6.)	A2 (4.)	B2 (5.)	2	B2 (5.)	C2 (6.)	A2 (4.)	2	C2 (6.)	A2 (4.)	B2 (5.)
3	A3 (7.)	B3 (8.)	C3 (9.)	3	B3 (8.)	C3 (9.)	A3 (7.)	3	C3 (9.)	A3 (7.)	B3 (8.)	3	C3 (9.)	A3 (7.)	B3 (8.)
4	A4 (10.)	B4 (11.)	C4 (12.)	4	A4 (10.)	B4 (11.)	C4 (12.)	4	A4 (10.)	B4 (11.)	C4 (12.)	4	B4 (11.)	C4 (12.)	A4 (10.)
5	A5 (13.)	B5 (14.)	C5 (15.)	5	C5 (15.)	A5 (13.)	B5 (14.)	5	B5 (14.)	C5 (15.)	A5 (13.)	5	B5 (14.)	C5 (15.)	A5 (13.)
6	A6 (16.)	B6 (17.)	C6 (18.)	6	B6 (17.)	C6 (18.)	A6 (16.)	6	C6 (18.)	A6 (16.)	B6 (17.)	6	A6 (16.)	B6 (17.)	C6 (18.)
7	A7 (19.)	B7 (20.)	C7 (21.)	7	A7 (19.)	B7 (20.)	C7 (21.)	7	A7 (19.)	B7 (20.)	C7 (21.)	7	A7 (19.)	B7 (20.)	C7 (21.)
8	A8 (22.)	B8 (23.)	C8 (24.)	8	C8 (24.)	A8 (22.)	B8 (23.)	8	B8 (23.)	C8 (24.)	A8 (22.)	8	C8 (24.)	A8 (22.)	B8 (23.)
9	A9 (25.)	B9 (26.)	C9 (27.)	9	B9 (26.)	C9 (27.)	A9 (25.)	9	C9 (27.)	A9 (25.)	B9 (26.)	9	C9 (27.)	A9 (25.)	B9 (26.)
10	A10 (28.)	B10 (29.)	C10 (30.)	10	A10 (28.)	B10 (29.)	C10 (30.)	10	A10 (28.)	B10 (29.)	C10 (30.)	10	B10 (29.)	C10 (30.)	A10 (28.)
11	A11 (31.)	B11 (32.)	C11 (33.)	11	C11 (33.)	A11 (31.)	B11 (32.)	11	B11 (32.)	C11 (33.)	A11 (31.)	11	B11 (32.)	C11 (33.)	A11 (31.)
12	A12 (34.)	B12 (35.)	C12 (36.)	12	B12 (35.)	C12 (36.)	A12 (34.)	12	C12 (36.)	A12 (34.)	B12 (35.)	12	A12 (34.)	B12 (35.)	C12 (36.)

Table Division into Heats in case of 2 groups:

Heat 1			Heat 2			Heat 3			Heat 4		
Rider	A	B	Rider	A	B	Rider	A	B	Rider	A	B
1	A1 (1.)	B1 (2.)	1	A1 (1.)	B1 (2.)	1	A1 (1.)	B1 (2.)	1	A1 (1.)	B1 (2.)
2	A2 (3.)	B2 (4.)	2	B2 (4.)	A2 (3.)	2	A2 (3.)	B2 (4.)	2	B2 (4.)	A2 (3.)
3	A3 (5.)	B3 (6.)	3	A3 (5.)	B3 (6.)	3	B3 (6.)	A3 (5.)	3	B3 (6.)	A3 (5.)
4	A4 (7.)	B4 (8.)	4	B4 (8.)	A4 (7.)	4	B4 (8.)	A4 (7.)	4	A4 (7.)	B4 (8.)
5	A5 (9.)	B5 (10.)	5	A5 (9.)	B5 (10.)	5	A5 (9.)	B5 (10.)	5	A5 (9.)	B5 (10.)
6	A6 (11.)	B6 (12.)	6	B6 (12.)	A6 (11.)	6	A6 (11.)	B6 (12.)	6	B6 (12.)	A6 (11.)
7	A7 (13.)	B7 (14.)	7	A7 (13.)	B7 (14.)	7	B7 (14.)	A7 (13.)	7	B7 (14.)	A7 (13.)
8	A8 (15.)	B8 (16.)	8	B8 (16.)	A8 (15.)	8	B8 (16.)	A8 (15.)	8	A8 (15.)	B8 (16.)
9	A9 (17.)	B9 (18.)	9	A9 (17.)	B9 (18.)	9	A9 (17.)	B9 (18.)	9	A9 (17.)	B9 (18.)
10	A10 (19.)	B10 (20.)	10	B10 (20.)	A10 (19.)	10	A10 (19.)	B10 (20.)	10	B10 (20.)	A10 (19.)
11	A11 (21.)	B11 (22.)	11	A11 (21.)	B11 (22.)	11	B11 (22.)	A11 (21.)	11	B11 (22.)	A11 (21.)
12	A12 (23.)	B12 (24.)	12	B12 (24.)	A12 (23.)	12	B12 (24.)	A12 (23.)	12	A12 (23.)	B12 (24.)

### 318.06 - THE FINAL F1

The Final F1 is in the same direction as the qualification. The winner of the heats is the leading rider who leads the starting procedure. See chapter ride, flying start and off-shore start. The Final consists of a number of laps described in section Lap Chart of this rulebook.

If the rider does not finish the race – passing through the Finish Gate in the last lap, such rider is marked as DNF (did not finish – status) and receives no points.

### 319 - SCORING

#### 319.01 - SCORING OF THE HEATS

**Heat results count toward both the Overall Racing Weekend classification and the Championship standings. For scoring purposes, the best three (3) heats out of four (4) are considered.**

**A rider disqualified in any heat shall receive zero (0) points for that heat; such a result cannot be omitted. All riders who finish a heat are awarded points, with the drop of the checkered flag recognized as the official finish. A rider who does not receive the checkered flag, regardless of position on the course, shall be classified as DNF and receive zero (0) points. If two riders are tied on points after applying the “best 3 of 4” rule, the higher qualifying result determines the ranking.**

**The ranking established under this rule defines the starting positions for the Final Session.**

1.	2.	3.	4.	5.	6.
18 pts	14 pts	11 pts	9 pts	8 pts	7 pts
7.	8.	9.	10.	11.	12.
6 pts	5 pts	4 pts	3 pts	2 pts	1 pt

Table 2 Heats scoring

#### 319.02 - THE SCORING OF THE FINAL

The Final F1 is awarded with as many points as in the heats. If a rider is not given the chequered flag and does not finish the race, the rider does not receive any points.

1.	2.	3.	4.	5.	6.
18 pts	14 pts	11 pts	9 pts	8 pts	7 pts
7.	8.	9.	10.	11.	12.
6 pts	5 pts	4 pts	3 pts	2 pts	1 pts

Table 1 Final scoring

#### 319.03 - RACE OVERALL SCORING

**The overall standings for the top twelve (12) riders are determined by their finishing positions in the Final session (F1). The standings for all remaining riders are determined by the ranking established in Section SCORING OF THE HEATS.**

### 319.04 - SEASON OVERALL STANDINGS

Points of all 3 (three) best heats out of 4 (four) and each particular Final (F1) will be counted. The overall points standings of the season consist of all races. All the races points scoring are valid to the Season's Overall Points standings. In the case that two riders are tied on points, the higher position in the last valid Race weekend determines the higher position in Season Overall points standings.

#### SUMMARY OF POINT SCORING

Podium Ceremony = Final (F1) standings

Overall Race Weekend points = sum of 3 (three) best heats out of (4) four + Final (F1)

Championship standings points = Overall Race Weekend Points.

### 320 - THE WINNER & PODIUM CEREMONY

*Each race concludes with a winners' podium ceremony. The top three riders in all categories shall be awarded on the podium.*

### 321 - EVENT SCHEDULE

*The entire event takes place over 4 days (1 day for technical controls and 3 race days) – most often from Thursday to Sunday. An example of the race weekend schedule is shown below, but it may change depending on the circumstances. The exact schedule will be published before the respective race.*

#### 321.01 - DAY 1 – TECHNICAL CONTROLS

Thursday					
START	END	DURATION	TIME GAP	EVENT	
10:00	11:00	1:00	0:00	ENGINES DRAWING (WOMEN & STOCK CLASS)	
10:00	11:00	1:00	0:00	TECHNICAL CONTROL - ELITE	
11:00	12:30	1:30	0:00	ENGINES ASSEMBLY (WOMEN & STOCK CLASS)	
11:00	13:00	2:00	0:00	TECHNICAL CONTROL - MASTERS	
13:00	14:00	1:00	0:00	LUNCH BREAK	
14:00	15:00	1:00	0:00	STOCK & WOMEN ENGINES TEST SESSION	
14:00	15:30	1:30	0:00	TECHNICAL CONTROL - JUNIORS	
15:30	17:00	1:30	0:00	TECHNICAL CONTROL - WOMEN	
17:00	18:30	1:30	0:00	TECHNICAL CONTROL - STOCK + STOCK R	
19:00	20:00	1:00	0:00	BRIEFING	

**321.02 - RACE DAY 1**

Friday					
START	END	DURATION	TIME GAP	EVENT	
9:00	9:10	0:10	0:00	FP1 - STOCK + STOCK R - GROUP A	
9:10	9:20	0:10	0:00	FP1 - STOCK + STOCK R - GROUP B	
9:20	9:30	0:10	0:00	FP1 - WOMEN - GROUP A	
9:30	9:40	0:10	0:00	FP1 - WOMEN - GROUP B	
9:40	9:50	0:10	0:00	FP1 - MASTERS - GROUP A	
9:50	10:00	0:10	0:00	FP1 - MASTERS - GROUP B	
10:00	10:10	0:10	0:00	FP1 - JUNIORS	
10:10	10:20	0:10	0:00	FP1 - ELITE - GROUP A	
10:20	10:35	0:15	0:00	TECHNICAL BREAK	
10:35	10:45	0:10	0:00	FP2 - STOCK + STOCK R - GROUP A	
10:45	10:55	0:10	0:00	FP2 - STOCK + STOCK R - GROUP B	
10:55	11:05	0:10	0:00	FP2 - WOMEN - GROUP A	
11:05	11:15	0:10	0:00	FP2 - WOMEN - GROUP B	
11:15	11:25	0:10	0:00	FP2 - MASTERS - GROUP A	
11:25	11:35	0:10	0:00	FP2 - MASTERS - GROUP B	
11:35	11:45	0:10	0:00	FP2 - JUNIORS	
11:45	11:55	0:10	0:10	FP2 - ELITE - GROUP A	
12:05	13:05	1:00	0:00	LUNCH BREAK	
13:05	13:50	0:45	0:00	QP - WOMEN	
13:50	14:10	0:20	0:00	QP - JUNIORS BOYS	
14:10	14:25	0:15	0:00	QP - JUNIORS GIRLS	
14:25	15:35	1:10	0:00	QP - MASTERS	
15:35	15:50	0:15	0:00	QP - ELITE	
15:50	16:55	1:05	0:50	QP - STOCK + STOCK R	
17:45	18:30	0:45	0:00	BRIEFING	

**321.03 - RACE DAY 2**

Saturday						
START (LT)	RT (C)	END (LT)	D (C)	DURATION	TIME GAP	EVENT
8:30		8:50		0:20	0:00	HEAT 1 - JUNIORS - BOYS (5 laps, 1 joker)
8:50		9:10		0:20	0:00	HEAT 1 - JUNIORS - GIRLS (5 laps, 1 joker)
9:10		9:30		0:20	0:00	HEAT 1 - WOMEN - GROUP A (7 laps, 2 jokers)
9:30		9:50		0:20	0:00	HEAT 1 - WOMEN - GROUP B (7 laps, 2 jokers)
9:50		10:10		0:20	0:00	HEAT 1 - MASTERS - GROUP A (6 laps, 2 jokers)
10:10		10:30		0:20	0:00	HEAT 1 - MASTERS - GROUP B (6 laps, 2 jokers)
10:30		10:50		0:20	0:00	HEAT 1 - ELITE (8 laps, 2 jokers)
10:50		11:10		0:20	0:00	HEAT 1 - STOCK + STOCK R - GROUP A (6 laps, 2 jokers)
11:10		11:30		0:20	0:00	HEAT 1 - STOCK + STOCK R - GROUP B (6 laps, 2 jokers)
11:30		11:45		0:15	0:00	HEAT 2 - JUNIORS - BOYS (5 laps, 1 joker)
11:45		12:00		0:15	0:00	HEAT 2 - JUNIORS - GIRLS (5 laps, 1 joker)
12:00		12:15		0:15	0:00	HEAT 2 - WOMEN - GROUP A (7 laps, 2 jokers)
12:15		12:30		0:15	0:00	HEAT 2 - WOMEN - GROUP B (7 laps, 2 jokers)
12:30		12:45		0:15	0:00	HEAT 2 - ELITE (8 laps, 2 jokers)
12:45		13:45		1:00	0:00	LUNCH BREAK
13:45		14:00		0:15	0:00	HEAT 2 - STOCK + STOCK R - GROUP A (6 laps, 2 jokers)
14:00		14:15		0:15	0:00	HEAT 2 - STOCK + STOCK R - GROUP B (6 laps, 2 jokers)
14:15		14:30		0:15	0:00	HEAT 2 - MASTERS - GROUP A (6 laps, 2 jokers)
14:30		14:45		0:15	0:00	HEAT 2 - MASTERS - GROUP B (6 laps, 2 jokers)
14:45		15:00		0:15	0:00	HEAT 3 - ELITE (8 laps, 2 jokers)
15:00		15:15		0:15	0:00	HEAT 3 - WOMEN - GROUP A (7 laps, 2 jokers)
15:15		15:30		0:15	0:00	HEAT 3 - WOMEN - GROUP B (7 laps, 2 jokers)
15:30		15:45		0:15	0:00	HEAT 3 - STOCK + STOCK R - GROUP A (6 laps, 2 jokers)
15:45		16:00		0:15	0:00	HEAT 3 - STOCK + STOCK R - GROUP B (6 laps, 2 jokers)
16:00		16:15		0:15	0:00	HEAT 2 - JUNIORS - BOYS (5 laps, 1 joker)
16:15		16:30		0:15	0:00	HEAT 2 - JUNIORS - GIRLS (5 laps, 1 joker)
16:30		16:45		0:15	0:00	HEAT 3 - MASTERS - GROUP A (6 laps, 2 jokers)
16:45		17:00		0:15	0:45	HEAT 3 - MASTERS - GROUP B (6 laps, 2 jokers)
17:45		18:30		0:45	0:00	BRIEFING

**321.04 - RACE DAY 3**

Sunday					
START	END	DURATION	TIME GAP	EVENT	
9:00	9:15	0:15	0:00	HEAT 4 - JUNIORS - BOYS (5 laps, 1 joker)	
9:15	9:30	0:15	0:00	HEAT 4 - JUNIORS - GIRLS (5 laps, 1 joker)	
9:30	9:45	0:15	0:00	HEAT 4 - ELITE (8 laps, 2 jokers)	
9:45	10:00	0:15	0:00	HEAT 4 - WOMEN - GROUP A (7 laps, 2 jokers)	
10:00	10:15	0:15	0:00	HEAT 4 - WOMEN - GROUP B (7 laps, 2 jokers)	
10:15	10:30	0:15	0:00	HEAT 4 - STOCK + STOCK R - GROUP A (6 laps, 2 jokers)	
10:30	10:45	0:15	0:00	HEAT 4 - STOCK + STOCK R - GROUP B (6 laps, 2 jokers)	
10:45	11:00	0:15	0:00	HEAT 4 - MASTERS - GROUP A (6 laps, 2 jokers)	
11:00	11:15	0:15	0:00	HEAT 4 - MASTERS - GROUP B (6 laps, 2 jokers)	
11:15	12:15	1:00	0:00	LUNCH BREAK	
12:15	12:30	0:15	0:05	F1 - JUNIORS GIRLS (6 laps, 2 joker)	
12:35	12:50	0:15	0:05	F1 - JUNIORS BOYS (6 laps, 2 joker)	
12:55	13:10	0:15	0:05	F1 - MASTERS (10 laps, 2 jokers )	
13:15	13:30	0:15	0:05	F1 - STOCK R (10 laps, 2 jokers )	
13:35	13:50	0:15	0:05	F1 - STOCK (10 laps, 2 jokers )	
13:55	14:10	0:15	0:05	F1 - WOMEN (9 laps, 2 jokers)	
14:15	14:30	0:15	1:30	F1 - ELITE - (12 laps, 2 jokers)	
16:00	17:00	1:00	0:00	FINAL CEREMONY	

**321.05 - EVENTS SCHEDULE UPDATES**

Race format may be updated based on the decision of the O.O.D. in order to react on current weather situation or other environmental aspects. The minimum requirements for validity of the event format as in Art. 22.1. of this rulebook.

**321.06 - MINIMUM REQUIREMENTS OF THE EVENT *SESSIONS***

*In order to claim the event valid and to award points to the championship, the event has to fulfil minimum these sessions:*

- a) *Minimum number of FP: 1*
- b) *Qualifying: 1 (obligatory part of the event)*
- c) *Minimum number of heats per class: 0*
- d) *Minimum number of Finals: 0*

*In case conditions do not allow completion of the heats and finals and if only the qualification is completed, the race winners will be declared based on the qualification results, but no championship points will be awarded.*

**321.07 - POINTS SCORING IN CASE OF UPDATED EVENT SCHEDULE**

If the event schedule changes the point scoring system will not change and will remain rigid. The points are assigned only for actually conducted sessions. Assigned points shall not be multiplied in order to cover the missing sessions.

In case the number of heats is cut to less than 3 (three), in such case, all the heats point scoring remains valid and none of the heats is dropped.

## 322 - NUMBER OF GROUPS

In the MotoSurf World Championships and Continental Cups, there are the track limits and the time schedule limits that are reflected in the maximum number of groups allowed to every event.

### 322.01 - MOTOSURF WORLD CHAMPIONSHIP

Maximum number of groups: 11

Groups per category

Elite **Men**: 1

Masters **Men**: 2

Stock **Men**: 2

Juniors Boys, Juniors Girls: 2

**Elite** Women: 2

**Masters Women: 1**

Electric Challenge: 1

Limit for the maximum attendance of the group is the qualifying, i.e. in case of 30 registered riders to Elite **Men** Category, the maximum number of groups is 1 which means only the top 12 will qualify to the Heats. The riders will qualify through the qualifying session, the top 12 riders proceed to the Heats. In case of the Stock **Men** Class, the maximum number of groups is 2 which means the 24 riders can qualify to the heats. The number of 24.

In case other classes do not reach their maximum allowed number of group, the Stock **Men** Class might be extended to 3 groups which means 36 riders in total qualify to the heats through the qualifying.

## **400 – JURISDICTION**

### **401 - DEFINITIONS**

*Jurisdiction applies to:*

*The UIM Aquabike, Circuit, MotoSurf, Offshore and Pleasure Navigation Rules.*

#### **401.01**

*No claim for damages arising from an infringement of any of the UIM rules or the advance program or any of the race instructions or race bulletins shall be adjudicated upon by any race committee or appeal authority, but shall be subject to the jurisdiction of the courts.*

*The crew of a racing Aquabike which acknowledges infringing a rule does not thereby admit liability for damages. The findings of fact, and the decision of the protest judge shall be relevant only to the purposes of the powerboat racing rules and shall not be referred to in any proceedings for damage without the written consent of all parties to the protest.*

### **402 - JUDICIAL BODIES**

#### **402.01 – THE PROTEST JUDGE**

##### **1. PROTEST JUDGE**

*A Protest Judge will hear the protests if so foreseen by the class rules. If not foreseen by the class rules, the UIM may appoint a Protest Judge for a particular event. The Protest Judge must be named in the Advance Programme. At international ordinary Events, national jurisdiction rules apply.*

##### **2. AUTHORITY AND DUTIES**

*The Protest Judge sits as long as the event lasts and hears all protests relating to that event. The Protest Judge must decide as soon as possible on all protests presented during the event.*

### **403 - PROTEST PROCEDURES**

#### **403.01 - VALIDITY OF PROTESTS**

*A protest shall be submitted in writing to the Protest Judge or a designated member of Race Direction within one hour after the conclusion of the session to which it refers. Protests submitted after this period will not be considered.*

*Only a rider may submit a protest, and only in relation to a race in which he or she has participated. In the case of a blue card, the penalized rider may protest against the penalty.*

*Joint protests signed by multiple riders will not be accepted.*

*All protests must be typewritten or handwritten in printed characters in English. They must clearly state the reason for the protest, include any supporting documents or evidence available within the submission time, and be accompanied by the protest fee as defined in the Protest Fee section of this Rulebook.*

*Each protest must be signed by the rider. The Protest Judge or designated Race Direction member shall, in the presence of the protester, record the official time of receipt.*

*Any costs incurred in verification shall be borne by the losing party.*

*A protest may be withdrawn in writing by the protester; in such a case the protest fee is forfeited.*

#### **403.02 - PROTEST FEE**

*The protest deposit is fixed at 150 EUR and must be handled out with the protest at the time of submission. The deposit shall be refunded if the protest is upheld; otherwise, it is forfeited.*

#### **403.03 - RIGHT OF PROTEST**

A protest can be lodged against the posted provisional results or against any decision made by the O.O.D. or against one or several competitors.

In the event of one driver protesting against a penalty imposed on him and/or one or more drivers protesting simultaneously against this competitor due to the same incident, the protest judge will have only one meeting with all concerned drivers being party of this protest procedure. The same applies if several drivers protest against the same protest judge decision.

A protest can only be lodged on a subject which directly concerns the protester himself. A protest which complies with these rules cannot be refused by the Protest Judge.

Only one follow-up-protest is allowed against a O.O.D. decision following an initial protest that was lodged according to the first paragraph of this rule. All parties of the initial protest will automatically become party to this follow-up-protest and must be invited to the hearing. No protest is permitted against a Protest Judge decision about a follow-up-protest. Such protest judge decision can only be contested by appeal.

#### **403.04 - TIME OF LODGING A PROTEST / PROTEST PERIOD**

A protest regarding the eligibility of a motorized surfboard, an engine, or a rider must be made before the first rider briefing.

Starting in a race is considered as acceptance of the conditions and the eligibility of the other competitors. The only exception to the above is when the protester can prove the facts were not given to him before the rider briefing, then a protest can be lodged up to one hour after the posting of the results.

Any other protest must be lodged within one hour of the first results being posted with the following exceptions:

A protest of a rider (rider "A") against another rider (rider "B") can be lodged within 60 minutes after conclusion of the particular session the protested situation happened. Without lodging such a protest, rider "A" shall not be entitled to appeal against the protest judge decision.

A protest against any other decision, posted after the posting of the first results can be lodged within one hour after the posting of this decision.

### **403.05 - JUDGEMENT**

Protest is to be decided by the Protest Judge. In the event of a protest, penalties may be agreed, rejected or changed by the protest judge. If a protest is upheld by the Protest Judge, the fee must be returned to the protester. Any judgement pronounced by the Protest Judge stays in effect until altered by the Appeal Board.

### **403.06 - NOTIFICATION OF DECISION**

All decisions by the protest judge, the minutes of the meeting and the justification of the decision must be notified to the concerned parties in writing, including their right of appeal. A copy of the Protest Judge decision must be posted in the same way as the results. The time of posting must be noted on this copy.

## **404 - HEARING OF THE PROTEST**

### **404.01 - RIGHT TO A HEARING**

Any Person being party to a protest or being charged for an offence against the rules shall have the right to be heard before the Protest judge in order to defend himself.

### **404.02 - WITNESSES AND EVIDENCE**

It is the responsibility of the parties involved in a protest to ensure that witnesses appearing on their behalf together with any other evidence are present and the Protest judge at his/her sole discretion may take their availability into account when determining the time of the hearing.

Any costs incurred by the appearance of witnesses shall be borne by the respective parties unless decided otherwise by the Protest judge.

In case there is no evidence of protested action, such protest shall be closed as a racing incident.

### **404.03 - THE HEARING PROCEDURE**

The following procedure must be followed in all hearings unless otherwise stated elsewhere in these rules:

A copy of the protest must be posted in the same way as the results. The time of posting must be noted on this copy. Together with a copy of the protest, the Protest Judge must give written notice to all parties of where and when the hearing will take place. Reasonable time shall be allowed to the parties for the preparation to the hearing. If any party duly notified, fails to appear without giving an acceptable reason, judgement can be rendered by default i.e., the missing party shall lose the protest.

Written minutes must be taken. Using the services of a secretary for taking minutes for Protest Judge is allowed. The Secretary has no right to vote or act as interpreter. All parties to the case are entitled to be present and to hear and question all evidence at the hearing up to the time the Protest judge makes its decision.

If the hearing meeting involves a junior (less than 18 years of age) then he/she must be accompanied throughout the meeting by an adult (parent/guardian).

The protest shall be read out to the parties. A party to the hearing who believes that a member of the Jury is an "interested party" or otherwise not suitable to decide upon the protest shall object at the beginning of the hearing and before he/she states his/her own case.

Failing to do so will result in acceptance of the relevant jury member unless the party can prove that the circumstances and facts resulting in the Ineligibility of the jury member came to his/her knowledge only after this moment. In this case the party has to object immediately after having obtained the relevant information. Then the Protest Judge shall decide whether all formal requirements of the protest are fulfilled. Failures shall lead to the protest being void. The parties shall be given the opportunity to give statements if failures are found and before a final decision on the formal legality of the protest is taken.

The parties shall be invited to state their cases. The parties may call witnesses. Each witness, after having given his/her account of the case, may be questioned by all parties and by the Protest judge. Any other evidence available may be presented.

The witnesses shall withdraw and the parties shall be invited to make a final statement of their cases.

The Protest Judge may recall any party, previous witness or new witness and call on any other evidence to verify the facts. The parties must be present during the whole of the recall and must be given the opportunity to question any new evidence after which they may re-make their final statements. After all evidence has been assessed the situation with the protest may be discussed. The hearing will then be closed and the Jury shall debate the case and take decision.

## **405 - THE APPEALS PROCEDURE**

Unless stipulated differently below, the rules for the protest procedure shall apply to the appeals procedure as well.

With reference to the appeals procedures, any time limits which end on a Saturday or Sunday shall end on the following Monday. If the Appellant misses any time limit the appeal will be rejected as void.

The UIM will decide on Appeals arising from International events according to the "UIM International Court of Appeal".

The UIM will not decide on Appeals arising at UIM International Ordinary Events. Such appeals will be handled by the organizing National Authority according to applicable national rules for Appeals.

### **405.01 - UIM INTERNATIONAL COURT OF APPEAL (ICA)**

The ICA sits whenever the Chairman calls a meeting.

### **405.02 - INTERESTED PARTIES**

No interested party shall be member of the ICA as set forth in the ICA rules.

### **405.03 - RIGHT OF APPEAL**

A decision by a Protest Judge may be appealed by the parties involved in the hearing meeting when they consider that an injustice has been made against them and/or fresh evidence has been made available that may alter the decision of the Protest judge.

A rider can also appeal a penalty imposed against him without the prior lodging of a protest, but only if this was not possible, because the protest judge has been dismissed before or within the protest period.

#### **405.04 - NOTICE OF INTENTION TO APPEAL**

The intention to appeal must be notified in writing to the Secretariat of the UIM by the interested party within four days of the day following the Protest judge decision or in the case of a decision against which a rider can appeal without the prior lodging of a protest within four days of the day following the notification of this decision to the NA of the rider or if earlier to the rider concerned.

#### **405.05 - THE TIME LIMIT**

All appeal documents and fees must be received within ten days from the date when the notice to appeal was received by the UIM Secretariat.

#### **405.06 - LODGING OF AN APPEAL**

The appeal must be sent by letter or E-mail and it must be signed by the appellant. The reasons for the appeal must be stated.

Address, telephone and e-mail should be clearly mentioned on the appeal, so that the UIM can send any correspondence directly to the rider with copy to relevant N.A.

#### **405.07 - NOTIFICATIONS OF THE PARTIES OF THE APPEAL**

The UIM Secretariat must within two days from receiving the appeal, notify by letter ( e mail) the other parties that an appeal has been lodged and that they may send a rejoinder. Eventual rejoinders must be received within ten days from receiving this notification.

#### **405.08 - TIME LIMIT FOR DECISION ON APPEALS**

All appeals must be determined no later than forty-five days after the date when the appeal documents and fees were received by the UIM Secretariat.

#### **405.09 - UIM INTERNATIONAL COURT OF APPEAL**

The ICA takes its own decision based on every information available. The decision of the jury may be upheld, changed or not upheld. The decision of the ICA is final.

#### **405.10 - COSTS**

For titled international championship series or for events which require a UIM Serial Licence, the appeal fee is 2000€. In addition, the rider has to pay 2000 € to the UIM for possible costs of the ICA (IT meeting arrangements, telephone, laboratory, experts and other costs of the appeal procedure).

If the appellant requests the appeal procedure to be conducted in physical presence of the persons involved, related extra costs in excess of the deposit of 2000 € shall be at the charge of the appellant.

The appeal fee for a single UIM Event championship is 1000 €, in addition the rider has to pay 1000 €, to the UIM for possible costs of the ICA.

If during the procedure further costs arise, the Appellant has to deposit the missing amount accordingly with 14 days from notification.

The rider who appeals has to pay for the meeting costs anyway if the appeal is upheld or not. If the costs of the appeal procedure amount to less than defined above then the difference will be paid back to the rider.

The appeal fee will be refunded if the appeal is upheld. In case driver appeals because the race Jury has been dismissed before or within the protest period, appeal fee and deposit for handling cost is 50% from defined above in this rule.

If the original decision is changed by the ICA it can decide to refund a percentage of the appeal fee if appropriate. If there is an infringement to, the Chairman of the ICA can decide that the appeal is not considered valid since the deadlines were not respected. In this case 50 % of the received appeal fee will be reimbursed to the appellant. Further appeal fees or deposits as foreseen in the ICA rules do not apply.

## **406 - UIM PENALTIES**

### **406.01 - GENERAL**

Any proven breach of applicable Rules may be penalised. If the rules do not determine a special penalty for the relevant breach, the penalty to be given has to be proportional to the seriousness of the breach. The proportionality is at the discretion of the decision maker.

The UIM Executive Committee or the relevant National Authority shall only impose penalties, when they deem the relevant infringement to be so serious, that it has to be penalized although the deadlines for penalizing or lodging a protest have already expired. After the expiry of the aforementioned deadlines, a penalty for an ordinary breach of the rules shall in general not be imposed. The Protest judge or the ICA following a protest or an appeal can (only) impose penalties.

### **406.02 - DEADLINES FOR PENALIZING**

The first posted results are provisional for one hour. The National Authority and/or the UIM Executive Committee can only impose penalties within 3 months from the day, the infringement occurred.

These deadlines are not valid for penalties imposed by the Protest Judge for the reason of post race technical scrutinizing and under the condition that this is stated on the results sheet. In this case, the results will remain provisional until one hour after the finalization of the post race scrutineering.

The date and time of finalization of the post race scrutineering must be recorded by the Technical Scrutineer or other technical scrutinizer in charge.

If the post race scrutineering cannot be finalized until the end of the Event and the Protest Judge has already left the race site, the penalty has to be imposed as soon as possible after the receipt of the scrutinizing results.

### **406.03 - UNACCEPTABLE BEHAVIOUR**

In order to protect the interests of the sporting community, the following actions may also be penalised by the Protest Judge, by the UIM Executive Committee or by the NA of the Licence Holder.

- any deliberate act taken to gain unfair advantage.
- any false act made or statement given with the intention of suppressing facts required for the proper conduct of the race.
- any Attempt to bribe or the taking of a bribe.
- any abusive or unsportsmanlike behaviour.

#### **406.04 - REPRIMAND**

A Reprimand is a notice of disapproval of an unacceptable action. It must be recorded by the Race Direction.

A reprimand must be witnessed. A reprimand automatically constitutes warning that if the offence recurs, a heavier penalty will be given. A Reprimand is valid for 12 month. A reprimand can be given by the Protest Judge, or the National Authority of the Licence Holder.

#### **406.05 - YELLOW/RED/BLUE CARDS**

A yellow or red card may be given by the O.O.D. or the UIM Commissioner. A yellow or red card will be confirmed on UIM form which will be posted with the results and if it is confirmed it must be included in the commissioners report. The recipient must be notified privately before a red card or yellow or blue is posted.

The driver has one hour from the posting of the penalty to protest. If the protest is not upheld, he/she can make an appeal. A yellow/red card received in all UIM disciplines and classes count towards the drivers CV and shall be accumulated.

Yellow/red cards can only be given for bad behaviour on the water including:

- up to two yellow cards at a time for dangerous driving.
- one red card for extreme blatant dangerous driving.

A driver who receives a red card is immediately disqualified from that event.

Receiving a third yellow card equals to a red card and carries the same penalties/actions. A driver with a red card shall lose the right to take part in any UIM activities on the water for two months. In addition, during the two years following the receipt of the card, he/she is not eligible for the first UIM titled race in the discipline or class in which he/she received the card. Further penalties may be applied on a national level by the driver's NA.

All yellow cards will remain valid for the four UIM events (any UIM sanctioned races, titled or not) in which he/she competes following the date on which the last yellow card was delivered or 36 calendar months from this date. Yellow/red cards must be notified to the UIM and National Authority of the competitor concerned within three days of completion of the event. The UIM will notify all National Authorities when a driver has a red card and is therefore suspended from international competition.

To be applied to all people in the paddock and to UIM competitors also out of competition:

A blue card can be given by the UIM commissioner/ OOD/ UIM Race Director for any offensive, unsportsmanlike, abusive etc, behavior during an event. Two blue cards may be given for blatant and unlawful misconduct.

Blue card(s) can also be given by the relevant UIM Commission or Committee, by the UIM Executive Committee or by the NA of the competitor for any offensive, unsportsmanlike, abusive and herby unlawful behavior committed in the media or in any other way vis a vis the public and in relation to UIM, UIM officials, promoters, local organizers.

A blue card will remain valid for one year from the date of issue. A second blue card leads to disqualification (if issued against a driver) from all results obtained at the event where the incident occurred and to suspension from the rest of the event and from all UIM titled races in all disciplines or classes as a driver or team member for the next 4 weeks. If the second blue card is given for out of competition activity the penalty will be prolonged suspension for one future event, designated by the same body that issued the second blue card.

#### **406.06 - DISQUALIFICATION**

Disqualification deletes a competitor from the results of the heat or race where the offence occurred. Disqualification is done by the Race Direction.

#### **406.07 - TEMPORARY SUSPENSION**

Temporary suspension suspends a competitor, a competitor together with crew, a crew member, or an Official from all or part of an Event. Temporary Suspension may be given for serious indiscipline. Temporary Suspension will be imposed by the Race Direction.

#### **406.08 - PROLONGED SUSPENSION**

Prolonged suspension can be imposed on a competitor, an Official or an organisation for deliberate fraud, repeated or very serious indiscipline or very serious misconduct. Prolonged Suspension can be imposed only by the NA of the licence holder or organisation, or by the UIM Executive Committee. A Prolonged Suspension is always International. The NA must immediately inform the UIM of a Prolonged Suspension and the UIM must inform all other NA's.

#### **406.09 - EXCLUSION**

Exclusion means a permanent loss of all rights to take part in any activities falling under the UIM and its affiliated organisations. A Person or an organisation who has committed a moral or sporting offence of extreme gravity is liable to be excluded. A sentence of exclusion can be pronounced only by the NA of the licence holder or organisation, or by the UIM Executive Committee. Exclusion is always International. The NA must immediately inform the UIM when it has imposed a sentence of Exclusion and the UIM must inform all other NA's. In the case of suspension, prolonged suspension or exclusion, all National Authorities and therefore their affiliated clubs bind themselves to respect the decision and apply it in their own country.

### **407 - PRIORITY OF THESE RULES**

The course of the UIM has to be exhausted, before the dispute can be brought before civil court.

### **409 - ARBITRATION**

Any decision rendered by the UIM International Court of Appeal ("ICA") may be appealed exclusively before the Court of Arbitration for Sport ("CAS") in Lausanne, Switzerland, which shall have final authority to resolve the dispute in accordance with the Code of Sports-related Arbitration.

The time limit for filing an appeal at CAS is fifteen (15) days from the date of receipt of the full reasoned verdict issued by the ICA.

All CAS administrative and arbitration-related costs and fees shall be borne entirely by the Appellant, unless the final arbitration award provides otherwise and orders the UIM to reimburse part of such costs.

The applicable law shall be that of Monaco, and the language of the proceedings shall be English.

## **500 - TECHNICAL RULES**

To be able to participate in the event, every rider has to pass a technical inspection of his/her surfboard. The technical inspection is carried out during the registration process.

After successfully passing the technical inspection and safety features equipment check, the rider receives a sticker on all particularly checked equipment which is valid for the event when the inspection took place.

A Rider who does not have such label/sticker on the inspected equipment, will not be admitted to the race. Technical inspection has to check the level of preparation and safety of the individual equipment and consists of three parts:

- a) Technical inspection of the board
- b) Inspection of safety gear
- c) Compliance with technical specification for each category.

Passing of the technical control does not guarantee the checked board remains in compliant conditions for each class for the entire race weekend. The surfboard can be further checked as in section Parc Fermé. Technical inspection is performed by a UIM MotoSurf authorized technician. The technical inspection shall be performed on the following features and areas of the motorized surfboards:

### **501 - ELITE *MEN* & MASTERS *MEN* CATEGORIES**

#### **501.01 - GENERAL REQUIREMENTS**

- a) Every surfboard participating in the UIM MotoSurf competitions shall be in a good technical shape that allows its complete control and does not represent any danger to any of the participating riders and event personnel.
- b) Every surfboard participating in the UIM MotoSurf competitions shall have enough power to allow its rider to use it in the standing position operating in gliding mode.
- c) None of the manufacturers shall clash any patent or trademark right with other competing manufacturers. Each manufacturer shall sign an affidavit about this statement and the Promoter is authorized to request the documents stating and documenting such condition.
- d) Each board registered to the race weekend shall be based on the production type of the board coming from each particular manufacturer. Competing with a prototype board is not allowed. Based on request from the Promoter, each manufacturer is obliged to prove that the particular type of the board registered into the competition has been previously produced in minimum volume of 50 pieces.
- e) Each board registered to the competition must have its genuine number of the engine and on the hull. Such number shall be shown to the Technical Scrutineer based on request. Missing of such number shall lead to denial of registration process and preventing from labelling the board with approving sticker.

#### **501.02 - ENGINE REQUIREMENTS**

- a) Maximum allowed displacement of two-stroke engine is 106 ccm,
- b) Maximum allowed displacement of four-stroke engine is 212 ccm,
- c) The power unit shall be built as a single cylinder. Condition for a single cylinder motor is valid for two – stroke as well as four – stroke engines.
- d) The combustion engines have to be Naturally aspirated (not supercharged).
- e) N2O (NOS) is not allowed, for any of the competing surfboards.

### 501.03 - HULL REQUIREMENTS

- a) Maximum length of the board is 200 cm.
- b) Integrity check - Hull of the motorized surfboard must be in a state of no scratches, cracks or damage that could potentially lead to instability of the surfboards construction.
- c) Handle and throttle cable check
- d) The jetpump impeller of any surfboard must be integrated to the jet pump tunnel of the hull of the surfboard in order to avoid any damages caused by sharp ends of the impeller.
- e) Fuel system check (complete tank and fuel system must be EPA certified)

### 501.04 - WEIGHT REGULATIONS

- a) The maximum mass of the motorized surfboard without a fuel tank is 30 kg.

### 501.05 - FINS REQUIREMENTS

- a) Fins integrity check – there must not be any visible carbon burrs and cracks,
- b) Shape of each fin shall be without any toothed shape larger than 1 cm in order to ensure the safety of other riders. (as in Picture 1 in Appendix 1)
- c) The main fin shall comply with following dimensions (as in Picture 2 in Appendix 1):
  - Maximum height: 230 mm
  - Maximum length: 340 mm

### 501.06 - FUNCTIONAL CHECK OF THE SURFBOARD

- a) Shut-Off key functional check.
- b) Engine functions checks.

## 502 - STOCK **MEN** CATEGORY

### 502.01- GENERAL REQUIREMENTS

- a) The Stock **Men** Category is a completely production-oriented category. The only surfboards allowed in the Stock **Men** Category are the JetSurf Titanium DFI 2021, JetSurf Titanium DFI 2022, JetSurf Titanium DFI 2023, JetSurf Titanium DFI 2024 and JetSurf Titanium DFI SL 2025 in their standard specifications **following manufacturer's technical specifications published in Appendix 2**. Allowed modifications are specified in point 502.06 of this rulebook.
- b) Every surfboard participating in the UIM MotoSurf competitions shall be in a good technical shape that allows its complete control and does not represent any danger to any of the participating riders and event personnel.
- c) Every surfboard participating in the UIM MotoSurf competitions shall have enough power to allow its rider to use it in the standing position operating in gliding mode.
- d) None of the manufacturers shall clash any patent or trademark right with other competing manufacturers. Each manufacturer shall sign an affidavit about this statement and the Promoter is authorized to request the documents stating and documenting such condition.

### 502.02 - ENGINE REQUIREMENTS

- a) Features not allowed by sections of this rulebook are prohibited.
- b) The engine has to be in standard configuration as in JetSurf Titanium DFI 2021, JetSurf Titanium DFI 2022, JetSurf Titanium DFI 2023, JetSurf Titanium DFI 2024 or JetSurf Titanium DFI SL 2025 specifications, **following manufacturer's technical specifications published in Appendix 2.**
- c) Each engine to be registered in the Stock **Men** class must be previously sealed by the manufacturer. The sealing consists of sealing screws set. Only fully sealed and non-damaged seals engines sets will be accepted to the race. It is responsibility of every rider to secure sealing with the manufacturer or make sure the engine and exhaust set is sealed before the technical inspection in the time window announced in the time schedule of the race.
- d) In case the sealing has to be removed for purposes of servicing of the board during the event, it is necessary the engine is sealed again for the next session the rider is going to attend. In case the sealing is removed during the events, it is rider's responsibility to make sure the engine set is re-sealed before the event by the event or in the time window for sealing announced by the Promoter in the time schedule of the racing weekend.
- e) If the Stock **Men** Class board has been successfully checked for its seals during the technical inspection, the Technical Scrutineer will install a seal on engine mounting to prevent further manipulation with the engine outside of the hull. Damaging of such seal without approval of Technical Scrutineer will be penalized according to penalties for breaching the Stock **Men** class conditions. Such seal can be opened only by the Technical Scrutineer only for service purposes of the engine.
- f) Previously sealed engines (2021, 2022, 2023, 2024, 2025) that were never unsealed or re-sealed engines by the service team of the MSWC will be accepted as valid engine sealing for the Stock **Men** Class.
- e) Technical specification will be published by the manufacturer and is only relevant source of technical shape required for the Stock **Men** Class.

### 502.03 - HULL REQUIREMENTS

- a) The hull specification shall be as in JetSurf Titanium DFI 2021 or JetSurf Titanium DFI 2022 or JetSurf Titanium DFI 2023 or JetSurf Titanium DFI 2024 or JetSurf Titanium DFI SL 2025.

### 502.04 - FINS AND FINS ADJUSTORS REQUIREMENTS

- a) Fins integrity check – there must not be any visible burrs and cracks,
- b) Main fins up to length of 230 mm (from base to the bottom) and maximum length of 340 mm. The scheme of the measures of the main fin as in Picture 2 in Appendix 1.
- c) Side fins adjustors are permitted. The fins adjustors have to be available on publicly accessible market place. Prototype fins adjustors are not accepted. The rider can be asked to prove the availability of used fin adjustor by the Technical Scrutineer or protest judge.
- d) Side fins for the Stock **Men** category must be FCS fins compatible with approved adjustors. No other fins will be accepted.
- e) Shape of each fin has to be without any toothed shape larger than 1 cm in order to safely protect other riders. (as in Picture 1 in Appendix 1)

**502.04.01 - CONTROL PROCEDURE OF THE FIDE FINS**

- a) The Technical Scrutineer checks the side fins and their compliance with rule Nr. 502.04.
- b) The Technical Scrutineer has right to evaluate potential danger by using a non-standard fin which might be too sharp or made from a dangerous material. Such evaluation is on expertise of the Technical Scrutineer. Technical Scrutineer is authorized to decide about safety of the used fins and is authorized not to accept fins that will be evaluated as dangerous even if such fins meet the required dimensions.

**502.05 - FUNCTIONAL CHECK OF THE SURFBOARD**

- a) Kill switch functional check.
- b) Engine functions checks.
- c) Engines / engines sealings compliance check.

**502.06 - ALLOWED MODIFICATIONS**

The following elements can be modified:

- a) Pads & Straps
- b) Throttle controller length
- c) Shut-off key protector installation on the throttle controller.
- d) Main fin & Side fins as in Art. 502.04 (& as in Pictures 1 and 2 in Appendix 1)
- e) Graphic design
- d) Ball mounting in the exhaust can be removed
- e) Fins adjusters

**502.07 - GENERAL CONCLUSION**

Every rider joining the Stock **Men** class agrees with the conditions defined in Art. 502.01.

In case the inspected features on the board are not compliant with the technical description of the Stock **Men** Class board, such rider shall be automatically moved to the Elite **Men** Class or penalized according to penalties for breaching the Stock **Men** class conditions.

## 503 - **ELITE WOMEN & MASTERS WOMEN CATEGORIES**

### 503.01 - GENERAL REQUIREMENTS

- a) Every surfboard participating in the UIM MotoSurf competitions shall be in a good technical shape that allows its complete control and does not represent any danger to any of the participating riders and event personnel.
- b) Every surfboard participating in the UIM MotoSurf competitions shall have enough power to allow its rider to use it in the standing position operating in gliding mode.
- c) Every surfboard participating in the UIM MotoSurf competitions shall have enough power to allow its rider to use it in the standing position operating in gliding mode. None of the participants in the **Elite Women and Masters Women** categories can race on the JetSurf Titanium DFI. Every rider shall race on a surfboard produced in at least a 50 pieces production batch in order to inform the Promoter that the used surfboard is production based, and not prototype based.
- d) Only the Jetsurf Race and Jetsurf Race DFI in their standard specifications are accepted to the **Elite Women and Masters Women** categories, **following manufacturer's technical specifications published in Appendix 3**. Allowed modifications are specified in point 503.07 of this rulebook.

### 503.02 - ENGINE REQUIREMENTS

- a) Features not allowed by sections of this rulebook are prohibited.
- b) The engine shall be in standard configuration as in JetSurf Race DFI 2021 or JetSurf Race DFI 2022 or JetSurf Race DFI 2023 or JetSurf Race DFI 2024 or JetSurf Race DFI SL 2025 specifications, **following manufacturer's technical specifications published in Appendix 3**.
- c) Each engine registered into the **Elite Women and Masters Women** classes must be previously sealed by the manufacturer. The sealing consists of sealing screws set. Only fully sealed and non-damaged seals engines sets will be accepted to the race. It is responsibility of every rider to secure sealing with the manufacturer or make sure the engine and exhaust set is sealed before the technical inspection in the time window announced in the time schedule of the race.
- d) In case the sealing has to be removed for purposes of servicing of the board during the event, it is necessary the engine is sealed again for the next session the rider is going to attend. In case the sealing is removed during the events, it is rider's responsibility to make sure the engine set is re-sealed before the event by the event or in the time window for sealing announced by the Promoter in the time schedule of the racing weekend
- e) If the **Elite Women or Masters Women** classes board have been successfully checked for its seals during the technical inspection, the Technical Scrutineer will install a seal on engine mounting to prevent further manipulation with the engine outside of the hull. Damaging of such seal without approval of Technical Scrutineer will be penalized according to penalties for breaching the Stock **Men** class conditions. Such seal can be opened only by the Technical Scrutineer only for service purposes of the engine.
- f) Previously sealed engines (2021, 2022, 2023, 2024, 2025) that were never unsealed or re-sealed engines by the service team of the MSWC will be accepted as valid engine sealing for the **Elite Women and Masters Women** classes.
- g) Technical specification will be published by the manufacturer and is only relevant source of technical shape required for the **Elite Women and Masters Women** classes.

### 503.03 - HULL REQUIREMENTS

- a) Maximum length of the board is 200 cm.
- b) None of the manufacturers shall clash any patent or trademark right with other competing manufacturers. Each manufacturer shall sign an affidavit about this statement and the Promoter is authorized to request the documents stating and documenting such condition.
- c) Integrity check - Hull of the motorized surfboard shall be in a state of no scratches, cracks or damages that could potentially lead to the instability of the surfboards construction.
- d) Handle and throttle cable check, testing the handle in salt water (against spontaneous turning on)
- e) The jetpump impeller of any surfboard must be integrated to the jet pump tunnel of the hull of the surfboard in order to avoid any damages caused by sharp ends of the impeller.
- f) Fuel system check (complete tank and fuel system shall be EPA certified)

### 503.04 - WEIGHT REGULATIONS

- a) The maximum mass of the motorized surfboard without a fuel tank is 30 kg.

### 503.05 - FINS REGULATIONS

- a) Fins integrity check – there must not be any visible carbon burrs and cracks,
- b) Shape of each fin has to be without any toothed shape larger than 1 cm in order to safety protection of other riders.
- c) The main fin shall comply with following dimensions (as in Picture 2):
  - Maximum height: 230 mm
  - Maximum length: 340 mm
- d) The allowed side fins for the **Elite Women** and **Masters Women** categories are all the FCS fins compatible with provided adjustors. No other fins will be accepted. Only officially certified FCS fins are allowed.

### 503.06 - FUNCTIONAL CHECK OF THE SURFBOARD

- a) Shut-off key functional check
- b) Engine functions checks.
- c) Engines / engines sealings compliance check.

### 503.07 - ALLOWED MODIFICATIONS

The following elements can be modified:

- a) Pads & Straps
- b) Throttle controller length
- c) Shut-off key protector installation on the throttle controller.
- d) Main fin & Side fins as in Art. 503.05.
- e) Graphic design.
- f) Ball mounting in the exhaust can be removed.

## 504 - JUNIORS BOYS & JUNIORS GIRLS CATEGORIES

### 504.01 - GENERAL REQUIREMENTS

- a) Every surfboard participating in the UIM MotoSurf competitions shall be in a good technical shape that allows its complete control and does not represent any danger to any of the participating riders and event personnel.
- b) Every surfboard participating in the UIM MotoSurf competitions shall have enough power to allow its rider to use it in the standing position operating in gliding mode.
- c) ***None of the participants in the Juniors Categories can race on the JetSurf Titanium DFI. Every rider shall race on a surfboard produced in at least a 50 pieces production batch in order to inform the Promoter that the used surfboard is production based, and not prototype based.***
- d) Only the Jetsurf Race, Jetsurf Race DFI in the standard specification is accepted to the Juniors category, ***following manufacturer's technical specifications published in Appendix 3. Allowed modifications are specified in Art. 504.07 of this rulebook.***

### 504.02 - ENGINE REQUIREMENTS

- a) ***Features not allowed by sections of this rulebook are prohibited.***
- b) ***The engine shall be in standard configuration as in JetSurf Race DFI 2021 or JetSurf Race DFI 2022 or JetSurf Race DFI 2023 or JetSurf Race DFI 2024 or JetSurf Race DFI SL 2025 specifications, following manufacturer's technical specifications published in Appendix 3.***
- c) ***Technical specification will be published by the manufacturer and is only relevant source of technical shape required for the Juniors Categories.***

### 504.03 - HULL REQUIREMENTS

- a) Maximum length of the board is 200 cm.
- b) None of the manufacturers shall clash any patent or trademark right with other competing manufacturers. Each manufacturer shall sign an affidavit about this statement and the Promoter is authorized to request the documents stating and documenting such condition.
- c) Integrity check - Hull of the motorized surfboard shall be in a state of no scratches, cracks or damages that could potentially lead to the instability of the surfboards construction.

### 504.04 - WEIGHT REGULATIONS

- a) The maximum mass of the motorized surfboard without a fuel tank is 30 kg.

### 504.05 - FINS REGULATIONS

- a) Fins integrity check – there must not be any visible carbon burrs and cracks,
- b) Shape of each fin has to be without any toothed shape larger than 1 cm in order to safely protect other riders.
- c) The main fin shall comply with following dimensions (as in Picture 2):
  - Maximum height: 230 mm
  - Maximum length: 340 mm
- d) ***The allowed side fins for the Juniors categories are all the FCS fins compatible with provided adjustors. No other fins will be accepted. Only officially certified FCS fins are allowed***

## 504.06 - FUNCTIONAL CHECK OF THE SURFBOARD

- a) Kill switch functional check.
- b) Engine functions checks.
- c) **Engines / engines sealings compliance check.**

## 504.07 - ALLOWED MODIFICATIONS

*The following elements can be modified:*

- a) **Pads & Straps**
- b) **Throttle controller length**
- c) **Shut-off key protector installation on the throttle controller.**
- d) **Main fin & Side fins as in Art. 504.05**
- e) **Graphic design.**
- f) **Ball mounting in the exhaust can be removed.**

## 505 - ELECTRIC CHALLENGE CATEGORY

### 505.01 - ELECTRONIC REQUIREMENTS

- a) Maximum voltage of fully charged battery must not exceed 60 V.
- b) Maximum mass of the board including battery pack must not exceed 45 kg.
- c) Power unit must have a safety shut off key. In case of wireless throttle controller, such controller has to shut off the engine immediately after being dropped from the rider's control. Any type of system has to be presented to the commissioner during the technical inspection.
- d) Every motorized surfboard must be ready and accessible to check technical dimensions for the needs of the Race Direction.

### 505.02 - CHARGER REQUIREMENTS

- a) Each charger must be CE certified and compatible to charge from the standard A household electrical outlet (from the ground event).
- b) Charger unit and its wiring for each board has to be made from heavy duty isolated materials in order to prevent danger of fire.
- c) Charger unit has to be equipped with signalization of failures in order to predict an emergency situation during the charging process. The charger has to monitor following measures:
  - Temperature inside the battery
  - Humidity inside the battery
  - Pressure inside the battery
  - Voltage on the battery terminals
 For charging and storage of the battery, all measures as in point c) of this article have to be monitored. Based on the AMSM, the critical values will be defined.

\*AMSM – Association of Motorized Surfboards Manufacturers

### 505.03 - BATTERY PACKS REQUIREMENTS

Maximum number of allocated battery packs for each surfboard is 3 (three) for the duration of the entire event. Such batteries shall be labelled. Additional number of batteries will not be accepted for the duration of the event.

- a) Requests for additional number of battery packs during the event will not be accepted
- b) In case any battery pack becomes non-functional during the event, and such failure is tested and accepted by the Technical Scrutineer, one more battery will be accepted and labeled for the event.
- c) If a racer joins session with the battery without a label on the battery, the rider is disqualified from so far concluded session in the current racing weekend.
- c) Every battery pack has to be able to provide following data:
  - CAN BUS 2.0, speed 500kB (format Motorola, Big Endian)
  - ID 500h or 600h or 700h DLC 8
    - unsigned word, byte 0, byte 1 – current battery voltage (step 0.01V),
    - signed word, byte 2, byte 3 – current battery voltage (step 0.1A)
    - unsigned word, byte 4, byte 5 – current motor EPM (step 1 RPM),
    - unsigned word, byte 6, byte 7 – current throttle position v % (step 1 %)
  - data must be collected via unified connector \*XXX, (1 - CAN L, 2 - CAN H, 3 - CAN GND, 4 – power supply 12V)
  - every board must secure a place on the hull for attaching a datarecording unit, such place must not be prevented from GPS signal reception
  - every manufacturer must secure connection of the unit for secondary measurements:
    - connector \*XXX, (1 - CAN L, 2 - CAN H, 3 - CAN GND, 4 – power supply 12V)
    - battery terminal voltage separated by a 100R resistor,
    - current sensor

\*harmonized connector type which is defined by the AMSM (Association of Motorized Surfboards Manufacturers).

### 505.04 - HULL REQUIREMENTS

- a) Length of the surfboard must not exceed 200 cm.
- b) Width of the surfboard must not exceed 80 cm.
- c) Motorized surfboard must not contain any sharp edges that could potentially harm other riders on the track during racing manoeuvres and procedures.
- d) All equipment of the motorized surfboard must not contain any sharp edges in order to protect the safety of the riders.
- e) Side and central fin configuration of each surfboard has to be compliant with standard configuration and specification of the manufacturer.
- f) Shape of each fin has to be without any toothed shape larger than 1 cm in order to safety protection of other riders. (As in Picture 1 in Appendix 1)
- g) The main fin shall comply with following dimensions (as in Picture 2 in Appendix 1):  
Maximum height: 230 mm, Maximum lenght: 340 mm
- h) Maximum number of the fins on the board must correspond with the production standards of each manufacturer.
- i) The jet pump impeller of any surfboard must be integrated to the jet pump tunnel of the hull of the surfboard in order to avoid any damages caused by sharp ends of the impeller.

### 505.04 - FINS REQUIREMENTS

- a) Fins integrity check – there must not be any visible carbon burrs and cracks
- b) Shape of each fin has to be without any toothed shape larger than 1 cm in order to safety protection of other riders. (as in Picture 1 in Appendix 1)
- c) Fins integrity check – there must not be any visible burrs and cracks
- d) Only officially certified FCS fins are allowed.

## 506 - ADDITIONAL RULES FOR STOCK **MEN** AND **ELITE** WOMEN CATEGORIES

### 506.01 - ENGINES DRAWING PROCEDURE

The below described procedure applies to only the 5 riders with provided propulsion kits.

- Riders currently ranked in the TOP 5 standings in the Championship are assigned the engine set by draw before the event, during the technical inspection.
- The engine set consists of Fuel Tank, ICU unit, sealed engine, exhaust (hereinafter “propulsion kit”).
- The board without the propulsion kit is brought individually by the athlete.
- The engines are drawn according to the numbers put into a drawing drum. The order of the draw is randomly decided by the O.O.D.
- After the draw of the propulsion kit, the kit is mounted to the board in the area designated by the Promoter.
- Each rider can decide whether the propulsion kit is mounted by the technical staff of the Promoter or by a mechanic chosen by the rider.
- If a rider chooses a mechanic to mount the propulsion kit, the name has to be announced and marked by the UIM Commissioner right after the rider has drawn the number of the propulsion kit.
- Once the propulsion kits are drawn and the technicians are allocated to each racer, the propulsion kits are mounted in the area designated by the promoter, under supervision of the technical staff of the Promoter.
- None of the mechanics or technicians is authorized to make any changes on the provided propulsion kits, connect diagnostics or conduct any changes on the unit – a breach of this rule will lead to disqualification of the rider whose propulsion kit is being mounted.
- Riders with the provided propulsion kits are under supervision of the technical staff of the Promoter. Such riders store the boards in designated area and protected area of the Promoter. The riders can manipulate with their boards for cleaning or preparation for the session only in times announced at the first briefing of the day and under supervision of the technical staff of the Promoter.
- Refueling of the boards with provided propulsion kits is made only in the area designated by the Promoter where the boards are stored.
- After the last session of the weekend and after finishing the “Parc Fermé” procedure, riders have to remove the propulsion kit off the board. Removal of the propulsion kit is conducted in the designated area of the Promoter. Each rider can decide if the removal is conducted by the technical staff of the Promoter or by a mechanic chosen by the rider.
- If the removal is conducted by a mechanic chosen by the rider, such person conducts the removal under supervision of the technical staff of the Promoter. It is strictly forbidden to conduct any changes on the propulsion kit.
- When the propulsion kit is removed, it is immediately handed over to the assigned technical commissioner, who seals the engine into the designated boxes for the propulsion kits.
- At the next following event, a new draw is conducted by the current top 5 riders in the Championship. At the first event of the season, the top 5 riders to be assigned the “propulsion kit” by draw are determined on basis of the final ranking of the previous season.

## 507 - TECHNICAL INSPECTION OF SAFETY GEAR

Inspection of security features is conducted by the Technical Scrutineer of the race. The inspection is focused on the following:

### 507.01 - ELITE *MEN*, STOCK *MEN*, MASTERS *MEN*, ELECTRIC CHALLENGE

- a) The wearing of a Helmet is mandatory, its intactness and integrity will be checked. A helmet will be always worn by all pilots when on the water. If a helmet does not meet the required standards of intactness and integrity the rider will not be permitted to race using this piece of equipment and a suitable alternative must be found. The helmet has to be of an integral type with jaw protection (motocross, downhill). A properly fitting helmet that meets current N.A. standard is required to be worn by all the riders in a competition.
- b) Goggles may be used.
- c) A life jacket will be worn by all pilots and at all times when on the water. It is required that the Life jacket shall be designed for racing. Every pilot shall verify his/her flotation equipment to function properly when requested.
- d) Neck brace is mandatory.
- e) Leash is mandatory.

### 507.02 - ELITE *WOMEN*, MASTERS *WOMEN*, JUNIORS BOYS, JUNIOR GIRLS

- a) The wearing of a Helmet is mandatory, its intactness and integrity will be checked. If a helmet does not meet the required standards of intactness and integrity the rider will not be permitted to race using this piece of equipment and a suitable alternative must be found. The helmet must be of an integral type with jaw protection (motocross, downhill). Only a helmet with CE homologation shall be accepted.
- b) Goggles may be used.
- c) A Life jacket will be worn by all pilots and at all times when on the water. It is required that the Life jacket shall be designed for racing. Every pilot shall verify his/her flotation equipment to function properly when requested.
- d) Neck brace is mandatory.
- e) Leash is mandatory.
- f) Shin protectors are mandatory.

## 508 - TECHNICAL INSPECTION IN PARC FERME

Parc fermé is closed area. One part where the riders line up before the sessions and the other part where the competitors must place the board for 6 minutes after the end of the sessions. The layout of the Parc fermé is designed to the specific race event. Violation of the rules of Parc Fermé is punishable by a warning, financial penalty or disqualification.

### SUPERVISED BOARDS (STOCK *MEN* & ELITE *WOMEN* CLASS)

- Every rider has right to choose up to 2 (two) mechanics for engine assembly but up to 1 (one) person authorized to enter parc fermé & supervised area (tent for supervised boards).

Such personnel is announced by rider the drawing session. In case there is a change of the personnel during the weekend, such change has to be requested to Supervised boards Technical Commissioner.

- After every session, every rider is required to stay in parc fermé for at least 6 minutes (time on the digital clock). The 6 minutes slot starts after last racer from the group the last has entered the parc fermé. Every rider is obliged to return to parc fermé at earliest possible convenience. The rider is requested to stay in the parc fermé area for the whole duration of 6 minutes time window. Earlier exit from the parc fermé will be penalized by financial penalty of 20 EUR.

Second penalty of the weekend is penalized with DNF from the last concluded session. After the 6 minutes parc fermé procedure, every rider is required to proceed to supervised area immediately where time window of 10 minutes is allocated for boards maintenance, cleaning, charger plug-in, refuelling etc.

Any other action is based on request at Supervised boards Technical Commissioner.

- Before every session, each rider is authorized to enter the supervised area 20 minutes before his/her next sessions starts. Entrance has to be notified to Supervised boards Technical Commissioner. In this window, every rider is required to get ready and proceed to waiting area before the session starts.

- After last session of the day, every rider is required to flush the board and the engine not later than one hour after the session concludes.

- During the day, when the supervised area is closed, none of the racer, nor mechanics, nor helpers – in general, none of the rider's authorized personnel, is allowed to enter the supervised area unless approved by the Supervised boards Technical Commissioner

- On Sunday, after the final session of the day, each rider is required to flush the engine, the board, and to disassemble the engine for return to Supervised boards technical commissioner at earliest possible convenience, but no later than 30 minutes before the podium ceremony starts (according to schedule).

- Supervised boards Technical Commissioner is authorized to appoint the official service technicians to perform control procedure whenever it is necessary.

- Technical Commissioners in Parc Fermé / Supervised Area have right to require longer waiting time in the area / other organization matter and perform any check or require other procedures if Technical check is needed or situation requires such action.

### **NON-SUPERVISED BOARDS**

- Every rider has right to choose 1 (one) person authorized to enter parc fermé. Such personnel is approved by the rider when asked by the Technical Scrutineer.

- After every session, every rider is required to stay in parc fermé for at least 6 minutes (time on the digital clock) The 6 minutes slot starts after the last racer of the currently going group has entered the parc fermé. Every rider is obliged to return to parc fermé at earliest possible convenience. The rider is requested to stay in the parc fermé area for the whole duration of 6 minutes time window. Earlier exit from the parc fermé will be penalized by financial penalty of 20 EUR.

Second penalty of the weekend is penalized with DNF from the last concluded session. After the 6 minutes parc fermé procedure, every rider is required to proceed exit the Parc Fermé.

- Technical Commissioners in Parc Fermé have right to require longer waiting time in the area and perform any check or require other procedures if Technical check is needed or situation requires such action.

## **600 - RECORDS AND PERFORMANCES**

*As in other UIM Sports Rulebooks, this section is reserved for Records and Performances regulations. Such MotoSurf records and performances regulations may be introduced in the future.*

## **700 - ENVIRONMENTAL REGULATIONS**

*As in other UIM Sports Rulebooks, this section is reserved for specific Environmental regulations. Such MotoSurf environmental regulations may be introduced in the future. In the meantime, please refer to the Facility Director's role (205.12) and to the UIM Environmental Code.*

## **800 - BASIC SERVICES AT THE EVENT – MOTOSURF WORLD CHAMPIONSHIP**

- **PADDOCK AREA**
- **PARC FERMÉ AREA**
- **WATER ENTRY / EXIT AREA**
- **SERVICE CENTER**
- **CLEANING AREA**
- **AREA FOR HANDLING GASOLINE – FUEL POWERED SURFBOARDS**
- **AREA FOR OVERNIGHT STORAGE**
- **FUEL – PETROL POWERED BOARDS**

*Further specification about the Venue Plan shall be attached and defined in the contract between the Promoter and the Organizer. Venue Plan with services shall be announced in the Advance Programme before every event.*

## **900 - E-FOIL MASTERS (SEPARATE EVENT)**

### **901 - GENERAL DESCRIPTION**

E-foil Masters is the latest addition to the electric racing section of the MotoSurf World Championship. Due to safety reasons, the E-foil Masters is raced on a separate race course on electric powered foils devices.

An eFoil is a watercraft that combines surfing, hydrofoiling and electric propulsion. A surfboard-like deck is equipped with a hydrofoil below the water's surface. The hydrofoil is connected to a powerful electric engine, usually mounted in a waterproof compartment beneath the board. This engine powers a propeller or jet at the base of the mast. The forward thrust that is created allows the rider to glide above the water's surface, without the need for wind or waves.

### **902 - E-FOIL TECHNICAL REQUIREMENTS**

- Only electric powered foils are allowed in the E-Foil Masters Category
- The maximum number of motors on the device is 3.
- Maximum voltage is 60 V
- Control handle is accepted remote and wired
- It is necessary the propeller on the foil is hidden and its sharp end are not uncovered
- The maximum width of the wind on the foil is 1m.

### **903 - RIDING GEAR REQUIREMENTS**

See article 8.

### **904 - HEAD TO HEAD RACING FORMAT**

#### **904.01 - FREE PRACTICE SESSION (FP)**

For the practices, riders are sorted into groups according to their championship standings. In the first race of the season, it will be according to the standings from the previous year. In case there are no standings available, riders are formed into FP groups based of decision of O.O.D.

#### **904.02 - THE QUALIFYING**

The qualification is one of the most important stages of the race. The best time, it means the winner of the qualification. From the qualifying, only the Top 14 (fourteen) riders proceed to next sessions of the race format.

There are two qualification laps for each rider. The direction of the ride depends on the previously announced direction. The best of the two marked qualifying laptimes.

Every rider starts the qualification session alone and makes a run of two laps. The best time of the two counts.

**904.03 - QUALIFYING LIMIT**

All competitors registered to the race enter the qualifying session. From the qualifying session, the TOP 14 (fourteen) proceed to head to head battle.

**904.04 - ROUND OF 14**

The first part of the Head to Head battle is session called: ROUND OF 14. Round of 14 (fourteen) riders will form pairs according to following scheme based on the qualifying results:

7th pair: 1st + 14th

6th pair: 2nd + 13th

5th pair: 3rd + 12th

4th pair: 4th + 11th

3rd pair: 5th + 10th

2nd pair: 6th + 9th

1st pair: 7th + 8th

Winner from each pair proceed to next session – Round of 8

**904.05 - ROUND OF 8**

The Round of 8 follows after ROUND OF 14. Winner of each round in Round of 14 proceed to the Round of 8. From the 7 pairs, there are 7 riders proceeding to the Round of 8 (eight).

**904.06 - FASTEST LOSER**

Fastest loser is the rider who did not win the pair battle in the Round of 14 but posted the fastest lap time of all remaining riders (8th fastest lap time in the session).

**904.07 - ROUND OF 8 STARTING GRID**

4th pair: 4th + 5th

3rd pair: 3rd + 6th

2nd pair: 2nd + 7th

1st pair: 1st + Fastest loser (8th fastest lap time from the Round of 14)

**904.08 - ROUND OF 4**

Winners from the TOP 8 shootout proceeds to the Round of 4 (four) and will form the final 4 that will compete for top three positions.

1st pair: 2nd + 3rd

2nd pair: 1st + 4th

**904.09 - FINAL ROUND**

## a) BATTLE FOR 3rd

Round of 4 1st Pair Loser + Round of 4 2nd pair Loser.

## b) BATTLE FOR 1st

Round of 4 1st Pair Winner + Round of 4 2nd Pair Winner.

**904.10 - RACE FORMAT GENERAL SUMMARY**

Each session of the Round of 14, Round of 8 and Round of 4, Battle for 3rd and Battle for 1st are held for 2 (two) laps. Two riders (pair) will start from the starting area based on the flag / traffic lights signalization. There are two parallel tracks –. After the start, one rider takes one track and the other takes the other track. After completing the first lap, the riders swap tracks.

**904.11 - RESULTS AND SCORING****904.11.01 - RACE FINAL RESULTS**

1st place: Battle for 1st ;	winner
2nd place: Battle for 1st ;	runner-up
3rd place: Battle for 3rd ;	winner
4th place: Battle for 3rd ;	runner-up
5th place: ROUND OF 8;	5th fastest
6th place: ROUND OF 8;	6th fastest
7th place: ROUND OF 8;	7th fastest
8th place: ROUND OF 8;	8th fastest
9th place: ROUND OF 14;	9th fastest
10th place: ROUND OF 14;	10th fastest
11th place: ROUND OF 14;	11th fastest
12th place: ROUND OF 14;	12th fastest
13th place: ROUND OF 14;	13th fastest
14th place: ROUND OF 14;	14th fastest

**904.11.02 - POINTS SCORING**

1st place: 25 points

2nd place: 20 points

3rd place: 16 points

4th place: 14 points

5th place: 12 points

6th place: 10 points

7th place: 8 points

8th place: 7 points

9th place: 6 points

10th place: 5 points

11th place: 4 points

12th place: 3 points

13th place: 2 points

14th place: 1 point

**904.11.03 - CHAMPIONSHIP WINNER**

Winner of the Championship is the rider with the most collected points from each particular round.

**905 - PROPER RIDING**

See article 310.

## **1000 - NATIONS CUP**

### **1000.01 NATIONS CUP RULES**

#### **1000.01.01 - GENERAL DESCRIPTION**

The Nations Team is composed of one male and one female athlete. In total, they compete for 10 laps where 5 laps are done by one athlete, the rest of the session is concluded by the other athlete. In lap Nr. 5 (when Nr. 5 is seen on the signalization board), athletes come to the shore where pass the Shut off key to their team mate.

#### **1000.01.02 - TEAM SWAP**

After passing lap Nr. 5, the rider makes his/her way through the designated corridor for the Team Swap. The rider has to make his/her way to the numbered stopping gate and stop the board within the stopping gate. The rider has to stop, leave the board inside the stopping gate and make his/her way to the shore to make the Shut off key swap. Riders stopping at the gate with particular number have to pass the Shut Off key to his/her team mate waiting by the same stand marked with number corresponding to the number of the stopping gate. Numbers of the stopping gate reflect the qualification position of the Team.

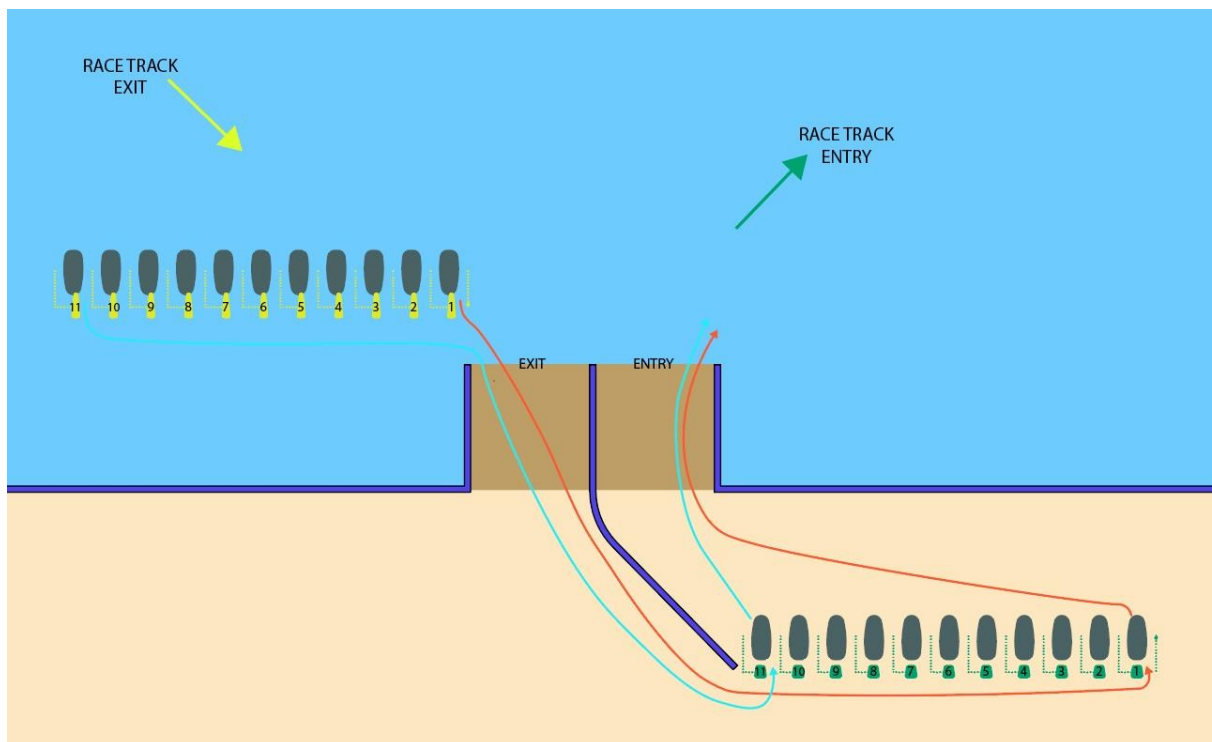

Picture 1 Swapping area illustration picture

### **1000.01.03 - SHUT OFF KEY SWAP**

- Every national team is able to enter heats and finals with only 1 (one) shut off key per team. Before every session, such shut off key is checked by the Technical commissioner in the waiting area. If the controlled shut off key is not approved, the team has to find a suitable shut off key.
- If the team is not able to find such shut off key, the team will not be allowed to start the session. Riders are not allowed to use any other shut off key than the one approved by the commissioner in the waiting area.
- Riders waiting for their team mate to conclude the Shut off key swap, must have their boards deactivated. Deactivation of the board will be checked by the Technical Scrutineer.

Any change of the shut off key after the check of the Technical Commissioner will lead to disqualification from the session.

#### **1000.01.03.01 - RIDER COMING OUT OF THE WATER**

- Rider arriving to the shore has to stop their board in the stopping gate and get out of the board and head to the shore.
- Rider coming to the shore has to slow down from the first buoy marking the water swapping corridor (the buoy announced at the riders briefing) and start riding in the displacement mode of cruising and keep constant speed. Riders are not allowed to significantly change speed. Since passing this buoy, rider is not allowed to gain/lose positions when riding until reaching of the stopping gate. The only exception is crash of the other rider.
- Displacement mode of cruising refers to a boat operating at a speed where it pushes through the water rather than riding on top of it. In this mode, the boat's hull creates a wave as it moves, and the speed is limited by the hull shape.
- Rider has to stop the board in the stopping gate, has to park the board in the marked area. When the board is placed the stopping area with its nose heading to the front side of the stopping area mark, rider can untie his/her leash and start making her/his way to the shore.
- Rider is allowed to provide any kind of help to his/her team mate such as – carrying the board to the water, putting the Shut off key on wrist.
- The only correctly put shut-off key is the one that is clicked and installed on the wrist.

#### **1000.01.03.02 - RIDER WAITING ON THE SHORE**

- Rider waiting on the shore is ready with the full equipment necessary for participation in the session, including leash.
- Rider is waiting for their his/her team mate to come to him/her to pass the Shut off key for its installation.
- As soon as the shut off key is properly installed on the wrist of the waiting rider, such rider can start moving his/her board to the water. It is up to the rider where the board is started.
- The rider waiting on the shore has to follow instructions of the correct racing track when launching the board to the water as per announcement on the riders briefing.
- Rider waiting on the shore concludes the remainder of the laps and ends the session with crossing the checkered flag.

#### **1000.01.04 - FIRST AND LAST BUOY OF THE TRACK**

- Defined and explained on the riders briefing

## 1000.01.05 - TECHNICAL REGULATIONS

### 1000.01.05.01 – SURFBOARDS

- The technical regulations are valid based on the categories that are appointed to participate in the Nations Cup. Announcement of the participating classes is stated in the Advance Program of the event.

### 1000.01.05.02 – SHUT OFF KEY

- Only the original jetsurf shut off key is allowed, part numbers: A000588, POA0095



*Picture 2 Illustration picture of the Shut-Off key*

## 1000.01.06 - PENALTIES

### 1000.01.06.01 – PENALTIES DURING THE SESSION (EXCLUDING THE TEAM SWAP)

- As per valid UIM regulations

### 1000.01.06.02 - PENALTIES DURING THE TEAM SWAP

- Not swapping team in the correct lap – disqualification (dsq)
- Not swapping the team at all – disqualification
- Gaining position in the swapping corridor – 60 seconds.
- Not stopping the board in the right designated (number) stopping area – 30 seconds
- Not parking the board in the right designated (number) stopping area – 30 seconds
- Not changing the cruising/riding mode into the displacement mode 30 seconds
- Not parking the board into the stopping area as 1.3.1. – 30 seconds
- Putting off the riding gear not as described in 1.3.1. – 30 seconds
- Inappropriate behaviour towards the other competitors during the team swap – based on the decision of the O.O.D.

## 1000.02 - SCORING FORMAT OF THE NATIONS CUP

### 1000.02.01 - QUALIFICATION

- Qualification is held in generally similar format of the singles but the pairs are made of athletes competing in the national team.
- Best qualifying laptime of male and female athletes are sum up which makes the qualifying laptime of the National Team.
- Team with the lowest qualifying laptime wins.

### 1000.02.02 - HEATS & FINALS

- Scoring of the heats and finals is identical for Single and Nations Cup competition.

**1000.03 - MEDAL CEREMONY AND STANDINGS****1000.03.01 - SINGLE & NATIONS CUP**

- Overall positions are determined by positions in the Finals.

**1000.04 - QUALIFICATION (ADDITION TO THE CURRENT UIM MOTOSURF RULEBOOK)****1000.04.01 - QUALIFICATION - SINGLES**

- Tbc by Motosurf Committee

**1000.04.02 - QUALIFICATIONS - NATIONS CUP**

- In case more two or more Teams finish the Qualificaiton with DNF, the ranking will be based on the standings in the singles qualifications in the following way:
  - o The positions of male and female representative will sum up. Example: Female rider qualified 6th, male riders qualified 7th -> total under for the team is  $6 + 7 = 13$ . Team with lower number is ranked higher.

## **APPENDIX 1 – DEFINITIONS AND SCHEMES**

FCS: stands for Fin Control System. FCS is one of the world's most renowned fins manufacturers. The fins have two tabs or plugs that are secured to the board using set screws.

EPA: The Environmental Protection Agency (EPA) is an independent agency of the United States government tasked with environmental protection matters.

Gliding mode: operational regime when the Personal Water Craft slides from displacement mode of sailing into gliding by getting enough speed to glide on the water causing minimal displacement of the craft.

Leash: A leg rope or surfboard leash is a urethane cord attached to the deck of a surfboard, on the control handle. It prevents the surfboard from being swept away by waves and stops runaway surfboards from hitting others on the race track.

AMSM: Association of Motorized Surfboards Manufacturers

© (2026) Copyright by UIM - Union Internationale Motonautique. All rights reserved. No part of this document/publication may be reproduced, distributed, or transmitted in any form or by any means without the prior written consent of the UIM, except for the non-commercial use within the scope of authority of the UIM and its affiliated members.

Picture 1 - Side fin toothed shapes:



Picture 2 – Main fin scheme:

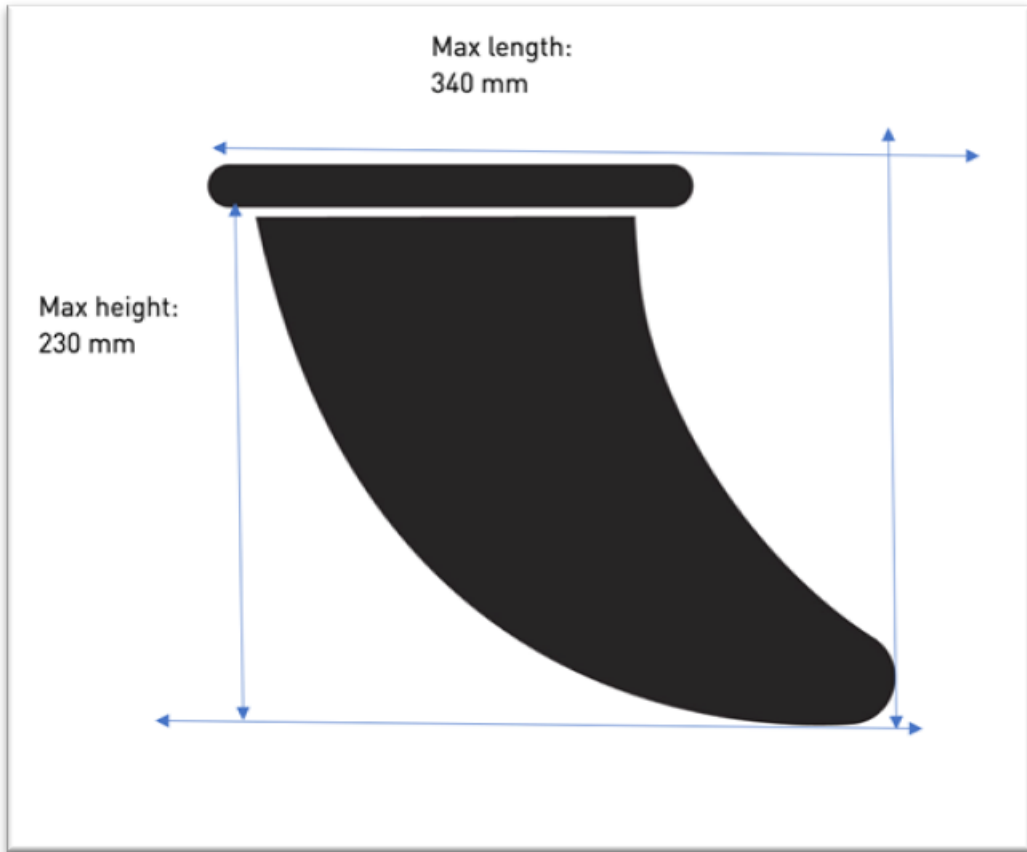

Picture 3 Starting block:



## APPENDIX 2 – JETSURF TITANIUM TECHNICAL SPECIFICATIONS



Homologation Form Complying with UIM Technical Regulations			
Type:	PWC		Homologation N°
Manufacturer:	MSR Engines s.r.o.		<b>MSR_H_B03</b>
Homologation valid as from:	17. FEB. 2026		

Applicable:	2021, JT-S1, JT-C1, JT-A1
-------------	---------------------------

PWC seen from top:

*This homologation applies exclusively to parts and assemblies manufactured and identified by the serial numbers listed below. All dimensions and parameters specified in this document are for verification purposes only. The approval of individual engines and assemblies is based solely on the manufacturer's designation and serial numbering by MSR engines s.r.o.*

Homologation Form Complying with UIM Technical Regulations		
Type:	PWC	Homologation N° <b>MSR_H_B03</b>
Manufacturer:	MSR Engines s.r.o.	
Homologation valid as from:	17. FEB. 2026	

1. Engine: MSR NG100 DFi Ti A002271, A003635

a. Photography of engine:

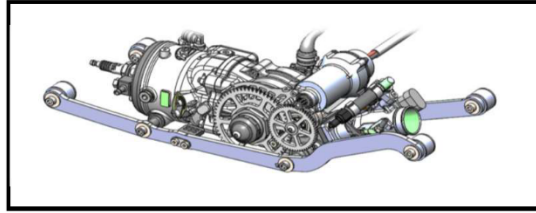

b. Main drawings of engine:

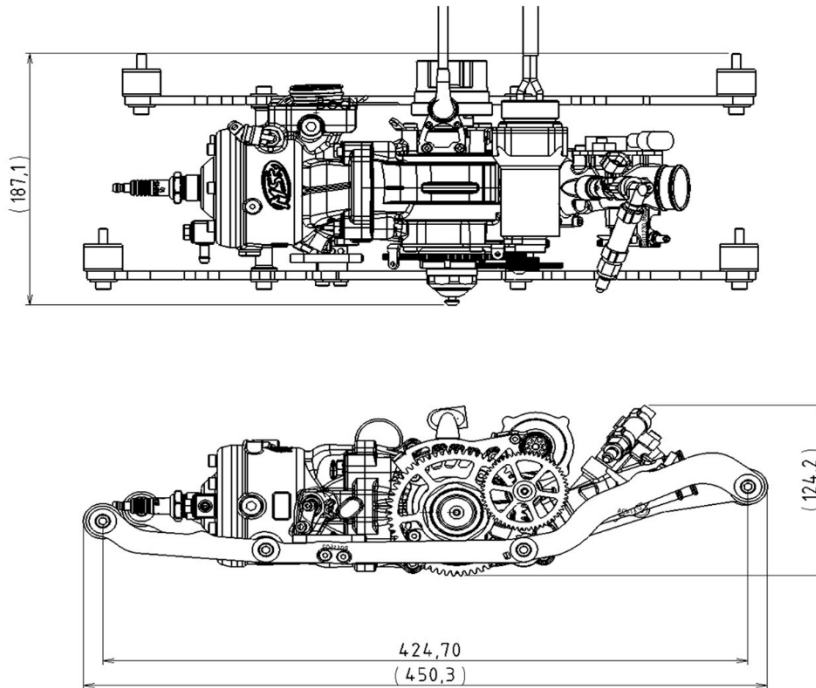

Homologation Form Complying with UIM Technical Regulations		
Type:	PWC	Homologation N°
Manufacturer:	MSR Engines s.r.o.	MSR_H_B03
Homologation valid as from:	17. FEB. 2026	

- 1.1 Cycle: Two stroke
- 1.2 Engine capacity: 97,2 [cm<sup>3</sup>]
- 1.3 Cylinder block material: Aluminium
- 1.4 Sleeves:  YES  No
- 1.5 Bore: 50 [mm] Tolerance: +/- 2%
- 1.6 Stroke: 49,5 [mm] Tolerance: +/- 2%
- 1.7 Timing: 0,12 [mm] Tolerance: +/- 0,04 mm

*\*The Timing value is the distance offset of the piston top from the TDC position.*

- a. Method of measurement: Calibrated tool N.: POA1928
- b. Photography of tool:



Homologation Form Complying with UIM Technical Regulations		
Type:	PWC	Homologation N° <b>MSR_H_B03</b>
Manufacturer:	MSR Engines s.r.o.	
Homologation valid as from:	17. FEB. 2026	

## 1.8.1 Exhaust port D25

- a. Exhaust engine port dimension: 25 [mm] Tolerance: +/- 2%

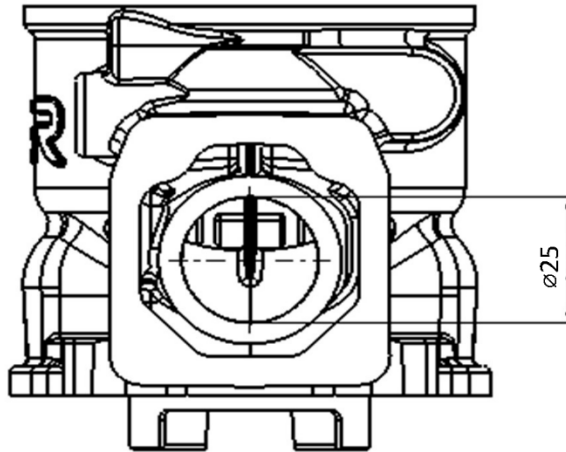

- b. Exhaust flange port dimension: 25 [mm] Tolerance: +/- 2%

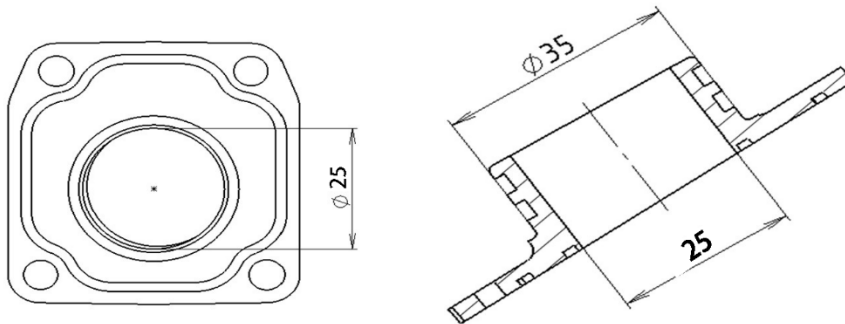

Homologation Form Complying with UIM Technical Regulations		
Type:	PWC	Homologation N° <b>MSR_H_B03</b>
Manufacturer:	MSR Engines s.r.o.	
Homologation valid as from:	17. FEB. 2026	

## 1.8.2 Exhaust port D27

- a. Exhaust engine port dimension: 27 [mm] Tolerance: +/- 2%

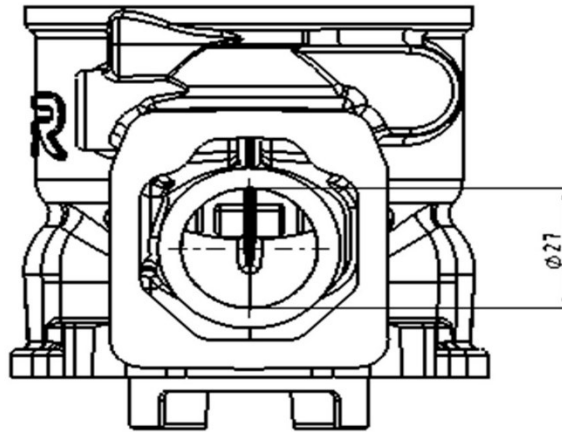

- b. Exhaust flange port dimension: 27 [mm] Tolerance: +/- 2%

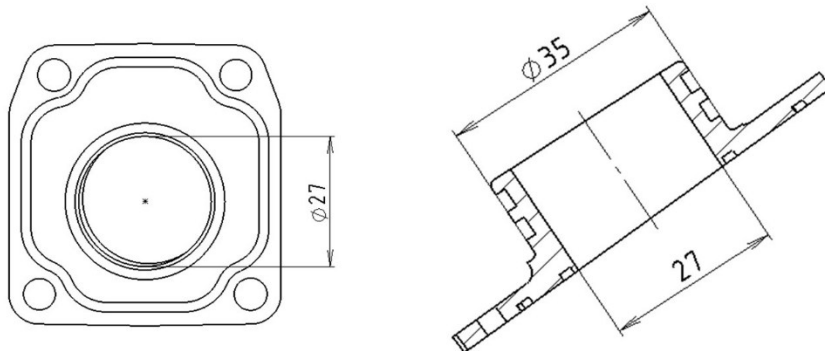

Homologation Form Complying with UIM Technical Regulations		
Type:	PWC	Homologation N° <b>MSR_H_B03</b>
Manufacturer:	MSR Engines s.r.o.	
Homologation valid as from:	17. FEB. 2026	

## 1.9 Intake port

- a. Intake engine port dimension:
- |    |      |      |                   |
|----|------|------|-------------------|
| 1. | 49   | [mm] | Tolerance: +/- 1% |
| 2. | 27,5 | [mm] | Tolerance: +/- 2% |

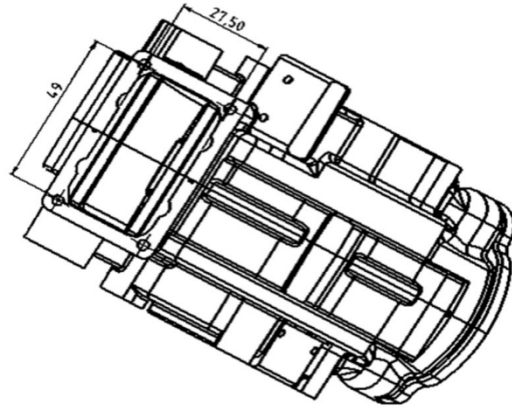

- a. Drawing of reed valve: Tolerance: +/- 2%

*\*Tolerances apply to dimensions without specified deviation on the drawing.*

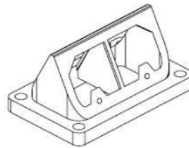
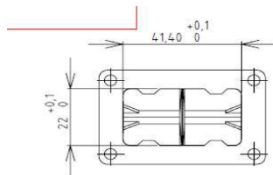

Číslo	Číslo	Revize	Název	Množství	Material
1	P004698	00	Vaniliová klac	1	Material - není určen
2	P004699	00	Jazyček	2	Thornel Mat VMA
3	P004700	00	Přiložka jazyčku	2	Material - není určen
4	P011764	00	Šroub DIN 7049 2,2x6,5	4	

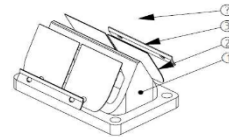

Homologation Form Complying with UIM Technical Regulations		
Type:	PWC	Homologation N° <b>MSR_H_B03</b>
Manufacturer:	MSR Engines s.r.o.	
Homologation valid as from:	17. FEB. 2026	

## 1.10 Throttle body and injector

a. Throttle body inlet dimension: 22 [mm] Tolerance: +/- 2,5%

Method of measurement: Calibrated tool N.: MSR\_ST\_A\_01

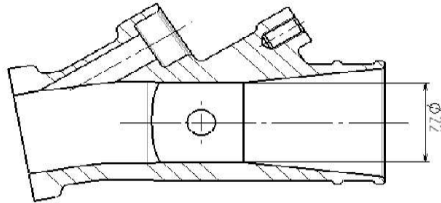

b. Injector type: BOSCH 0 280 158 251  
P009523

c. Injector photography:

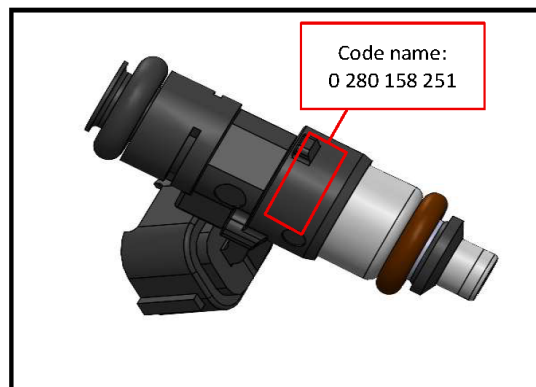

Homologation Form Complying with UIM Technical Regulations		
Type:	PWC	Homologation N° <b>MSR_H_B03</b>
Manufacturer:	MSR Engines s.r.o.	
Homologation valid as from:	17. FEB. 2026	

## 1.11 Connection rod

## a. Connection rod photography:



b. Interior diameter of the big end (without shell bearings): 22 [mm] Tolerance: +/- 0,5%

c. Length between the axes 91 [mm] Tolerance: +/- 0,5%

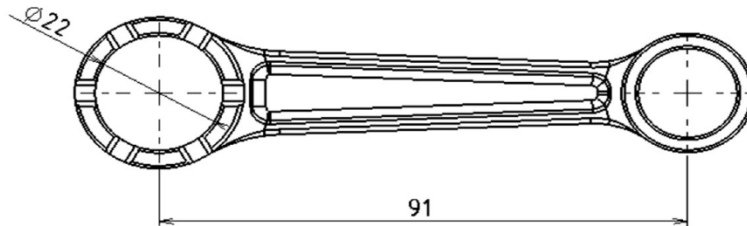

Homologation Form Complying with UIM Technical Regulations		
Type:	PWC	Homologation N° <b>MSR_H_B03</b>
Manufacturer:	MSR Engines s.r.o.	
Homologation valid as from:	17. FEB. 2026	

## 1.12 Piston

## a. Photography of piston:



b. Distance from gudgeon pin center line to highest point of piston crown      22,44      [mm]      Tolerance:      +/- 1%

c. Distance Maximum length of piston:      52,74      [mm]      Tolerance:      +/- 1%

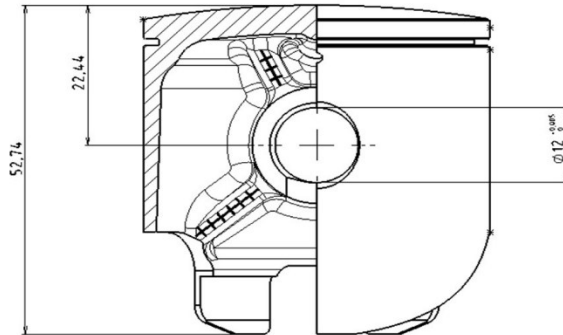

Homologation Form Complying with UIM Technical Regulations		
Type:	PWC	Homologation N°
Manufacturer:	MSR Engines s.r.o.	MSR_H_B03
Homologation valid as from:	17. FEB. 2026	

- f. Distance (+/-) between the top of the piston at TDC and the gasket plane of the cylinder block: Upper value: - [mm]  
Lower value: 0,8 [mm]
- g. Method of measurement: Calibrated tool N.: MSR\_ST\_A\_02

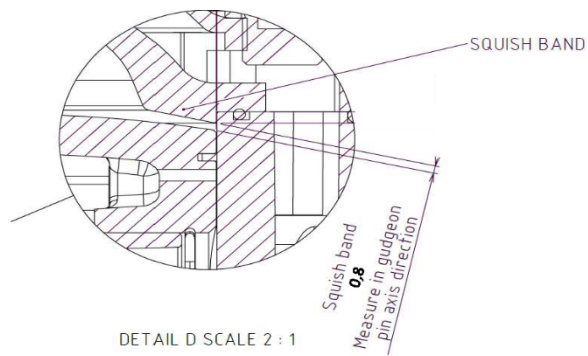

Homologation Form Complying with UIM Technical Regulations		
Type:	PWC	Homologation N° <b>MSR_H_B03</b>
Manufacturer:	MSR Engines s.r.o.	
Homologation valid as from:	17. FEB. 2026	

- 1.13 Crank shaft assembly: A000040
- a. Minimum weight: 1195 [g] Tolerance: +/- 5%
- b. Photography of crankshaft:

*\*Weighing of the assembly as shown in the drawing; the shaft retaining key is included.*

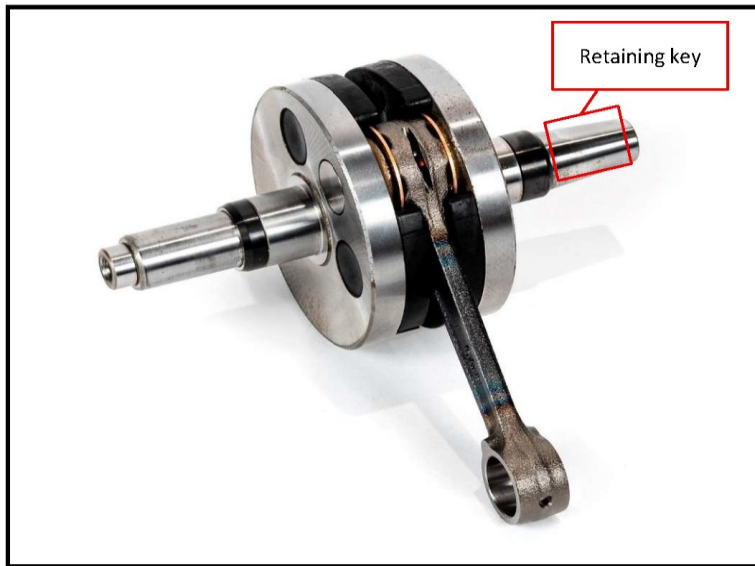

Homologation Form Complying with UIM Technical Regulations		
Type:	PWC	Homologation N° <b>MSR_H_B03</b>
Manufacturer:	MSR Engines s.r.o.	
Homologation valid as from:	17. FEB. 2026	

- 1.14 Crank shaft assembly: A003403
- a. Minimum weight: 1195 [g] Tolerance: +/- 5%
- b. Photography of crankshaft:

*\*Weighing of the assembly as shown in the drawing; the shaft retaining key is included.*

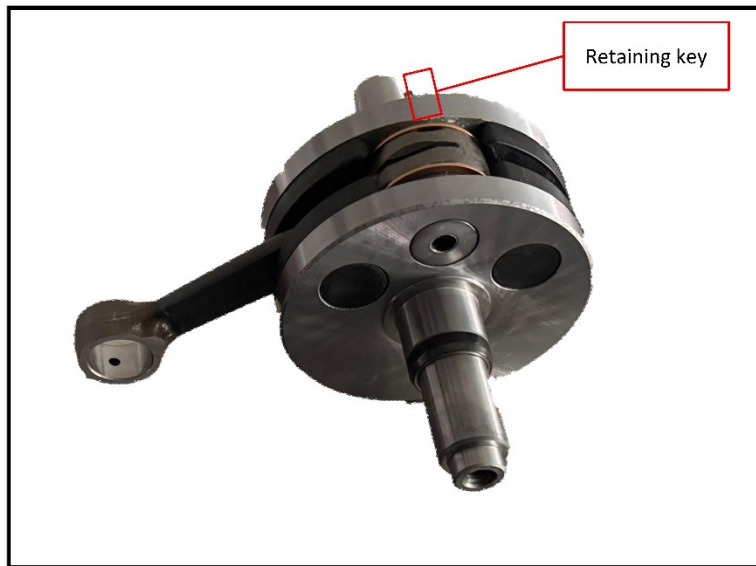

Homologation Form Complying with UIM Technical Regulations		
Type:	PWC	Homologation N° <b>MSR_H_B03</b>
Manufacturer:	MSR Engines s.r.o.	
Homologation valid as from:	17. FEB. 2026	

2. Exhaust system: A003614, A000944, POA3876, P007263
- a. Photography of exhaust assembly:



*\*The use of the silencer without the non-return valve (ball) is permitted.*

Homologation Form Complying with UIM Technical Regulations		
Type:	PWC	Homologation N° <b>MSR_H_B03</b>
Manufacturer:	MSR Engines s.r.o.	
Homologation valid as from:	17. FEB. 2026	

## 2.1 Resonator

a. Resonator in/ex dimensions:	1.	27	[mm]	Tolerance: +/- 2%
	2.	35,5	[mm]	Tolerance: +/- 1,5%
	3.	15,4	[mm]	Tolerance: +/- 2%
	4.	29	[mm]	Tolerance: +/- 1,5%

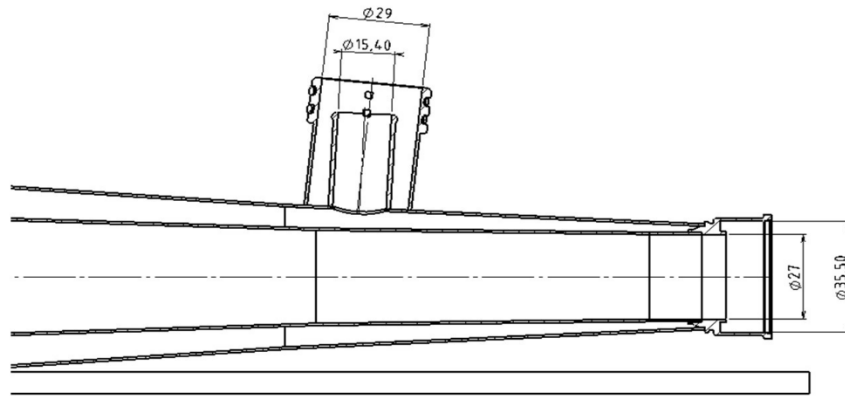

## 2.2 CFRP knee

a. CFRP knee in/ex dimensions:	1.	37	[mm]	Tolerance: +/- 5%
	2.	35	[mm]	Tolerance: +/- 5%

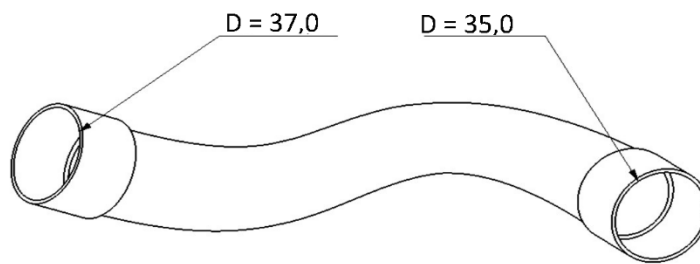

Homologation Form Complying with UIM Technical Regulations		
Type:	PWC	Homologation N° <b>MSR_H_B03</b>
Manufacturer:	MSR Engines s.r.o.	
Homologation valid as from:	17. FEB. 2026	

## 2.3 Silencer

- a. Silencer in/ex dimensions:
- |    |      |      |                     |
|----|------|------|---------------------|
| 1. | 20   | [mm] | Tolerance: +/- 1,5% |
| 2. | 30,4 | [mm] | Tolerance: +/- 2%   |



Homologation Form Complying with UIM Technical Regulations		
Type:	PWC	Homologation N° <b>MSR_H_B03</b>
Manufacturer:	MSR Engines s.r.o.	
Homologation valid as from:	17. FEB. 2026	

## 2.4 Cooling nozzle

## a. Photography of cooling nozzle:



- b. Nozzle inlet diameter:
- |    |           |      |                       |
|----|-----------|------|-----------------------|
| 1. | 2,3       | [mm] | Tolerance: +/- 0,1 mm |
| 2. | 2,3       | [mm] | Tolerance: +/- 0,1 mm |
| 3. | 1,5 - 2,3 | [mm] | Tolerance: +/- 0,1 mm |
| 4. | 2,3       | [mm] | Tolerance: +/- 0,1 mm |

- g. Method of measurement: Calibrated tool N.: MSR\_ST\_A\_03, MSR\_ST\_A\_04

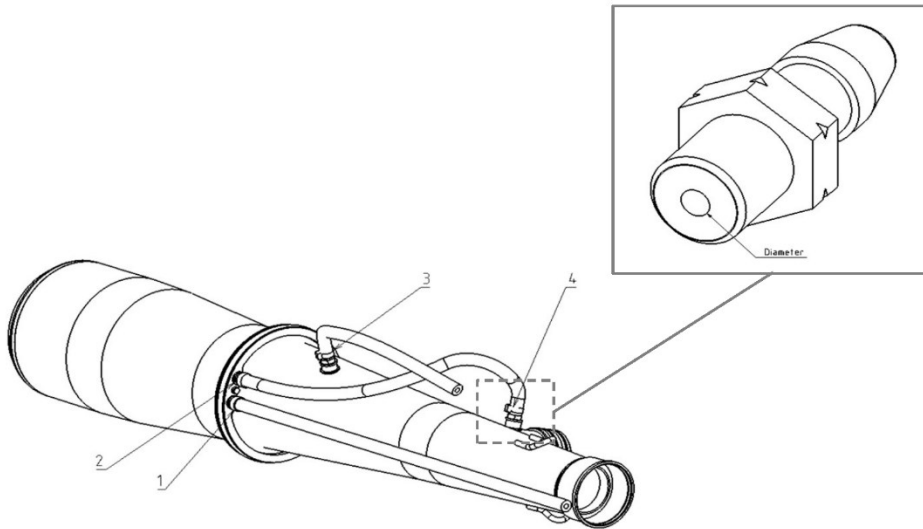

Homologation Form Complying with UIM Technical Regulations		
Type:	PWC	Homologation N° <b>MSR_H_B03</b>
Manufacturer:	MSR Engines s.r.o.	
Homologation valid as from:	17. FEB. 2026	

3. Jetpump Titan Stock A002293

a. Jetpump dimensions:	1.	207,5	[mm]	Tolerance: +/- 2%
	2.	140	[mm]	Tolerance: +/- 1,5%
	3.	120	[mm]	Tolerance: +/- 2%
	4.	8	[mm]	Tolerance: +/- 2%

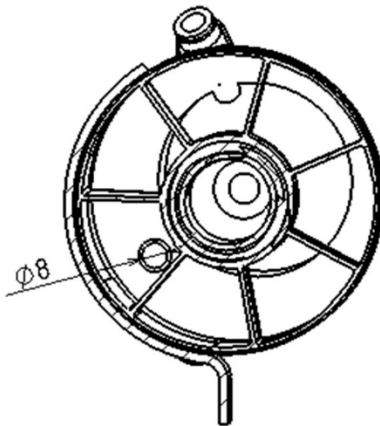
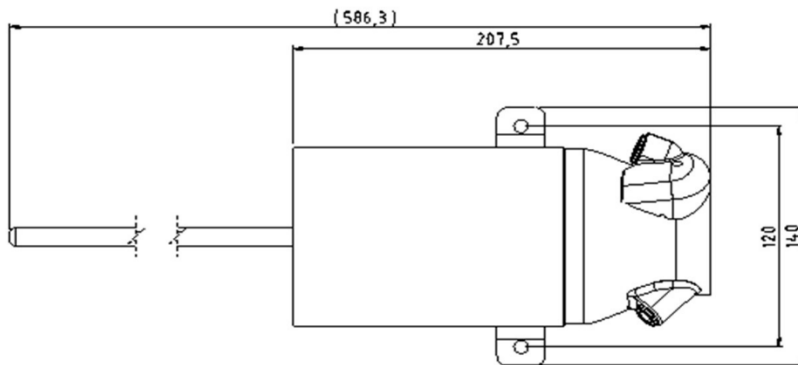

Homologation Form Complying with UIM Technical Regulations		
Type:	PWC	Homologation N° <b>MSR_H_B03</b>
Manufacturer:	MSR Engines s.r.o.	
Homologation valid as from:	17. FEB. 2026	

## 3.1 Stator Titan Stock

- a. Stator dimensions:
- |    |      |      |            |        |
|----|------|------|------------|--------|
| 1. | 92.8 | [mm] | Tolerance: | +/- 1% |
| 2. | 97   | [mm] | Tolerance: | +/- 1% |
| 3. | 58.8 | [mm] | Tolerance: | +/- 1% |
- b. Method of measurement:                      Calibrated tool N.: MSR\_ST\_A\_06

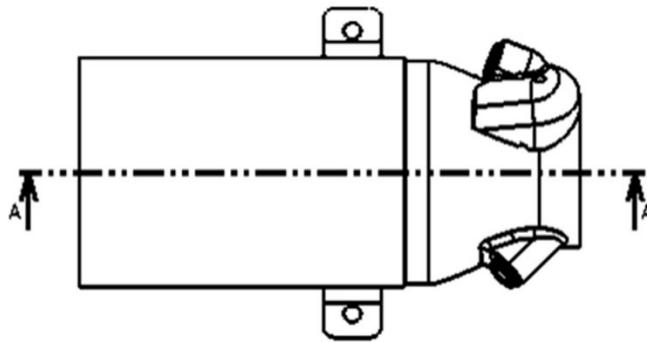
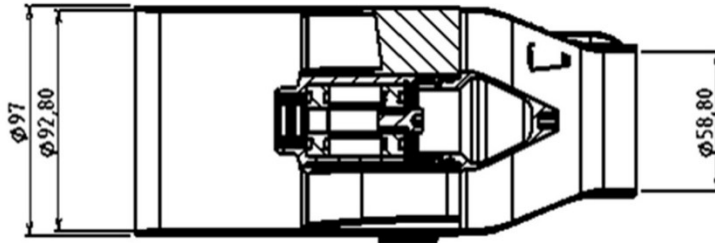

Homologation Form Complying with UIM Technical Regulations		
Type:	PWC	Homologation N° <b>MSR_H_B03</b>
Manufacturer:	MSR Engines s.r.o.	
Homologation valid as from:	17. FEB. 2026	

## 3.2 Propeller 15-19

- a. Outer shape: R46 [mm] Tolerance: +/- 1%
- b. Method of measurement: Calibrated tool N.: MSR\_ST\_A\_07
- c. Rotor length: 35,75 [mm] Tolerance: +/- 1%

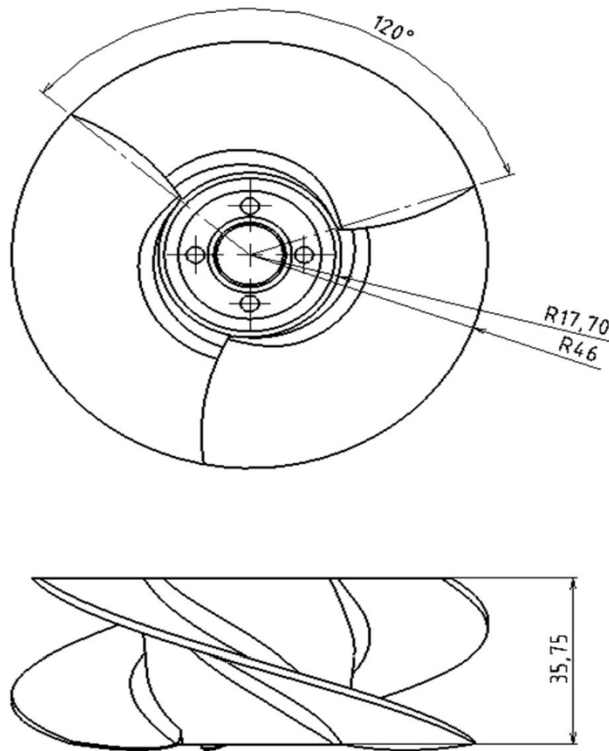

Homologation Form Complying with UIM Technical Regulations		
Type:	PWC	Homologation N° <b>MSR_H_B03</b>
Manufacturer:	MSR Engines s.r.o.	
Homologation valid as from:	17. FEB. 2026	

## 4. Electronics

4.1 Main cable harness: A002341

a. Photography of main cable harness:



4.2 Starter cable harness: A000456

b. Photography of starter cable harness:



Homologation Form Complying with UIM Technical Regulations		
Type:	PWC	Homologation N° <b>MSR_H_B03</b>
Manufacturer:	MSR Engines s.r.o.	
Homologation valid as from:	17. FEB. 2026	

4.3 ICU: A001058

a. Photography of ICU:



4.4 Ignition spark plug

a. Type of ignition spark plug: NGK BPR7HS 6422

b. Photography of ignition spark plug:



## APPENDIX 3 – JETSURF RACE DFI TECHNICAL SPECIFICATIONS



Homologation Form Complying with UIM Technical Regulations			
Type:	PWC		Homologation N°
Manufacturer:	MSR Engines s.r.o.		<b>MSR_H_A03</b>
Homologation valid as from:	17. FEB. 2026		

Applicable:	2021, JR-A1, JR-B1, JR-C1, JR-D1
-------------	----------------------------------

PWC seen from top:

*This homologation applies exclusively to parts and assemblies manufactured and identified by the serial numbers listed below. All dimensions and parameters specified in this document are for verification purposes only. The approval of individual engines and assemblies is based solely on the manufacturer's designation and serial numbering by MSR engines s.r.o.*

Homologation Form Complying with UIM Technical Regulations		
Type:	PWC	Homologation N° <b>MSR_H_A03</b>
Manufacturer:	MSR Engines s.r.o.	
Homologation valid as from:	17. FEB. 2026	

1. Engine: MSR NG100 DFi A 001090

a. Photography of engine:



b. Main drawings of engine:

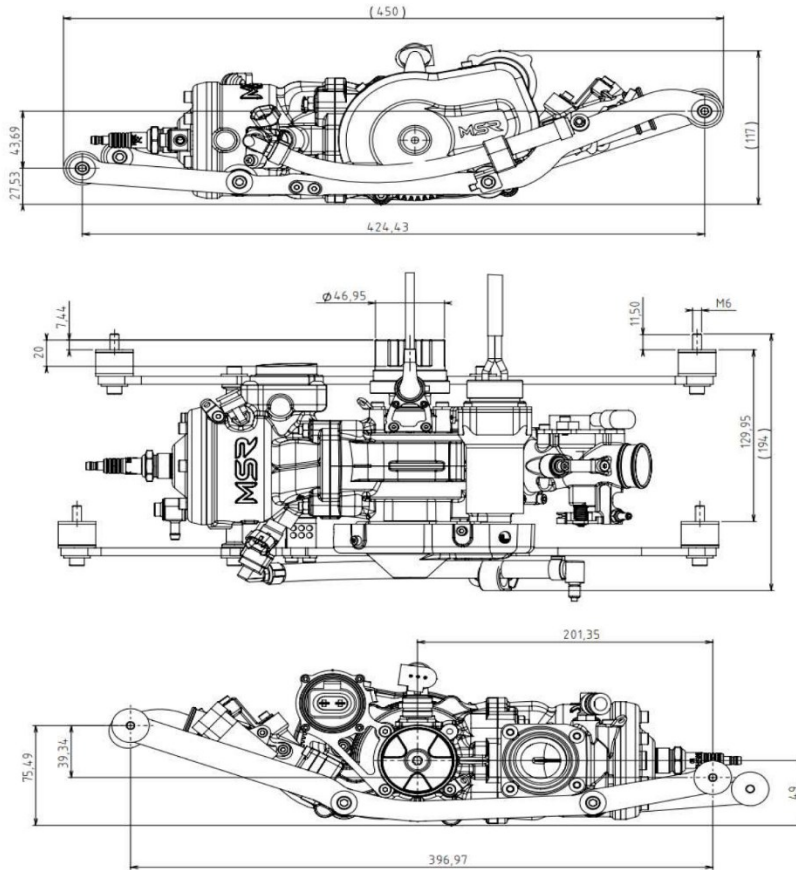

Homologation Form Complying with UIM Technical Regulations		
Type:	PWC	Homologation N° <b>MSR_H_A03</b>
Manufacturer:	MSR Engines s.r.o.	
Homologation valid as from:	17. FEB. 2026	

- 1.1 Cycle: Two stroke
- 1.2 Engine capacity: 97,2 [cm<sup>3</sup>]
- 1.3 Cylinder block material: Aluminium
- 1.4 Sleeves:  YES  No
- 1.5 Bore: 50 [mm] Tolerance: +/- 2%
- 1.6 Stroke: 49,5 [mm] Tolerance: +/- 2%
- 1.7 Timing: 0,12 [mm] Tolerance: +/- 0,04 mm

*\*The Timing value is the distance offset of the piston top from the TDC position.*

- a. Method of measurement: Calibrated tool N.: POA1928
- b. Photography of tool:



Homologation Form Complying with UIM Technical Regulations		
Type:	PWC	Homologation N° <b>MSR_H_A03</b>
Manufacturer:	MSR Engines s.r.o.	
Homologation valid as from:	17. FEB. 2026	

## 1.8 Exhaust port

- a. Exhaust engine port dimension: 25 [mm] Tolerance: +/- 2%

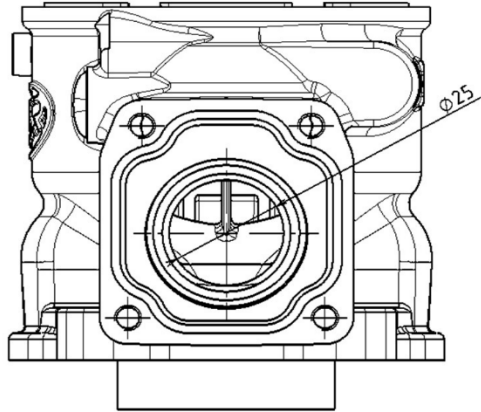

- b. Exhaust flange port dimension:
- |    |    |      |                     |
|----|----|------|---------------------|
| 1. | 25 | [mm] | Tolerance: +/- 2%   |
| 2. | 35 | [mm] | Tolerance: +/- 1,5% |
| 3. | 14 | [mm] | Tolerance: +/- 2%   |

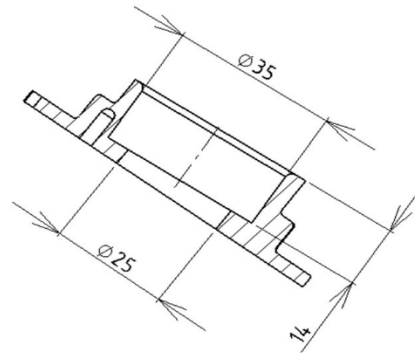
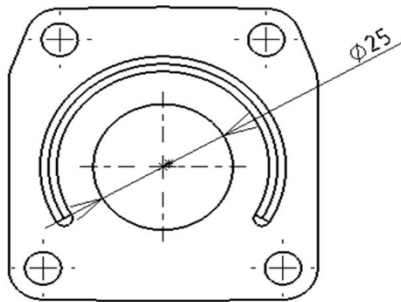

Homologation Form Complying with UIM Technical Regulations		
Type:	PWC	Homologation N° <b>MSR_H_A03</b>
Manufacturer:	MSR Engines s.r.o.	
Homologation valid as from:	17. FEB. 2026	

1.9 Intake port

- a. Intake engine port dimension:
- |    |      |      |                   |
|----|------|------|-------------------|
| 1. | 49   | [mm] | Tolerance: +/- 1% |
| 2. | 27,5 | [mm] | Tolerance: +/- 2% |

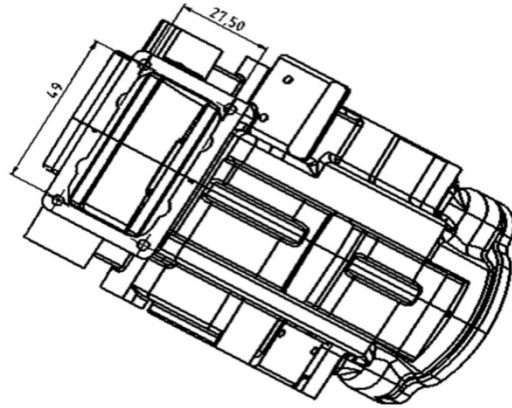

- a. Drawing of reed valve: Tolerance: +/- 2%

*\*Tolerances apply to dimensions without specified deviation on the drawing.*

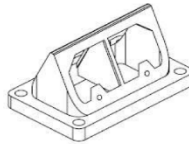
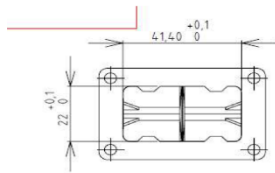

Číslo	Číslo	Revize	Název	Množství	Material
1	P004698	00	Vaniliová klac	1	Material - není určen
2	P004699	00	Jazyček	2	Thornel Mat VMA
3	P004700	00	Přiložka jazyčku	2	Material - není určen
4	P011764	00	Šroub DIN 7049 2,2x6,5	4	

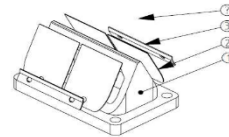

Homologation Form Complying with UIM Technical Regulations		
Type:	PWC	Homologation N° <b>MSR_H_A03</b>
Manufacturer:	MSR Engines s.r.o.	
Homologation valid as from:	17. FEB. 2026	

## 1.10 Throttle body and injector

a. Throttle body inlet dimension: 22 [mm] Tolerance: +/- 2,5%

Method of measurement: Calibrated tool N.: MSR\_ST\_A\_01

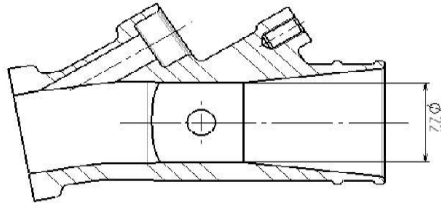

b. Injector type: BOSCH 0 280 158 251  
P009523

c. Injector photography:

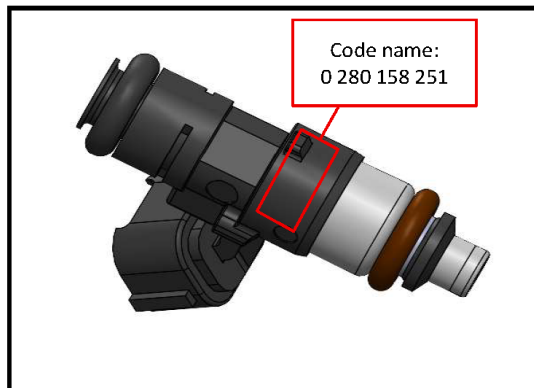

Homologation Form Complying with UIM Technical Regulations		
Type:	PWC	Homologation N° <b>MSR_H_A03</b>
Manufacturer:	MSR Engines s.r.o.	
Homologation valid as from:	17. FEB. 2026	

1.11 Connection rod

a. Connection rod photography:



b. Interior diameter of the big end (without shell bearings): 22 [mm] Tolerance: +/- 0,5%

c. Length between the axes 91 [mm] Tolerance: +/- 0,5%

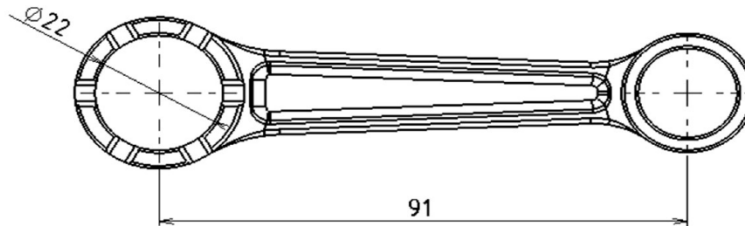

Homologation Form Complying with UIM Technical Regulations		
Type:	PWC	Homologation N° <b>MSR_H_A03</b>
Manufacturer:	MSR Engines s.r.o.	
Homologation valid as from:	17. FEB. 2026	

## 1.12 Piston

## a. Photography of piston:



b. Distance from gudgeon pin center line to highest point of piston crown      22,44      [mm]      Tolerance:      +/- 1%

c. Distance Maximum length of piston:      52,74      [mm]      Tolerance:      +/- 1%

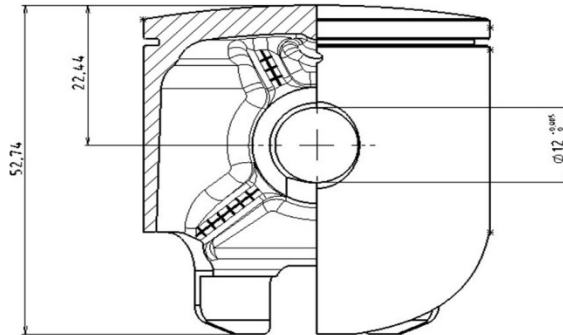

Homologation Form Complying with UIM Technical Regulations		
Type:	PWC	Homologation N°
Manufacturer:	MSR Engines s.r.o.	<b>MSR_H_A03</b>
Homologation valid as from:	17. FEB. 2026	

f. Distance (+/-) between the top of the piston at TDC and the gasket plane of the cylinder block:      Upper value: -      [mm]  
 Lower value: 0,8      [mm]

g. Method of measurement:      Calibrated tool N.: MSR\_ST\_A\_02

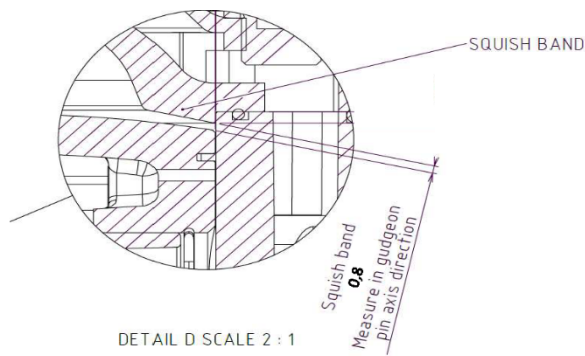

Homologation Form Complying with UIM Technical Regulations		
Type:	PWC	Homologation N° <b>MSR_H_A03</b>
Manufacturer:	MSR Engines s.r.o.	
Homologation valid as from:	17. FEB. 2026	

1.13 Crank shaft assembly: A000040

- a. Minimum weight: 1195 [g] Tolerance: +/- 5%
- b. Photography of crankshaft:

*\*Weighing of the assembly as shown in the drawing; the shaft retaining key is included.*

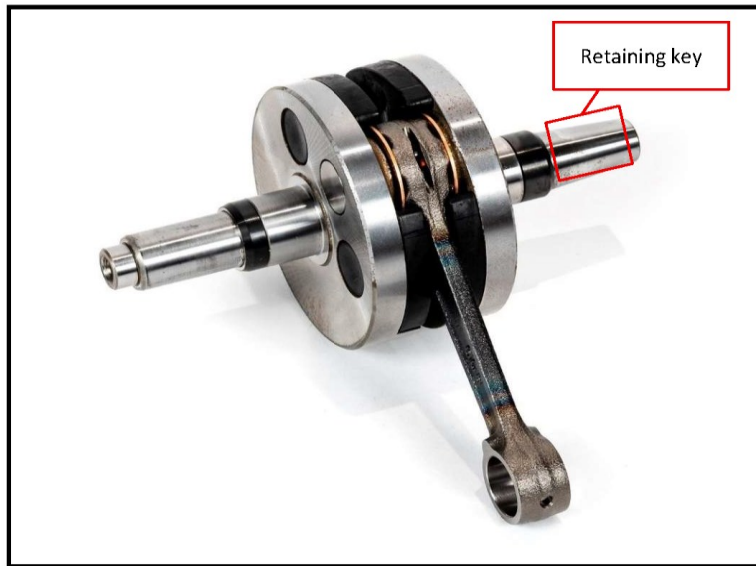

Homologation Form Complying with UIM Technical Regulations		
Type:	PWC	Homologation N° <b>MSR_H_A03</b>
Manufacturer:	MSR Engines s.r.o.	
Homologation valid as from:	17. FEB. 2026	

- 1.14 Crank shaft assembly: A003403
- a. Minimum weight: 1195 [g] Tolerance: +/- 5%
- b. Photography of crankshaft:

*\*Weighing of the assembly as shown in the drawing; the shaft retaining key is included.*

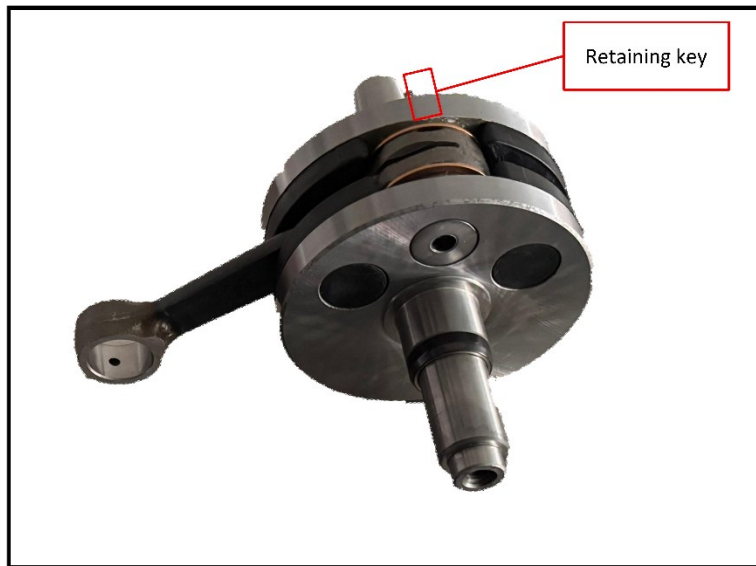

Homologation Form Complying with UIM Technical Regulations		
Type:	PWC	Homologation N° <b>MSR_H_A03</b>
Manufacturer:	MSR Engines s.r.o.	
Homologation valid as from:	17. FEB. 2026	

2. Exhaust system: A004200, A003627, A003269, A000064, A001118
- a. Photography of exhaust assembly:



*\*The use of the silencer without the non-return valve (ball) is permitted.*

Homologation Form Complying with UIM Technical Regulations		
Type:	PWC	Homologation N° <b>MSR_H_A03</b>
Manufacturer:	MSR Engines s.r.o.	
Homologation valid as from:	17. FEB. 2026	

## 2.1 Resonator

- a. Resonator in/ex dimensions:
- |    |      |      |            |          |
|----|------|------|------------|----------|
| 1. | 26   | [mm] | Tolerance: | +/- 2%   |
| 2. | 15,6 | [mm] | Tolerance: | +/- 1,5% |

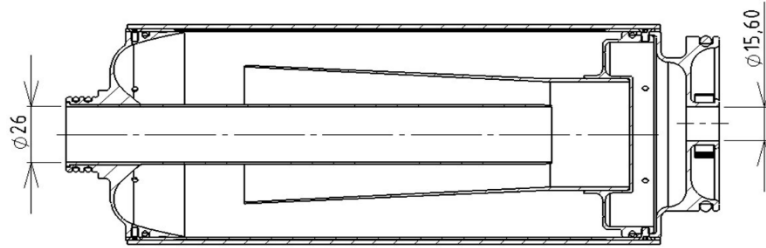

## 2.2 Silencer

- a. Silencer in/ex dimensions:
- |    |      |      |            |        |
|----|------|------|------------|--------|
| 1. | 20   | [mm] | Tolerance: | +/- 2% |
| 2. | 15,6 | [mm] | Tolerance: | +/- 2% |
| 3. | 14   | [mm] | Tolerance: | +/- 2% |

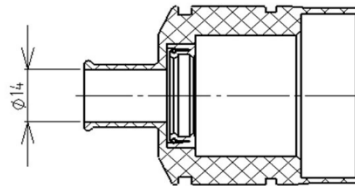
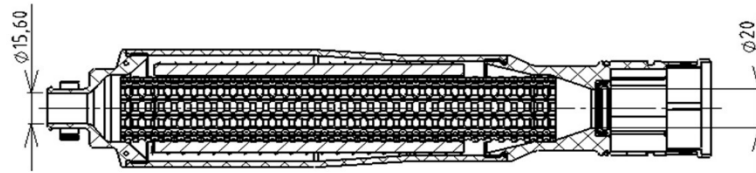

Homologation Form Complying with UIM Technical Regulations		
Type:	PWC	Homologation N° <b>MSR_H_A03</b>
Manufacturer:	MSR Engines s.r.o.	
Homologation valid as from:	17. FEB. 2026	

2.3 Cooling nozzle

a. Photography of cooling nozzle:



b. Nozzle inlet diameter: 1,5 - 2,3 [mm] Tolerance: +/- 0,1 mm

g. Method of measurement: Calibrated tool N.: MSR\_ST\_A\_03, MSR\_ST\_A\_04

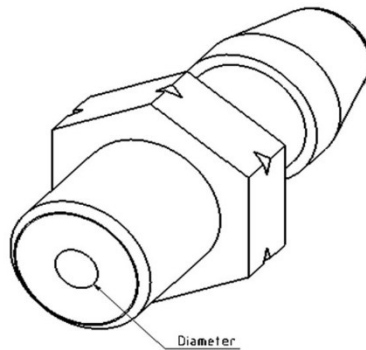

Homologation Form Complying with UIM Technical Regulations		
Type:	PWC	Homologation N° <b>MSR_H_A03</b>
Manufacturer:	MSR Engines s.r.o.	
Homologation valid as from:	17. FEB. 2026	

3. Jetpump MSR DFI A001423

- a. Jetpump dimensions:
- |    |       |      |                     |
|----|-------|------|---------------------|
| 1. | 187,5 | [mm] | Tolerance: +/- 2%   |
| 2. | 140   | [mm] | Tolerance: +/- 1,5% |
| 3. | 120   | [mm] | Tolerance: +/- 2%   |
| 4. | 8     | [mm] | Tolerance: +/- 2%   |

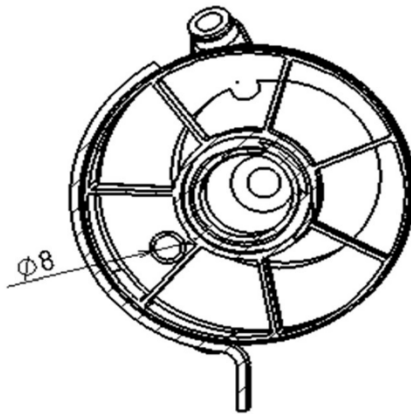
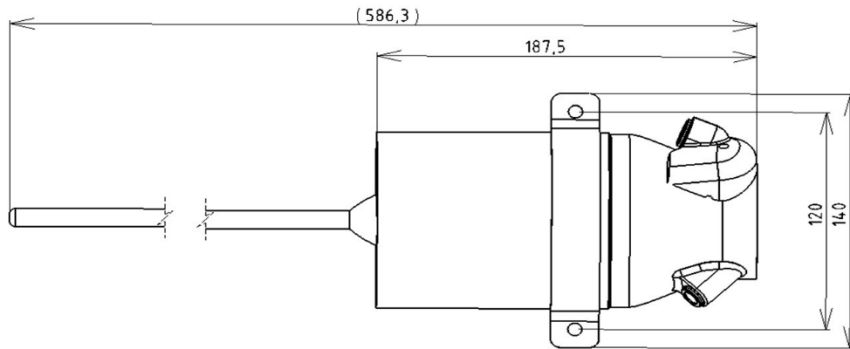

Homologation Form Complying with UIM Technical Regulations		
Type:	PWC	Homologation N° <b>MSR_H_A03</b>
Manufacturer:	MSR Engines s.r.o.	
Homologation valid as from:	17. FEB. 2026	

## 3.1 Jetpump stator DF1

- a. Stator dimensions:
- |    |      |      |            |        |
|----|------|------|------------|--------|
| 1. | 92.8 | [mm] | Tolerance: | +/- 1% |
| 2. | 97   | [mm] | Tolerance: | +/- 1% |
| 3. | 61,6 | [mm] | Tolerance: | +/- 1% |
- b. Method of measurement:                      Calibrated tool N.: MSR\_ST\_A\_05

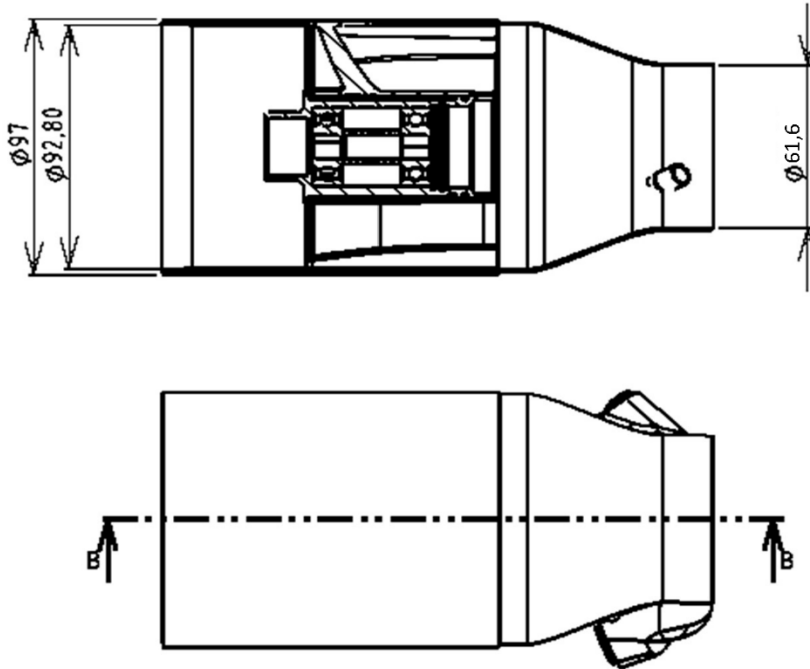

Homologation Form Complying with UIM Technical Regulations		
Type:	PWC	Homologation N° <b>MSR_H_A03</b>
Manufacturer:	MSR Engines s.r.o.	
Homologation valid as from:	17. FEB. 2026	

## 3.2 Propeller 15-19

- a. Outer shape: R46 [mm] Tolerance: +/- 1%
- b. Method of measurement: Calibrated tool N.: MSR\_ST\_A\_07
- c. Rotor length: 35,75 [mm] Tolerance: +/- 1%

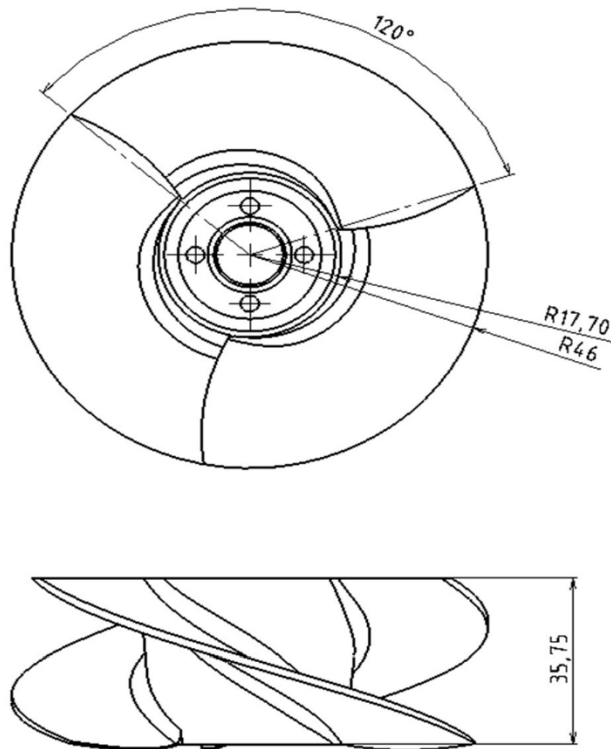

Homologation Form Complying with UIM Technical Regulations		
Type:	PWC	Homologation N° <b>MSR_H_A03</b>
Manufacturer:	MSR Engines s.r.o.	
Homologation valid as from:	17. FEB. 2026	

## 4. Electronics

4.1 Main cable harness: A003735, A001271

a. Photography of main cable harness:



4.2 Starter cable harness: A000456

b. Photography of starter cable harness:



Homologation Form Complying with UIM Technical Regulations		
Type:	PWC	Homologation N° <b>MSR_H_A03</b>
Manufacturer:	MSR Engines s.r.o.	
Homologation valid as from:	17. FEB. 2026	

4.3 ICU: A001058

a. Photography of ICU:



4.4 Ignition spark plug

a. Type of ignition spark plug: NGK BPR7HS 6422

b. Photography of ignition spark plug:





# CODE OF ETHICS 2026

## TABLE OF CONTENTS

<b>CODE OF ETHICS</b> .....	<b>114</b>
1. PREAMBLE.....	116
THE ETHICAL PILLARS OF THE UIM .....	116
1.1 Equality .....	116
1.2 Fair Play .....	116
1.3 Respect.....	116
1.4 Integrity .....	117
1.5 Environment.....	118
2. GENERAL CONDUCT REGULATIONS .....	119
2.1 Basic rules.....	119
2.2 Representational duties .....	119
2.3 Conduct towards government and private organizations.....	119
2.4 Ban on discrimination.....	119
2.5 Eligibility and dismissal.....	119
2.6 Protection of personal rights.....	119
2.7 Loyalty and confidentiality .....	119
3. PROCEEDINGS .....	120
4. ENFORCEMENT .....	120

## 1. PREAMBLE

The UIM is committed to the highest standards of conduct in sport Administration and Competition. To meet this commitment, the UIM has developed a Code of Ethics to express the core values of both the organization and the sport of Powerboating. Such values and ethics underpin the UIM's policies, procedures and rules. Observance of the Code is vital to the integrity of Powerboating. The UIM Code of Ethics is inspired to the ethical principles of the Olympic Movement of which the UIM is member.

The UIM Code of Ethics comprises five pillars. It imposes obligations in terms of respect and responsibility to competitors, teams, promoters, participants and all other UIM accredited Persons.

This Code shall apply to all UIM members (either national federation or any other similar affiliated entity), UIM staff, Persons elected or appointed to any position within the organization of the UIM or the Continental Organizations, and other individuals engaged in UIM activities, including Drivers, competitors, team managers, team members etc. (collectively referred to herein as "Participants"). It shall also apply to consultants and contractually-connected Persons/firms, including those representing or serving UIM.

Unless otherwise specified, infringements are punishable regardless of whether they have been committed deliberately or negligently.

Acts amounting to attempted infringements are also punishable. In the case of acts amounting to attempted infringements, the Executive Committee may reduce the sanction envisaged for the actual infringement accordingly. It will determine the extent of the mitigation as it sees fit; it shall not go below the general lower limit of the fine applicable to the concerned infringement.

The fact that a natural Person is not anymore a member of the UIM or has left a member of the UIM neither cancel out liability nor prevents from carrying out disciplinary proceedings. The same provision applies to legal Persons members of the UIM.

## THE ETHICAL PILLARS OF THE UIM

### 1.1 Equality

Discrimination and harassment against others on grounds of race, disability, marital status, sex, sexuality, age, political or religious conviction are not condoned in Powerboating.

All forms of harassment, be they physical, mental, professional or sexual, are strictly prohibited. Powerboating promotes the inclusion of men and women equally.

### 1.2 Fair Play

Fair play is the guiding principle in the sport of Powerboating. All Participants taking part in Powerboating shall behave with fairness and honesty.

All Participants shall operate within and abide by the rules of the sport.

All doping practices at all levels are strictly prohibited. The provisions against doping in the Anti-Doping Code shall be scrupulously observed. Powerboating is committed to be a drug free sport.

### 1.3 Respect

Powerboating shall be characterised by mutual respect and self-responsibility. All Participants involved in powerboating shall be treated with dignity.

The contribution that people make to the sport shall be recognised.

In pursuing the sport's goals, the governance of Powerboating shall be mindful of the physical and psychological well-being of its members.

Violence and abusive behaviour are not tolerated.

#### **1.4 Integrity**

All Persons subject to this Code shall Use due care and diligence in fulfilling their roles for, and on behalf of, the UIM or Powerboating in general.

Decisions by the UIM will be made in accordance with established procedures, objectively, fairly and with honesty and integrity.

Conflicts of interest must be avoided.

In discharging their duties to UIM, all Participants shall act for the benefit of UIM when making decisions that affect, or may affect, UIM and to do so without reference to their own personal interests, either financial or otherwise.

When performing an activity for UIM or before being elected or appointed, the candidate or Participant shall disclose to the Executive Committee any personal interests that could be linked with their prospective UIM activities. The Executive Committee may draw the attention of the candidate or Participant to potential conflicts of interest that it identifies.

Participants shall avoid any situation that could lead to conflicts of interest. Potential conflicts of interest arise:

- a) if Participants have, or appear to have, private or personal interests that detract from their ability to perform their duties with integrity in an independent and purposeful manner. Private or personal interests include gaining any possible advantage for the Persons bound by this Code themselves, their family, relatives, friends and acquaintances;
- b) if the opinion or decision of an Official, acting alone or within an organisation, is influenced by, or may be reasonably considered as liable to be influenced by relations that such Official has, has had or is on the point of having, with another Person or organisation that would be affected by the Person's opinion or decision;
- c) if an Official is also involved in the executive day to day running of Continental/National federations of powerboating sports.

In the following non-exhaustive list of examples, the circumstances in which a conflict of interests could arise are personal and/or material involvement (salary, shareholding, various benefits) with:

- a) suppliers of the party concerned;
- b) sponsors, broadcasters, various contracting parties;
- c) organisations liable to benefit from the assistance of the party concerned (including subsidy, approval clause or election).

Participants shall not perform their duties in matters with an existing or potential conflict of interest. Should a conflict of interest, or the appearance of a conflict of interest, arise, or if there is a danger of such conflict arising, the individual concerned must refrain from taking any further part in the handling of the matter. If it is unclear whether such a conflict of interest exists in any given situation, the matter may be submitted to the Ethics Panel.

If an objection is made concerning an existing or potential conflict of interest of a Participant, it shall be reported immediately to the Ethics Panel for appropriate measures.

If an Official neglects to declare a situation of a potential conflict of interest, any interested party in the UIM may refer the matter to the Executive Committee. When such a situation regards the President or any member of the Executive Committee, the member concerned shall abstain from taking part in the meetings of the Executive Committee where his/her position is to be adjudged, without prejudice of his/her right of defence.

No Participant shall, directly or indirectly, solicit, accept or offer any concealed remuneration, commission, gifts, benefit or service of any nature connected with their participation in powerboating activities or with their function as an Official.

No Participant shall, directly or indirectly bribe or Attempt to bribe third parties or urge or incite others to do so in order to gain an advantage for them or a third party.

No Participant shall solicit or accept benefits, entertainment or gifts in exchange for, or as a condition of, the exercise of their duties, or as an inducement for performing an act associated with their duties or responsibilities, except that gifts, hospitality or other r benefits associated with their official duties and responsibilities may be accepted if such gifts, hospitality or other benefits:

- a) are within the bounds of propriety, a normal expression of courtesy, or within the normal standards of hospitality;
- b) would not bring suspicion on the Official's objectivity and impartiality;
- c) would not compromise the integrity of UIM.

No Participant may be involved with any company, association, firm or Person whose activity is inconsistent with the objectives or interests of UIM. If it is unclear, whether this kind of a connection exists in any given situation, the matter shall be submitted to the Executive Committee for a decision.

Anyone subject to this Code shall not bet on Powerboating either directly or indirectly and shall not Use any privileged, sensitive or inside information they may have in order to profit or facilitate third Persons to profit from such information.

Anyone subject to this Code shall not perform corrupt practices relating to the sport of Powerboating, including improperly influencing either the course of an Event (partially or entirely) or the outcomes and results of an Event or race.

Anyone subject to this Code is forbidden from having stakes, either actively or passively, in any entity or, organization that promotes, brokers, arranges or conducts such activities or transactions.

Anyone subject to this Code shall exercise due care and diligence in fulfilling their roles for, or on behalf of UIM and not disclose information received if such disclosure is made maliciously in order to damage the interests of UIM or to obtain an unjust advantage or profit.

No UIM staff, governance bodies and other committee or commission member shall make adverse comments on a policy adopted by the UIM once the UIM decision has been taken.

### **1.5 Environment**

The UIM is committed to raise environmental performance of power boating and make our sport a vector of environmental protection and sustainable development.

UIM looks to youth to breed a future for sportsmanship and safety while nurturing a passion and respect for water and its environment.

The UIM will promote the optimal Use of resources and materials, efficient logistics and transport, reduction of polluting discharges to water and emissions to air.

## **2. GENERAL CONDUCT REGULATIONS**

### **2.1 Basic rules**

All Participants shall show commitment to an ethical attitude while fulfilling their task. They shall pledge to behave in accordance with the ethical pillars of the UIM.

Participants may not abuse their position as part of their function in any way, especially to take advantage of their function for private aims or gains.

### **2.2 Representational duties**

Participants shall represent UIM honestly, respectably and with integrity.

### **2.3 Conduct towards government and private organizations**

In dealings with government institutions, national and International organizations, associations and groupings, Participants shall, in addition to observing the basic rules of art.2.1, remain politically neutral, in accordance with the principles and objectives of UIM and act in a manner compatible with their function and integrity.

### **2.4 Ban on discrimination**

Participants may not act in a discriminatory manner, especially with regard to ethnicity, race, culture, politics, religion, gender or language.

### **2.5 Eligibility and dismissal**

Only those Persons who demonstrate a high degree of ethics and integrity and pledge to observe the provisions of this Code without reservation are eligible to serve as UIM officials. Anyone who do not comply with these conditions are either no longer eligible or shall be removed from office.

### **2.6 Protection of personal rights**

During the course of their activities, Participants shall ensure that the personal rights of those Persons whom they contact and with whom they deal are protected, respected and safeguarded.

### **2.7 Loyalty and confidentiality**

While performing their duties, participants shall remain loyal to UIM Depending on their function, any information divulged to officials during the course of their duties shall be treated as confidential. Any information or opinions shall be passed on in accordance with the principles and objectives of UIM.

### 3. PROCEEDINGS

The UIM Executive Committee shall have exclusive jurisdiction on any infringement of the rules contemplated in this Code. Anyone who has interest can refer to the UIM Executive Committee the infringement of this Code of Ethics. Proceedings before the UIM Executive Committee shall be without particular formalities, provided that the right of defence and the principles of fair process are always respected.

The UIM Executive Committee appoints an investigator, who may, but not necessarily has to a member of the Executive Committee. The Investigator shall investigate the case and deliver to the UIM Executive Committee a written report. Such report shall be sent to the party or the parties concerned, with an invitation to submit defensive briefs and appear before the Executive Committee at the discussion hearing.

At the discussion hearing parties may be assisted by an attorney. The Executive Committee members and the appointed Investigator may attend the hearing also by video or tele-conference.

The infringements of the rules of this Code shall be sanctioned as follows:

- i) First violation, up to six months suspension and up to Euro 5,000 fine;
- ii) Second violation, from six months up to two years suspension and from Euro 5,000 up to Euro 10,000 fine;
- iii) Third violation, life ban and Euro 15,000 fine;
- iv) Highly serious infringements shall be sanctioned with no less than a two years suspension and then Euro 15,000 fine.

Should the infringement be committed by a consultant or any other contracted party of the UIM, the relevant contract shall be immediately terminated.

Should the infringement be committed to obtain an illicit benefit, including sport outcomes, the relevant results, such as titles, prizes etc. shall not be awarded or revoked if already awarded.

The Executive Committee may reduce the sanctions envisaged for each actual infringement in accordance with the extent of the mitigation as it sees fit. In any Event the sanction shall not go below the general lower limit of the fine applicable to the concerned infringement.

The parties to the proceedings shall keep strictly confidential and shall not disclose any information received or appraised during the proceedings. The decision taken by the UIM Executive Committee shall be published on the UIM website. The sanctioned party shall have 21 days as of the publication of the decision on the UIM website to appeal the decision before the Court of Arbitration for Sport in Lausanne.

### 4. ENFORCEMENT

This Code of Ethics is an integral and binding part of the UIM By-Laws and has entered into force and is fully effective since approval by the General Assembly on 26<sup>th</sup> October 2014.



# **ANTI-DOPING RULES 2026**

## TABLE OF CONTENTS

<b>ANTI-DOPING RULES 2023</b> .....	<b>121</b>
INTRODUCTION .....	123
ARTICLE 1 DEFINITION OF DOPING.....	125
ARTICLE 2 ANTI-DOPING RULE VIOLATIONS .....	125
ARTICLE 3 PROOF OF DOPING .....	129
ARTICLE 4 THE PROHIBITED LIST .....	131
ARTICLE 5 TESTING AND INVESTIGATIONS.....	135
ARTICLE 6 ANALYSIS OF SAMPLES .....	139
ARTICLE 7 RESULTS MANAGEMENT: RESPONSIBILITY, INITIAL REVIEW, NOTICE AND PROVISIONAL SUSPENSIONS .....	141
ARTICLE 8 RESULTS MANAGEMENT: RIGHT TO A FAIR HEARING AND NOTICE OF HEARING DECISION.....	144
ARTICLE 9 AUTOMATIC DISQUALIFICATION OF INDIVIDUAL RESULTS .....	147
ARTICLE 10 SANCTIONS ON INDIVIDUALS .....	147
ARTICLE 11 CONSEQUENCES TO TEAMS .....	159
ARTICLE 12 SANCTIONS BY the UIM AGAINST OTHER SPORTING BODIES .....	159
ARTICLE 13 RESULTS MANAGEMENT: APPEALS .....	160
ARTICLE 14 CONFIDENTIALITY AND REPORTING .....	164
ARTICLE 15 IMPLEMENTATION OF DECISIONS .....	167
ARTICLE 16 STATUTE OF LIMITATIONS .....	169
ARTICLE 17 EDUCATION .....	169
ARTICLE 18 ADDITIONAL ROLES AND RESPONSIBILITIES OF NATIONAL AUTHORITIES ..	169
ARTICLE 19 ADDITIONAL ROLES AND RESPONSIBILITIES OF the UIM.....	170
ARTICLE 20 ADDITIONAL ROLES AND RESPONSIBILITIES OF ATHLETES.....	171
ARTICLE 21 ADDITIONAL ROLES AND RESPONSIBILITIES OF ATHLETE SUPPORT PERSONNEL .....	171
ARTICLE 22 ... ADDITIONAL ROLES AND RESPONSIBILITIES OF OTHER PERSONS SUBJECT TO THESE ANTI-DOPING RULES .....	172
ARTICLE 23 INTERPRETATION OF THE CODE .....	172
ARTICLE 24 FINAL PROVISIONS.....	173
APPENDIX 1 DEFINITIONS .....	175

## INTRODUCTION

### Preface

These Anti-Doping Rules are adopted and implemented in accordance with the UIM's responsibilities under the *Code*, and in furtherance of the UIM's continuing efforts to eradicate doping in sport.

These Anti-Doping Rules are sport rules governing the conditions under which sport is played. Aimed at enforcing anti-doping rules in a global and harmonized manner, they are distinct in nature from criminal and civil laws. They are not intended to be subject to or limited by any national requirements and legal standards applicable to criminal or civil proceedings, although they are intended to be applied in a manner which respects the principles of proportionality and human rights. When reviewing the facts and the law of a given case, all courts, arbitral tribunals and other adjudicating bodies should be aware of and respect the distinct nature of these Anti-Doping Rules, which implement the *Code*, and the fact that these rules represent the consensus of a broad spectrum of stakeholders around the world as to what is necessary to protect and ensure fair sport.

As provided in the *Code*, the UIM shall be responsible for conducting all aspects of *Doping Control*. Any aspect of *Doping Control* or anti-doping *Education* may be delegated by the UIM to a *Delegated Third Party*, such as the International Testing Agency (ITA), however, the UIM shall require the *Delegated Third Party* to perform such aspects in compliance with the *Code*, *International Standards*, and these Anti-Doping Rules. the UIM may delegate its adjudication responsibilities and *Results Management* to the CAS Anti-Doping Division.

When the UIM has delegated its responsibilities to implement part or all of *Doping Control* to the ITA or to any other *Delegated Third Party*, any reference to the UIM in these *Rules* should be intended as a reference to the ITA or to the other *Delegated Third Party*, where applicable and within the context of the aforementioned delegation. the UIM shall always remain fully responsible for ensuring that any delegated aspects are performed in compliance with the *Code*.

Italicized terms in these Anti-Doping Rules are defined terms in Appendix 1.

Unless otherwise specified, references to Articles are references to Articles of these Anti-Doping Rules.

### Fundamental Rationale for the *Code* and the UIM's Anti-Doping Rules

Anti-doping programs are founded on the intrinsic value of sport. This intrinsic value is often referred to as "the spirit of sport": the ethical pursuit of human excellence through the dedicated perfection of each *Athlete's* natural talents.

Anti-doping programs seek to protect the health of *Athletes* and to provide the opportunity for *Athletes* to pursue human excellence without the *Use of Prohibited Substances and Methods*.

Anti-doping programs seek to maintain the integrity of sport in terms of respect for rules, other competitors, fair competition, a level playing field, and the value of clean sport to the world.

The spirit of sport is the celebration of the human spirit, body and mind. It is the essence of Olympism and is reflected in the values we find in and through sport, including:

- Health
- Ethics, fair play and honesty
- *Athletes'* rights as set forth in the *Code*
- Excellence in performance
- Character and *Education*
- Fun and joy
- Teamwork
- Dedication and commitment
- Respect for rules and laws
- Respect for self and other *Participants*
- Courage

- Community and solidarity

The spirit of sport is expressed in how we play true.

Doping is fundamentally contrary to the spirit of sport.

### Scope of these Anti-Doping Rules

These Anti-Doping Rules shall apply to:

- (a) the UIM, including its board members, directors, officers and specified employees, and *Delegated Third Parties* and their employees, who are involved in any aspect of *Doping Control*;
- (b) each of its *National Authorities*, including their board members, directors, officers and specified employees, and *Delegated Third Parties* and their employees, who are involved in any aspect of *Doping Control*;
- (c) the following *Athletes*, *Athlete Support Personnel* and other *Persons*:
  - (i) all *Athletes* and *Athlete Support Personnel* who are members of the UIM, or of any *National Authority*, or of any member or affiliate organization of any *National Authority* (including any clubs, teams, associations, or leagues);
  - (ii) all *Athletes* and *Athlete Support Personnel* who participate in such capacity in *Events*, *Competitions* and other activities organized, convened, authorized or recognized by the UIM, or any *National Authority*, or by any member or affiliate organization of any *National Authority* (including any clubs, teams, associations, or leagues), wherever held;
  - (iii) any other *Athlete* or *Athlete Support Personnel* or other *Person* who, by virtue of an accreditation, a license or other contractual arrangement, or otherwise, is subject to the authority of the UIM, or of any *National Authority*, or of any member or affiliate organization of any *National Authority* (including any clubs, teams, associations, or leagues), for purposes of anti-doping; and;
  - (iv) *Athletes* who are not regular members of the UIM or of one of its *National Authorities* but who want to be eligible to compete in a particular *International Event*.

Each of the abovementioned *Persons* is deemed, as a condition of his or her participation or involvement in the sport, to have agreed to and be bound by these Anti-Doping Rules, and to have submitted to the authority of the UIM to enforce these Anti-Doping Rules, including any *Consequences* for the breach thereof, and to the jurisdiction of the hearing panels specified in Article 8 and Article 13 to hear and determine cases and appeals brought under these Anti-Doping Rules.<sup>1</sup>

Within the overall pool of *Athletes* set out above who are bound by and required to comply with these Anti-Doping Rules, the following *Athletes* shall be considered to be *International-Level Athletes* for the purposes of these Anti-Doping Rules, and, therefore, the specific provisions in these Anti-Doping Rules applicable to *International-Level Athletes* (e.g., *Testing*, *TUEs*, whereabouts, and *Results Management*) shall apply to such *Athletes*:

- (a) *Athletes* who hold the following license: UIM Superlicence, UIM Serieslicence;
- (b) *Athletes* who compete in any of the following *International Events*: UIM World Championship or Cup, UIM Continental Championships,

<sup>1</sup> [Comment: Where the Code requires a Person other than an Athlete or Athlete Support Person to be bound by the Code, such Person would of course not be subject to Sample collection or Testing, and would not be charged with an anti-doping rule violation under the Code for Use or Possession of a Prohibited Substance or Prohibited Method. Rather, such Person would only be subject to discipline for a violation of Code Articles 2.5 (Tampering), 2.7 (Trafficking), 2.8 (Administration), 2.9 (Complicity), 2.10 (Prohibited Association) and 2.11 (Retaliation). Furthermore, such Person would be subject to the additional roles and responsibilities according to Code Article 21.3. Also, the obligation to require an employee to be bound by the Code is subject to applicable law.]

The UIM shall ensure that, as in Article 19 of these Anti-Doping Rules, any arrangements with their board members, directors, officers, and specified employees, as well as with the *Delegated Third Parties* and their employees – either employment, contractual or otherwise – have explicit provisions incorporated according to which such *Persons* are bound by, agree to comply with these Anti-Doping Rules, and agree on the UIM's authority to solve the anti-doping cases.]

- (c) *Athletes* included in the UIM Registered Testing Pool, Testing Pool and any other Pool established by UIM;

## ARTICLE 1 DEFINITION OF DOPING

Doping is defined as the occurrence of one or more of the anti-doping rule violations set forth in Article 2.1 through Article 2.11 of these Anti-Doping Rules.

## ARTICLE 2 ANTI-DOPING RULE VIOLATIONS

The purpose of Article 2 is to specify the circumstances and conduct which constitute anti-doping rule violations. Hearings in doping cases will proceed based on the assertion that one or more of these specific rules have been violated.

*Athletes* or other *Persons* shall be responsible for knowing what constitutes an anti-doping rule violation and the substances and methods which have been included on the *Prohibited List*.

The following constitute anti-doping rule violations:

### 2.1 Presence of a Prohibited Substance or its Metabolites or Markers in an Athlete's Sample

- 2.1.1** It is the *Athletes'* personal duty to ensure that no *Prohibited Substance* enters their bodies. *Athletes* are responsible for any *Prohibited Substance* or its *Metabolites* or *Markers* found to be present in their *Samples*. Accordingly, it is not necessary that intent, *Fault*, *Negligence* or knowing *Use* on the *Athlete's* part be demonstrated in order to establish an anti-doping rule violation under Article 2.1.<sup>2</sup>
- 2.1.2** Sufficient proof of an anti-doping rule violation under Article 2.1 is established by any of the following: presence of a *Prohibited Substance* or its *Metabolites* or *Markers* in the *Athlete's A Sample* where the *Athlete* waives analysis of the *B Sample* and the *B Sample* is not analysed; or, where the *Athlete's B Sample* is analysed and the analysis of the *Athlete's B Sample* confirms the presence of the *Prohibited Substance* or its *Metabolites* or *Markers* found in the *Athlete's A Sample*; or where the *Athlete's A* or *B Sample* is split into two (2) parts and the analysis of the confirmation part of the split *Sample* confirms the presence of the *Prohibited Substance* or its *Metabolites* or *Markers* found in the first part of the split *Sample* or the *Athlete* waives analysis of the confirmation part of the split *Sample*.<sup>3</sup>
- 2.1.3** Excepting those substances for which a *Decision Limit* is specifically identified in the *Prohibited List* or a *Technical Document*, the presence of any reported quantity of a *Prohibited Substance* or its *Metabolites* or *Markers* in an *Athlete's Sample* shall constitute an anti-doping rule violation.
- 2.1.4** As an exception to the general rule of Article 2.1, the *Prohibited List*, *International Standards* or *Technical Documents* may establish special criteria for reporting or the evaluation of certain *Prohibited Substances*.

<sup>2</sup> [Comment to Article 2.1.1: An anti-doping rule violation is committed under this Article without regard to an Athlete's Fault. This rule has been referred to in various CAS decisions as "Strict Liability". An Athlete's Fault is taken into consideration in determining the Consequences of this anti-doping rule violation under Article 10. This principle has consistently been upheld by CAS.]

<sup>3</sup> [Comment to Article 2.1.2: The Anti-Doping Organization with Results Management responsibility may, at its discretion, choose to have the B Sample analysed even if the Athlete does not request the analysis of the B Sample.]

## 2.2 Use or Attempted Use by an Athlete of a Prohibited Substance or a Prohibited Method

4

**2.2.1** It is the *Athletes'* personal duty to ensure that no *Prohibited Substance* enters their bodies and that no *Prohibited Method* is *Used*. Accordingly, it is not necessary that intent, *Fault*, *Negligence* or knowing *Use* on the *Athlete's* part be demonstrated in order to establish an anti-doping rule violation for *Use* of a *Prohibited Substance* or a *Prohibited Method*.

**2.2.2** The success or failure of the *Use* or *Attempted Use* of a *Prohibited Substance* or *Prohibited Method* is not material. It is sufficient that the *Prohibited Substance* or *Prohibited Method* was *Used* or *Attempted* to be *Used* for an anti-doping rule violation to be committed.<sup>5</sup>

## 2.3 Evading, Refusing or Failing to Submit to *Sample* Collection by an *Athlete*

Evading *Sample* collection; or refusing or failing to submit to *Sample* collection without compelling justification after notification by a duly authorized *Person*.<sup>6</sup>

## 2.4 Whereabouts Failures by an *Athlete*

Any combination of three (3) missed tests and/or filing failures, as defined in the *International Standard for Results Management*, within a twelve (12) month period by an *Athlete* in a *Registered Testing Pool*.

## 2.5 Tampering or Attempted Tampering with any Part of Doping Control by an *Athlete* or *Other Person*

## 2.6 Possession of a Prohibited Substance or a Prohibited Method by an *Athlete* or *Athlete Support Person*

**2.6.1** *Possession* by an *Athlete In-Competition* of any *Prohibited Substance* or any *Prohibited Method*, or *Possession* by an *Athlete Out-of-Competition* of any *Prohibited Substance* or any *Prohibited Method* which is prohibited *Out-of-Competition* unless the *Athlete* establishes that the *Possession* is consistent

<sup>4</sup> [Comment to Article 2.2: It has always been the case that *Use* or *Attempted Use* of a *Prohibited Substance* or *Prohibited Method* may be established by any reliable means. As noted in the Comment to Article 3.2, unlike the proof required to establish an anti-doping rule violation under Article 2.1, *Use* or *Attempted Use* may also be established by other reliable means such as admissions by the *Athlete*, witness statements, documentary evidence, conclusions drawn from longitudinal profiling, including data collected as part of the *Athlete Biological Passport*, or other analytical information which does not otherwise satisfy all the requirements to establish "Presence" of a *Prohibited Substance* under Article 2.1.

For example, *Use* may be established based upon reliable analytical data from the analysis of an A *Sample* (without confirmation from an analysis of a B *Sample*) or from the analysis of a B *Sample* alone where the Anti-Doping Organization provides a satisfactory explanation for the lack of confirmation in the other *Sample*.]

<sup>5</sup> [Comment to Article 2.2.2: Demonstrating the "Attempted Use" of a *Prohibited Substance* or a *Prohibited Method* requires proof of intent on the *Athlete's* part. The fact that intent may be required to prove this particular anti-doping rule violation does not undermine the Strict Liability principle established for violations of Article 2.1 and violations of Article 2.2 in respect of *Use* of a *Prohibited Substance* or *Prohibited Method*.

An *Athlete's Use* of a *Prohibited Substance* constitutes an anti-doping rule violation unless such substance is not prohibited *Out-of-Competition* and the *Athlete's Use* takes place *Out-of-Competition*. (However, the presence of a *Prohibited Substance* or its *Metabolites* or *Markers* in a *Sample* collected *In-Competition* is a violation of Article 2.1 regardless of when that substance might have been administered.)]

<sup>6</sup> [Comment to Article 2.3: For example, it would be an anti-doping rule violation of "evading *Sample* collection" if it were established that an *Athlete* was deliberately avoiding a *Doping Control* official to evade notification or *Testing*. A violation of "failing to submit to *Sample* collection" may be based on either intentional or negligent conduct of the *Athlete*, while "evading" or "refusing" *Sample* collection contemplates intentional conduct by the *Athlete*.]

with a *Therapeutic Use Exemption* (“TUE”) granted in accordance with Article 4.4 or other acceptable justification.

- 2.6.2** *Possession by an Athlete Support Person In-Competition of any Prohibited Substance or any Prohibited Method, or Possession by an Athlete Support Person Out-of-Competition of any Prohibited Substance or any Prohibited Method* which is prohibited *Out-of-Competition* in connection with an *Athlete, Competition* or training, unless the *Athlete Support Person* establishes that the *Possession* is consistent with a *TUE* granted to an *Athlete* in accordance with Article 4.4 or other acceptable justification.<sup>7</sup>

**2.7 Trafficking or Attempted Trafficking in any Prohibited Substance or Prohibited Method by an Athlete or Other Person**

**2.8 Administration or Attempted Administration by an Athlete or Other Person to any Athlete In-Competition of any Prohibited Substance or Prohibited Method, or Administration or Attempted Administration to any Athlete Out-of-Competition of any Prohibited Substance or any Prohibited Method that is Prohibited Out-of-Competition**

**2.9 Complicity or Attempted Complicity by an Athlete or Other Person**

Assisting, encouraging, aiding, abetting, conspiring, covering up or any other type of intentional complicity or *Attempted* complicity involving an anti-doping rule violation, *Attempted* anti-doping rule violation or violation of Article 10.14.1 by another *Person*.<sup>8</sup>

**2.10 Prohibited Association by an Athlete or Other Person**

- 2.10.1** Association by an *Athlete* or other *Person* subject to the authority of an *Anti-Doping Organization* in a professional or sport-related capacity with any *Athlete Support Person* who:

**2.10.1.1** If subject to the authority of an *Anti-Doping Organization*, is serving a period of *Ineligibility*; or

**2.10.1.2** If not subject to the authority of an *Anti-Doping Organization* and where *Ineligibility* has not been addressed in a *Results Management* process pursuant to the *Code*, has been convicted or found in a criminal, disciplinary or professional proceeding to have engaged in conduct which would have constituted a violation of anti-doping rules if *Code-compliant* rules had been applicable to such *Person*. The disqualifying status of such *Person* shall be in force for the longer of six (6) years from the criminal, professional or disciplinary decision or the duration of the criminal, disciplinary or professional sanction imposed; or

**2.10.1.3** Is serving as a front or intermediary for an individual described in Article 2.10.1.1 or 2.10.1.2.

<sup>7</sup> [Comment to Articles 2.6.1 and 2.6.2: Acceptable justification would not include, for example, buying or Possessing a Prohibited Substance for purposes of giving it to a friend or relative, except under justifiable medical circumstances where that Person had a physician’s prescription, e.g., buying Insulin for a diabetic child.]

[Comment to Article 2.6.1 and 2.6.2: Acceptable justification may include, for example, (a) an Athlete or a team doctor carrying Prohibited Substances or Prohibited Methods for dealing with acute and emergency situations (e.g., an epinephrine auto-injector), or (b) an Athlete Possessing a Prohibited Substance or Prohibited Method for therapeutic reasons shortly prior to applying for and receiving a determination on a TUE.]

<sup>8</sup> [Comment to Article 2.9: Complicity or Attempted Complicity may include either physical or psychological assistance.]

- 2.10.2** To establish a violation of Article 2.10, an *Anti-Doping Organization* must establish that the *Athlete* or other *Person* knew of the *Athlete Support Person's* disqualifying status.

The burden shall be on the *Athlete* or other *Person* to establish that any association with an *Athlete Support Person* described in Article 2.10.1.1 or 2.10.1.2 is not in a professional or sport-related capacity and/or that such association could not have been reasonably avoided.

*Anti-Doping Organizations* that are aware of *Athlete Support Personnel* who meet the criteria described in Article 2.10.1.1, 2.10.1.2, or 2.10.1.3 shall submit that information to WADA.<sup>9</sup>

## **2.11 Acts by an Athlete or Other Person to Discourage or Retaliate Against Reporting to Authorities**

Where such conduct does not otherwise constitute a violation of Article 2.5:

- 2.11.1** Any act which threatens or seeks to intimidate another *Person* with the intent of discouraging the *Person* from the good-faith reporting of information that relates to an alleged anti-doping rule violation or alleged non-compliance with the *Code to WADA*, an *Anti-Doping Organization*, law enforcement, regulatory or professional disciplinary body, hearing body or *Person* conducting an investigation for WADA or an *Anti-Doping Organization*.

- 2.11.2** Retaliation against a *Person* who, in good faith, has provided evidence or information that relates to an alleged anti-doping rule violation or alleged non-compliance with the *Code to WADA*, an *Anti-Doping Organization*, law enforcement, regulatory or professional disciplinary body, hearing body or *Person* conducting an investigation for WADA or an *Anti-Doping Organization*.

For purposes of Article 2.11, retaliation, threatening and intimidation include an act taken against such *Person* either because the act lacks a good faith basis or is a disproportionate response.<sup>10</sup>

<sup>9</sup> [Comment to Article 2.10: Athletes and other Persons must not work with coaches, trainers, physicians or other Athlete Support Personnel who are Ineligible on account of an anti-doping rule violation or who have been criminally convicted or professionally disciplined in relation to doping. This also prohibits association with any other Athlete who is acting as a coach or Athlete Support Person while serving a period of Ineligibility. Some examples of the types of association which are prohibited include: obtaining training, strategy, technique, nutrition or medical advice; obtaining therapy, treatment or prescriptions; providing any bodily products for analysis; or allowing the Athlete Support Person to serve as an agent or representative. Prohibited association need not involve any form of compensation.]

While Article 2.10 does not require the Anti-Doping Organization to notify the Athlete or other Person about the Athlete Support Person's disqualifying status, such notice, if provided, would be important evidence to establish that the Athlete or other Person knew about the disqualifying status of the Athlete Support Person.]

<sup>10</sup> [Comment to Article 2.11.2: This Article is intended to protect Persons who make good faith reports, and does not protect Persons who knowingly make false reports.]

[Comment to Article 2.11.2: Retaliation would include, for example, actions that threaten the physical or mental well-being or economic interests of the reporting Persons, their families or associates. Retaliation would not include an Anti-Doping Organization asserting in good faith an anti-doping rule violation against the reporting Person. For purposes of Article 2.11, a report is not made in good faith where the Person making the report knows the report to be false.]

## ARTICLE 3 PROOF OF DOPING

### 3.1 Burdens and Standards of Proof

The UIM shall have the burden of establishing that an anti-doping rule violation has occurred. The standard of proof shall be whether the UIM has established an anti-doping rule violation to the comfortable satisfaction of the hearing panel bearing in mind the seriousness of the allegation which is made. This standard of proof in all cases is greater than a mere balance of probability but less than proof beyond a reasonable doubt. Where these Anti-Doping Rules place the burden of proof upon the *Athlete* or other *Person* alleged to have committed an anti-doping rule violation to rebut a presumption or establish specified facts or circumstances, except as provided in Articles 3.2.2 and 3.2.3, the standard of proof shall be by a balance of probability.<sup>11</sup>

### 3.2 Methods of Establishing Facts and Presumptions

Facts related to anti-doping rule violations may be established by any reliable means, including admissions.<sup>12</sup> The following rules of proof shall be applicable in doping cases:

**3.2.1** Analytical methods or *Decision Limits* approved by WADA after consultation within the relevant scientific community or which have been the subject of peer review are presumed to be scientifically valid. Any *Athlete* or other *Person* seeking to challenge whether the conditions for such presumption have been met or to rebut this presumption of scientific validity shall, as a condition precedent to any such challenge, first notify WADA of the challenge and the basis of the challenge. The initial hearing body, appellate body or CAS, on its own initiative, may also inform WADA of any such challenge. Within ten (10) days of WADA's receipt of such notice and the case file related to such challenge, WADA shall also have the right to intervene as a party, appear as *amicus curiae* or otherwise provide evidence in such proceeding. In cases before CAS, at WADA's request, the CAS panel shall appoint an appropriate scientific expert to assist the panel in its evaluation of the challenge.<sup>13</sup>

**3.2.2** WADA-accredited laboratories, and other laboratories approved by WADA, are presumed to have conducted *Sample* analysis and custodial procedures in accordance with the *International Standard* for Laboratories. The *Athlete* or other *Person* may rebut this presumption by establishing that a departure from the *International Standard* for Laboratories occurred which could reasonably have caused the *Adverse Analytical Finding*.

If the *Athlete* or other *Person* rebuts the preceding presumption by showing that a departure from the *International Standard* for Laboratories occurred which could reasonably have caused the *Adverse Analytical Finding*, then

<sup>11</sup> Comment to Article 3.1: This standard of proof required to be met by the UIM is comparable to the standard which is applied in most countries to cases involving professional misconduct.]

<sup>12</sup> [Comment to Article 3.2: For example, the UIM may establish an anti-doping rule violation under Article 2.2 based on the *Athlete's* admissions, the credible testimony of third *Persons*, reliable documentary evidence, reliable analytical data from either an A or B *Sample* as provided in the Comments to Article 2.2, or conclusions drawn from the profile of a series of the *Athlete's* blood or urine *Samples*, such as data from the *Athlete Biological Passport*.]

[<sup>13</sup> Comment to Article 3.2.1: For certain *Prohibited Substances*, WADA may instruct WADA-accredited laboratories not to report *Samples* as an *Adverse Analytical Finding* if the estimated concentration of the *Prohibited Substance* or its *Metabolites* or *Markers* is below a *Minimum Reporting Level*. WADA's decision in determining that *Minimum Reporting Level* or in determining which *Prohibited Substances* should be subject to *Minimum Reporting Levels* shall not be subject to challenge. Further, the laboratory's estimated concentration of such *Prohibited Substance* in a *Sample* may only be an estimate. In no event shall the possibility that the exact concentration of the *Prohibited Substance* in the *Sample* may be below the *Minimum Reporting Level* constitute a defense to an anti-doping rule violation based on the presence of that *Prohibited Substance* in the *Sample*.]

the UIM shall have the burden to establish that such departure did not cause the *Adverse Analytical Finding*.<sup>14</sup>

**3.2.3** Departures from any other *International Standard* or other anti-doping rule or policy set forth in the *Code* or these Anti-Doping Rules shall not invalidate analytical results or other evidence of an anti-doping rule violation, and shall not constitute a defense to an anti-doping rule violation;<sup>15</sup> provided, however, if the *Athlete* or other *Person* establishes that a departure from one of the specific *International Standard* provisions listed below could reasonably have caused an anti-doping rule violation based on an *Adverse Analytical Finding* or whereabouts failure, then the UIM shall have the burden to establish that such departure did not cause the *Adverse Analytical Finding* or the whereabouts failure:

- (i) a departure from the *International Standard* for *Testing* and *Investigations* related to *Sample* collection or *Sample* handling which could reasonably have caused an anti-doping rule violation based on an *Adverse Analytical Finding*, in which case the UIM shall have the burden to establish that such departure did not cause the *Adverse Analytical Finding*;
- (ii) a departure from the *International Standard* for *Results Management* or *International Standard* for *Testing* and *Investigations* related to an *Adverse Passport Finding* which could reasonably have caused an anti-doping rule violation, in which case the UIM shall have the burden to establish that such departure did not cause the anti-doping rule violation;
- (iii) a departure from the *International Standard* for *Results Management* related to the requirement to provide notice to the *Athlete* of the *B Sample* opening which could reasonably have caused an anti-doping rule violation based on an *Adverse Analytical Finding*, in which case the UIM shall have the burden to establish that such departure did not cause the *Adverse Analytical Finding*;<sup>16</sup>
- (iv) a departure from the *International Standard* for *Results Management* related to *Athlete* notification which could reasonably have caused an anti-doping rule violation based on a whereabouts failure, in which case the UIM shall have the burden to establish that such departure did not cause the whereabouts failure.

<sup>14</sup> [Comment to Article 3.2.2: The burden is on the *Athlete* or other *Person* to establish, by a balance of probability, a departure from the *International Standard* for *Laboratories* that could reasonably have caused the *Adverse Analytical Finding*. Thus, once the *Athlete* or other *Person* establishes the departure by a balance of probability, the *Athlete* or other *Person*'s burden on causation is the somewhat lower standard of proof – "could reasonably have caused." If the *Athlete* or other *Person* satisfies these standards, the burden shifts to the UIM to prove to the comfortable satisfaction of the hearing panel that the departure did not cause the *Adverse Analytical Finding*.]

<sup>15</sup> [Comment to Article 3.2.3: Departures from an *International Standard* or other rule unrelated to *Sample* collection or handling, *Adverse Passport Finding*, or *Athlete* notification relating to whereabouts failure or *B Sample* opening – e.g., the *International Standards for Education*, *International Standard for the Protection of Privacy and Personal Information* or *International Standard for Therapeutic Use Exemptions* – may result in compliance proceedings by WADA but are not a defense in an anti-doping rule violation proceeding and are not relevant on the issue of whether the *Athlete* committed an anti-doping rule violation. Similarly, the UIM's violation of the document referenced in Article 20.7.7 of the *Code* shall not constitute a defense to an anti-doping rule violation.]

<sup>16</sup> [Comment to Article 3.2.3 (iii): the UIM would meet its burden to establish that such departure did not cause the *Adverse Analytical Finding* by showing that, for example, the *B Sample* opening and analysis were observed by an independent witness and no irregularities were observed.]

- 3.2.4** The facts established by a decision of a court or professional disciplinary tribunal of competent jurisdiction which is not the subject of a pending appeal shall be irrebuttable evidence against the *Athlete* or other *Person* to whom the decision pertained of those facts unless the *Athlete* or other *Person* establishes that the decision violated principles of natural justice.
- 3.2.5** The hearing panel in a hearing on an anti-doping rule violation may draw an inference adverse to the *Athlete* or other *Person* who is asserted to have committed an anti-doping rule violation based on the *Athlete's* or other *Person's* refusal, after a request made in a reasonable time in advance of the hearing, to appear at the hearing (either in person or telephonically as directed by the hearing panel) and to answer questions from the hearing panel or the UIM.

## ARTICLE 4 THE *PROHIBITED LIST*

### 4.1 Incorporation of the *Prohibited List*

These Anti-Doping Rules incorporate the *Prohibited List*, which is published and revised by WADA as described in Article 4.1 of the *Code*.

Unless provided otherwise in the *Prohibited List* or a revision, the *Prohibited List* and revisions shall go into effect under these Anti-Doping Rules three (3) months after publication by WADA, without requiring any further action by the UIM or its *National Authorities*. All *Athletes* and other *Persons* shall be bound by the *Prohibited List*, and any revisions thereto, from the date they go into effect, without further formality. It is the responsibility of all *Athletes* and other *Persons* to familiarize themselves with the most up-to-date version of the *Prohibited List* and all revisions thereto.

The UIM shall provide its *National Authorities* with the most recent version of the *Prohibited List*. Each *National Authority* shall in turn ensure that its members, and the constituents of its members, are also provided with the most recent version of the *Prohibited List*.<sup>17</sup>

### 4.2 Prohibited Substances and Prohibited Methods Identified on the Prohibited List

#### 4.2.1 *Prohibited Substances and Prohibited Methods*

The *Prohibited List* shall identify those *Prohibited Substances* and *Prohibited Methods* which are prohibited as doping at all times (both *In-Competition* and *Out-of-Competition*) because of their potential to enhance performance in future *Competitions* or their masking potential, and those substances and methods which are prohibited *In-Competition* only. The *Prohibited List* may be expanded by WADA for a particular sport. *Prohibited Substances* and *Prohibited Methods* may be included in the *Prohibited List* by general category (e.g., anabolic agents) or by specific reference to a particular substance or method.<sup>18</sup>

#### 4.2.2 *Specified Substances or Specified Methods*

For purposes of the application of Article 10, all *Prohibited Substances* shall be *Specified Substances* except as identified on the *Prohibited List*. No *Prohibited Method* shall be a

<sup>17</sup> [Comment to Article 4.1: The current *Prohibited List* is available on WADA's website at <https://www.wada-ama.org>. The *Prohibited List* will be revised and published on an expedited basis whenever the need arises. However, for the sake of predictability, a new *Prohibited List* will be published every year whether or not changes have been made.]

<sup>18</sup> [Comment to Article 4.2.1: *Out-of-Competition* Use of a substance which is only prohibited *In-Competition* is not an anti-doping rule violation unless an Adverse Analytical Finding for the substance or its Metabolites or Markers is reported for a Sample collected *In-Competition*.]

*Specified Method* unless it is specifically identified as a *Specified Method* on the *Prohibited List*.<sup>19</sup>

#### 4.2.3 Substances of Abuse

For purposes of applying Article 10, *Substances of Abuse* shall include those *Prohibited Substances* which are specifically identified as *Substances of Abuse* on the *Prohibited List* because they are frequently abused in society outside of the context of sport.

### 4.3 WADA's Determination of the *Prohibited List*

WADA's determination of the *Prohibited Substances* and *Prohibited Methods* that will be included on the *Prohibited List*, the classification of substances into categories on the *Prohibited List*, the classification of a substance as prohibited at all times or *In-Competition* only, the classification of a substance or method as a *Specified Substance*, *Specified Method* or *Substance of Abuse* is final and shall not be subject to any challenge by an *Athlete* or other *Person* including, but not limited to, any challenge based on an argument that the substance or method was not a masking agent or did not have the potential to enhance performance, represent a health risk or violate the spirit of sport.

### 4.4 Therapeutic Use Exemptions ("TUEs")

**4.4.1** The presence of a *Prohibited Substance* or its *Metabolites* or *Markers*, and/or the *Use* or *Attempted Use*, *Possession* or *Administration* or *Attempted Administration* of a *Prohibited Substance* or *Prohibited Method*, shall not be considered an anti-doping rule violation if it is consistent with the provisions of a *TUE* granted in accordance with the *International Standard for Therapeutic Use Exemptions*.

#### 4.4.2 TUE Applications

**4.4.2.1** *Athletes* who are not *International-Level Athletes* shall apply to their *National Anti-Doping Organization* for a *TUE*. If the *National Anti-Doping Organization* denies the application, the *Athlete* may appeal exclusively to the national-level appeal body described in Article 13.2.2.

**4.4.2.2** *Athletes* who are *International-Level Athletes* shall apply to the UIM.

#### 4.4.3 TUE Recognition<sup>20</sup>

**4.4.3.1** Where the *Athlete* already has a *TUE* granted by their *National Anti-Doping Organization* pursuant to Article 4.4 of the *Code* for the substance or method in question and provided that such *TUE* has been reported in accordance with Article 5.5 of the *International Standard for Therapeutic Use Exemptions*, the UIM will automatically recognize it for purposes of international-level

<sup>19</sup> [Comment to Article 4.2.2: The *Specified Substances* and *Methods* identified in Article 4.2.2 should not in any way be considered less important or less dangerous than other doping substances or methods. Rather, they are simply substances and methods which are more likely to have been consumed or used by an *Athlete* for a purpose other than the enhancement of sport performance.]

<sup>20</sup> [Comment to Article 4.4.3: If the UIM refuses to recognize a *TUE* granted by a *National Anti-Doping Organization* only because medical records or other information are missing that are needed to demonstrate satisfaction with the criteria in the *International Standard for Therapeutic Use Exemptions*, the matter should not be referred to WADA. Instead, the file should be completed and re-submitted to the UIM.]

[Comment to Article 4.4.3: the UIM may agree with a *National Anti-Doping Organization* that the *National Anti-Doping Organization* will consider *TUE* applications on behalf of the UIM.]

*Competition* without the need to review the relevant clinical information.

**4.4.3.2** If the UIM chooses to test an *Athlete* who is not an *International-Level Athlete*, the UIM must recognize a *TUE* granted to that *Athlete* by their *National Anti-Doping Organization* unless the *Athlete* is required to apply for recognition of the *TUE* pursuant to Articles 5.8 and 7.0 of the *International Standard for Therapeutic Use Exemptions*.

#### **4.4.4** *TUE* Application Process <sup>21</sup>

**4.4.4.1** If the *Athlete* does not already have a *TUE* granted by their *National Anti-Doping Organization* for the substance or method in question, the *Athlete* must apply directly to the UIM.

**4.4.4.2** An application to the UIM for grant or recognition of a *TUE* must be made as soon as possible, save where Articles 4.1 or 4.3 of the *International Standard for Therapeutic Use Exemptions* apply. The application shall be made in accordance with Article 6 of the *International Standard for Therapeutic Use Exemptions* as posted on the UIM's website.

**4.4.4.3** The UIM shall establish a *Therapeutic Use Exemption* Committee ("TUEC") to consider applications for the grant or recognition of *TUEs*. in accordance with Article 4.4.4.3(a)-(d) below:

- (a) The TUEC shall consist of a minimum of five (5) members with experience in the care and treatment of *Athletes* and sound knowledge of clinical, sports and exercise medicine. Each appointed member should serve a term of four (4) years which is renewable.
- (b) Before serving as a member of the TUEC, each member must sign a conflict of interest and confidentiality declaration. The appointed members shall not be employees of [IF]the UIM.
- (c) When an application to [IF]the UIM for the grant or recognition of a *TUE* is made, the Chair of the TUEC or the [IF]the UIM shall appoint three (3) members (which may include the Chair) to consider the application.
- (d) Before considering a *TUE* application, each member shall disclose any circumstances likely to affect their impartiality with respect to the *Athlete* making the application. If a member is unwilling or unable to assess the *Athlete's TUE* application, for any reason, the Chair or the [IF]the UIM shall appoint a replacement from the pool of members appointed under point (a) above. The Chair cannot serve as a member of the TUEC if there are any circumstances which are likely to affect the impartiality of the *TUE* decision.

**4.4.4.4** The TUEC shall promptly evaluate and decide upon the application in accordance with the relevant provisions of the

<sup>21</sup> [Comment to Article 4.4.4: The submission of falsified documents to a TUEC or the UIM, offering or accepting a bribe to a Person to perform or fail to perform an act, procuring false testimony from any witness, or committing any other fraudulent act or any other similar intentional interference or Attempted interference with any aspect of the TUE process shall result in a charge of Tampering or Attempted Tampering under Article 2.5.

An *Athlete* should not assume that their application for the grant or recognition of a *TUE* (or for renewal of a *TUE*) will be granted. Any Use or Possession or Administration of a Prohibited Substance or Prohibited Method before an application has been granted is entirely at the *Athlete's* own risk.]

*International Standard for Therapeutic Use Exemptions* and usually (i.e., unless exceptional circumstances apply) within no more than twenty-one (21) days of receipt of a complete application. Where the application is made in a reasonable time prior to an *Event*, the TUEC must use its best endeavors to issue its decision before the start of the *Event*.

**4.4.4.5** The TUEC decision shall be the final decision of the UIM and may be appealed in accordance with Article 4.4.7. the UIM TUEC decision shall be notified in writing to the *Athlete*, and to *WADA* and other *Anti-Doping Organizations* in accordance with the *International Standard for Therapeutic Use Exemptions*. It shall also promptly be reported into *ADAMS*.

**4.4.4.6** If the UIM (or the *National Anti-Doping Organization*, where it has agreed to consider the application on behalf of the UIM) denies the *Athlete's* application, it must notify the *Athlete* promptly, with reasons. If the UIM grants the *Athlete's* application, it must notify not only the *Athlete* but also their *National Anti-Doping Organization*. If the *National Anti-Doping Organization* considers that the *TUE* granted by the UIM does not meet the criteria set out in the *International Standard for Therapeutic Use Exemptions*, it has twenty-one (21) days from such notification to refer the matter to *WADA* for review in accordance with Article 4.4.7.

If the *National Anti-Doping Organization* refers the matter to *WADA* for review, the *TUE* granted by the UIM remains valid for international-level *Competition* and *Out-of-Competition Testing* (but is not valid for national-level *Competition*) pending *WADA's* decision. If the *National Anti-Doping Organization* does not refer the matter to *WADA* for review, the *TUE* granted by the UIM becomes valid for national-level *Competition* as well when the twenty-one (21) day review deadline expires.

#### **4.4.5** Retroactive *TUE* Applications

If the UIM chooses to collect a *Sample* from an *Athlete* who is not an *International-Level Athlete* or a *National-Level Athlete*, and that *Athlete* is *Using a Prohibited Substance or Prohibited Method* for therapeutic reasons, the UIM must permit that *Athlete* to apply for a retroactive *TUE*.

#### **4.4.6** Expiration, Withdrawal or Reversal of a *TUE*

**4.4.6.1** A *TUE* granted pursuant to these Anti-Doping Rules: (a) shall expire automatically at the end of any term for which it was granted, without the need for any further notice or other formality; (b) will be withdrawn if the *Athlete* does not promptly comply with any requirements or conditions imposed by the TUEC upon grant of the *TUE*; (c) may be withdrawn by the TUEC if it is subsequently determined that the criteria for grant of a *TUE* are not in fact met; or (d) may be reversed on review by *WADA* or on appeal.

**4.4.6.2** In such event, the *Athlete* shall not be subject to any *Consequences* based on their *Use* or *Possession* or *Administration* of the *Prohibited Substance* or *Prohibited Method* in question in accordance with the *TUE* prior to the effective date of expiry, withdrawal, or reversal of the *TUE*. The review pursuant to Article 5.1.1.1 of the *International Standard for Results Management* of an *Adverse Analytical Finding*, reported shortly after the *TUE* expiry, withdrawal or reversal, shall include consideration of whether such finding is consistent with *Use* of the

*Prohibited Substance or Prohibited Method* prior to that date, in which event no anti-doping rule violation shall be asserted.

#### 4.4.7 Reviews and Appeals of TUE Decisions

- 4.4.7.1** WADA must review the UIM's decision not to recognize a TUE granted by the *National Anti-Doping Organization* that is referred to WADA by the *Athlete* or the *Athlete's National Anti-Doping Organization*. In addition, WADA must review the UIM's decision to grant a TUE that is referred to WADA by the *Athlete's National Anti-Doping Organization*. WADA may review any other TUE decisions at any time, whether upon request by those affected or on its own initiative. If the TUE decision being reviewed meets the criteria set out in the *International Standard for Therapeutic Use Exemptions*, WADA will not interfere with it. If the TUE decision does not meet those criteria, WADA will reverse it.<sup>22</sup>
- 4.4.7.2** Any TUE decision by the UIM (or by a *National Anti-Doping Organization* where it has agreed to consider the application on behalf of the UIM) that is not reviewed by WADA, or that is reviewed by WADA but is not reversed upon review, may be appealed by the *Athlete* and/or the *Athlete's National Anti-Doping Organization*, exclusively to CAS.<sup>23</sup>
- 4.4.7.3** A decision by WADA to reverse a TUE decision may be appealed by the *Athlete*, the *National Anti-Doping Organization* and/or the UIM, exclusively to CAS.
- 4.4.7.4** A failure to render a decision within a reasonable time on a properly submitted application for grant/recognition of a TUE or for review of a TUE decision shall be considered a denial of the application thus triggering the applicable rights of review/appeal.

## ARTICLE 5 TESTING AND INVESTIGATIONS

### 5.1 Purpose of Testing and Investigations<sup>24</sup>

- 5.1.1** Testing and investigations may be undertaken for any anti-doping purpose. They shall be conducted in conformity with the provisions of the *International Standard for Testing and Investigations*.
- 5.1.2** Testing shall be undertaken to obtain analytical evidence as to whether the *Athlete* has violated Article 2.1 (Presence of a *Prohibited Substance* or its *Metabolites* or *Markers* in an *Athlete's Sample*) or Article 2.2 (*Use or Attempted Use* by an *Athlete* of a *Prohibited Substance* or a *Prohibited Method*).

<sup>22</sup> [Comment to Article 4.4.7.1: WADA shall be entitled to charge a fee to cover the costs of: (a) any review it is required to conduct in accordance with Article 4.4.7; and (b) any review it chooses to conduct, where the decision being reviewed is reversed.]

<sup>23</sup> [Comment to Article 4.4.7.2: In such cases, the decision being appealed is the UIM's TUE decision, not WADA's decision not to review the TUE decision or (having reviewed it) not to reverse the TUE decision. However, the time to appeal the TUE decision does not begin to run until the date that WADA communicates its decision. In any event, whether the decision has been reviewed by WADA or not, WADA shall be given notice of the appeal so that it may participate if it sees fit.]

<sup>24</sup> [Comment to Article 5.1: Where Testing is conducted for anti-doping purposes, the analytical results and data may be used for other legitimate purposes under the Anti-Doping Organization's rules. See, e.g., Comment to Article 23.2.2 of the Code.]

## 5.2 Authority to Test

- 5.2.1** Subject to the limitations for *Event Testing* set out in Article 5.3, the UIM shall have *In-Competition* and *Out-of-Competition Testing* authority over all *Athletes* specified in the Introduction to these Anti-Doping Rules (Section “Scope of these Anti-Doping Rules”).
- 5.2.2** The UIM may require any *Athlete* over whom it has *Testing* authority (including any *Athlete* serving a period of *Ineligibility*) to provide a *Sample* at any time and at any place.<sup>25</sup>
- 5.2.3** WADA shall have *In-Competition* and *Out-of-Competition Testing* authority as set out in Article 20.7.10 of the Code.
- 5.2.4** If the UIM delegates or contracts any part of *Testing* to a *National Anti-Doping Organization* directly or through a *National Authority*, that *National Anti-Doping Organization* may collect additional *Samples* or direct the laboratory to perform additional types of analysis at the *National Anti-Doping Organization’s* expense. If additional *Samples* are collected or additional types of analysis are performed, the UIM shall be notified.

## 5.3 Event Testing

- 5.3.1** Except as otherwise provided below, only a single organization shall have authority to conduct *Testing* at *Event Venues* during an *Event Period*. At *International Events*, the UIM (or other international organization which is the ruling body for an *Event*) shall have authority to conduct *Testing*. At *National Events*, the *National Anti-Doping Organization* of that country shall have authority to conduct *Testing*. At the request of the UIM (or other international organization which is the ruling body for an *Event*), any *Testing* during the *Event Period* outside of the *Event Venues* shall be coordinated with the UIM (or the relevant ruling body of the *Event*).
- 5.3.2** If an *Anti-Doping Organization*, which would otherwise have *Testing* authority but is not responsible for initiating and directing *Testing* at an *Event*, desires to conduct *Testing* of *Athletes* at the *Event Venues* during the *Event Period*, the *Anti-Doping Organization* shall first confer with the UIM (or other international organization which is the ruling body of the *Event*) to obtain permission to conduct and coordinate such *Testing*. If the *Anti-Doping Organization* is not satisfied with the response from the UIM (or other international organization which is the ruling body of the *Event*), the *Anti-Doping Organization* may, in accordance with the procedures described in the *International Standard for Testing and Investigations*, ask WADA for permission to conduct *Testing* and to determine how to coordinate such *Testing*. WADA shall not grant approval for such *Testing* before consulting with and informing the UIM (or other international organization which is the ruling body for the *Event*). WADA’s decision shall be final and not subject to appeal. Unless otherwise provided in the authorization to conduct *Testing*, such tests shall be considered *Out-of-Competition* tests. *Results Management* for any such test shall be the responsibility of the *Anti-Doping*

<sup>25</sup> [Comment to Article 5.2.2: the UIM may obtain additional authority to conduct *Testing* by means of bilateral or multilateral agreements with other Signatories. Unless the *Athlete* has identified a sixty (60) minute *Testing* window between the hours of 11:00 p.m. and 6:00 a.m., or has otherwise consented to *Testing* during that period, the UIM will not test an *Athlete* during that period unless it has a serious and specific suspicion that the *Athlete* may be engaged in doping. A challenge to whether the UIM had sufficient suspicion for *Testing* during this time period shall not be a defense to an anti-doping rule violation based on such test or attempted test.]

*Organization* initiating the test unless provided otherwise in the rules of the ruling body of the *Event*.<sup>26</sup>

#### 5.4 Testing Requirements

- 5.4.1 The UIM shall conduct test distribution planning and *Testing* as required by the *International Standard* for *Testing* and Investigations.
- 5.4.2 Where reasonably feasible, *Testing* shall be coordinated through ADAMS in order to maximize the effectiveness of the combined *Testing* effort and to avoid unnecessary repetitive *Testing*.

#### 5.5 Athlete Whereabouts Information

- 5.5.1 The UIM may establish a *Registered Testing Pool* of those *Athletes* who are required to provide whereabouts information in the manner specified in the *International Standard* for *Testing* and Investigations and who shall be subject to *Consequences* for Article 2.4 violations as provided in Article 10.3.2. the UIM shall coordinate with *National Anti-Doping Organizations* to identify such *Athletes* and to collect their whereabouts information.
- 5.5.2 The UIM shall make available through ADAMS a list which identifies those *Athletes* included in its *Registered Testing Pool* by name. the UIM shall regularly review and update as necessary its criteria for including *Athletes* in its *Registered Testing Pool*, and shall periodically (but not less than quarterly) review the list of *Athletes* in its *Registered Testing Pool* to ensure that each listed *Athlete* continues to meet the relevant criteria. *Athletes* shall be notified before they are included in the *Registered Testing Pool* and when they are removed from that pool. The notification shall contain the information set out in the *International Standard* for *Testing* and Investigations.
- 5.5.3 Where an *Athlete* is included in an international *Registered Testing Pool* by the UIM and in a national *Registered Testing Pool* by their *National Anti-Doping Organization*, the *National Anti-Doping Organization* and the UIM shall agree between themselves which of them shall accept that *Athlete's* whereabouts filings; in no case shall an *Athlete* be required to make whereabouts filings to more than one of them.
- 5.5.4 In accordance with the *International Standard* for *Testing* and Investigations, each *Athlete* in the *Registered Testing Pool* shall do the following: (a) advise the UIM of his/her whereabouts on a quarterly basis; (b) update that information as necessary so that it remains accurate and complete at all times; and (c) make himself or herself available for *Testing* at such whereabouts.
- 5.5.5 For purposes of Article 2.4, an *Athlete's* failure to comply with the requirements of the *International Standard* for *Testing* and Investigations shall be deemed a filing failure or a missed test, as defined in Annex B of the *International Standard* for *Results Management*, where the conditions set forth in Annex B are met.
- 5.5.6 An *Athlete* in the UIM's *Registered Testing Pool* shall continue to be subject to the obligation to comply with the whereabouts requirements set in the *International Standard* for *Testing* and Investigations unless and until (a) the

<sup>26</sup> [Comment to Article 5.3.2: Before giving approval to a National Anti-Doping Organization to initiate and conduct *Testing* at an International Event, WADA shall consult with the international organization which is the ruling body for the Event. Before giving approval to an International Federation to initiate and conduct *Testing* at a National Event, WADA shall consult with the National Anti-Doping Organization of the country where the Event takes place. The Anti-Doping Organization "initiating and directing *Testing*" may, if it chooses, enter into agreements with a Delegated Third Party to which it delegates responsibility for Sample collection or other aspects of the Doping Control process.]

*Athlete* gives written notice to the UIM that he or she has retired or (b) the UIM has informed him or her that he or she no longer satisfies the criteria for inclusion in the UIM's *Registered Testing Pool*.

- 5.5.7** Whereabouts information provided by an *Athlete* while in the *Registered Testing Pool* will be accessible through ADAMS to WADA and to other *Anti-Doping Organizations* having authority to test that *Athlete* as provided in Article 5.2. Whereabouts information shall be maintained in strict confidence at all times; it shall be used exclusively for purposes of planning, coordinating or conducting *Doping Control*, providing information relevant to the *Athlete Biological Passport* or other analytical results, to support an investigation into a potential anti-doping rule violation, or to support proceedings alleging an anti-doping rule violation; and shall be destroyed after it is no longer relevant for these purposes in accordance with the *International Standard* for the Protection of Privacy and Personal Information.
- 5.5.8** The UIM may, in accordance with the *International Standard for Testing and Investigations*, collect whereabouts information from *Athletes* who are not included within a *Registered Testing Pool*. If it chooses to do so, an *Athlete's* failure to provide requested whereabouts information on or before the date required by the UIM or the *Athlete's* failure to provide accurate whereabouts information may result in consequences defined in Article 5.5.12 below (if one established).
- 5.5.9** In accordance with the *International Standard for Testing and Investigations*, the UIM may establish a *Testing Pool*, which includes *Athletes* who are subject to less stringent whereabouts requirements than *Athletes* included in the UIM's *Registered Testing Pool*.
- 5.5.10** The UIM shall notify *Athletes* before they are included in the *Testing Pool* and when they are removed. Such notification shall include the whereabouts requirements and the consequences that apply in case of non-compliance, as indicated in Articles 5.5.11 and 5.5.12.
- 5.5.11** *Athletes* included in the *Testing Pool* shall provide the UIM at least with the following whereabouts information so that they may be located and subjected to *Testing*:
- (a) An overnight address;
  - (b) Competition / Event schedule; and
  - (c) Regular training activities.
- Such whereabouts information shall be filed in ADAMS to enable better *Testing* coordination with other *Anti-Doping Organizations*.
- 5.5.12** An *Athlete's* failure to provide whereabouts information on or before the date required by the UIM or the *Athlete's* failure to provide accurate whereabouts information may result in the UIM elevating the *Athlete* to the UIM's *Registered Testing Pool* (if one established) and additional appropriate and proportionate non-Code Article 2.4 consequences, established by the UIM if any.

## **5.6 Retired Athletes Returning to Competition**

- 5.6.1** If an *International-Level Athlete* or *National-Level Athlete* in the UIM's *Registered Testing Pool* retires and then wishes to return to active participation in sport, the *Athlete* shall not compete in *International Events* or *National Events* until the *Athlete* has made himself or herself available for *Testing*, by giving six (6) months prior written notice to the UIM and their *National Anti-Doping Organization*.

WADA, in consultation with the UIM and the *Athlete's National Anti-Doping Organization*, may grant an exemption to the six (6) month written notice rule where the strict application of that rule would be unfair to the *Athlete*. This decision may be appealed under Article 13.<sup>27</sup>

Any competitive results obtained in violation of this Article 5.6.1 shall be *Disqualified* unless the *Athlete* can establish that he or she could not have reasonably known that this was an *International Event* or a *National Event*.

- 5.6.2** If an *Athlete* retires from sport while subject to a period of *Ineligibility*, the *Athlete* must notify the *Anti-Doping Organization* that imposed the period of *Ineligibility* in writing of such retirement. If the *Athlete* then wishes to return to active competition in sport, the *Athlete* shall not compete in *International Events* or *National Events* until the *Athlete* has made himself or herself available for *Testing* by giving six (6) months prior written notice (or notice equivalent to the period of *Ineligibility* remaining as of the date the *Athlete* retired, if that period was longer than six (6) months) to the UIM and to their *National Anti-Doping Organization*.

## 5.7 Independent Observer Program

The UIM and the organizing committees for the UIM's *Events*, as well as the *National Authorities* and the organizing committees for *National Events*, shall authorize and facilitate the *Independent Observer Program* at such *Events*.

## ARTICLE 6 ANALYSIS OF SAMPLES

*Samples* shall be analysed in accordance with the following principles:

### 6.1 Use of Accredited, Approved Laboratories and Other Laboratories

- 6.1.1** For purposes of directly establishing an *Adverse Analytical Finding* under Article 2.1, *Samples* shall be analysed only in WADA-accredited laboratories or laboratories otherwise approved by WADA. The choice of the WADA-accredited or WADA-approved laboratory used for the *Sample* analysis shall be determined exclusively by the UIM.<sup>28</sup>
- 6.1.2** As provided in Article 3.2, facts related to anti-doping rule violations may be established by any reliable means. This would include, for example, reliable laboratory or other forensic testing conducted outside of WADA-accredited or approved laboratories.

### 6.2 Purpose of Analysis of Samples and Data

*Samples* and related analytical data or *Doping Control* information shall be analysed to detect *Prohibited Substances* and *Prohibited Methods* identified on the *Prohibited List* and other substances as may be directed by WADA pursuant to the monitoring program described in Article 4.5 of the *Code*, or to assist the UIM in profiling relevant parameters in an *Athlete's* urine, blood or other matrix, including for DNA or genomic profiling, or for any other legitimate anti-doping purpose.<sup>29</sup>

<sup>27</sup> [Comment to Article 5.6.1: WADA has developed a [protocol and exemption application form](#) that Athletes must use to make such requests, and a [decision template](#) that the International Federations must use. Both documents are available on WADA's website at <https://www.wada-ama.org>.]

<sup>28</sup> [Comment to Article 6.1: Violations of Article 2.1 may be established only by Sample analysis performed by a WADA-accredited laboratory or another laboratory approved by WADA. Violations of other Articles may be established using analytical results from other laboratories so long as the results are reliable.]

<sup>29</sup> [Comment to Article 6.2: For example, relevant Doping Control-related information could be used to direct Target Testing or to support an anti-doping rule violation proceeding under Article 2.2, or both.]

### 6.3 Research on *Samples* and Data

*Samples*, related analytical data and *Doping Control* information may be used for anti-doping research purposes, although no *Sample* may be used for research without the *Athlete's* written consent. *Samples* and related analytical data or *Doping Control* information used for research purposes shall first be processed in such a manner as to prevent *Samples* and related analytical data or *Doping Control* information being traced back to a particular *Athlete*. Any research involving *Samples* and related analytical data or *Doping Control* information shall adhere to the principles set out in Article 19 of the *Code*.<sup>30</sup>

### 6.4 Standards for *Sample* Analysis and Reporting

In accordance with Article 6.4 of the *Code*, the UIM shall ask laboratories to analyse *Samples* in conformity with the *International Standard* for Laboratories and Article 4.7 of the *International Standard* for Testing and Investigations.

Laboratories at their own initiative and expense may analyse *Samples* for *Prohibited Substances* or *Prohibited Methods* not included on the standard *Sample* analysis menu, or as requested by the UIM. Results from any such analysis shall be reported to the UIM and have the same validity and *Consequences* as any other analytical result.<sup>31</sup>

### 6.5 Further Analysis of a *Sample* Prior to or During *Results Management*

There shall be no limitation on the authority of a laboratory to conduct repeat or additional analysis on a *Sample* prior to the time the UIM notifies an *Athlete* that the *Sample* is the basis for an Article 2.1 anti-doping rule violation charge. If after such notification the UIM wishes to conduct additional analysis on that *Sample*, it may do so with the consent of the *Athlete* or approval from a hearing body.

### 6.6 Further Analysis of a *Sample* After it has been Reported as Negative or has Otherwise not Resulted in an Anti-Doping Rule Violation Charge

After a laboratory has reported a *Sample* as negative, or the *Sample* has not otherwise resulted in an anti-doping rule violation charge, it may be stored and subjected to further analyses for the purpose of Article 6.2 at any time exclusively at the direction of either the *Anti-Doping Organization* that initiated and directed *Sample* collection or WADA. Any other *Anti-Doping Organization* with authority to test the *Athlete* that wishes to conduct further analysis on a stored *Sample* may do so with the permission of the *Anti-Doping Organization* that initiated and directed *Sample* collection or WADA, and shall be responsible for any follow-up *Results Management*. Any *Sample* storage or further analysis initiated by WADA or another *Anti-Doping Organization* shall be at WADA's or that organization's expense. Further analysis of *Samples* shall conform with the requirements of the *International Standard* for Laboratories.

### 6.7 Split of A or B *Sample*

Where WADA, an *Anti-Doping Organization* with *Results Management* authority, and/or a WADA-accredited laboratory (with approval from WADA or the *Anti-Doping Organization* with *Results Management* authority) wishes to split an A or B *Sample* for the purpose of using the

<sup>30</sup> [Comment to Article 6.3: As is the case in most medical or scientific contexts, use of *Samples* and related information for quality assurance, quality improvement, method improvement and development or to establish reference populations is not considered research. *Samples* and related information used for such permitted non-research purposes must also first be processed in such a manner as to prevent them from being traced back to the particular *Athlete*, having due regard to the principles set out in Article 19 of the *Code*, as well as the requirements of the *International Standard* for Laboratories and *International Standard* for the Protection of Privacy and Personal Information.]

<sup>31</sup> [Comment to Article 6.4: The objective of this Article is to extend the principle of "Intelligent Testing" to the *Sample* analysis menu so as to most effectively and efficiently detect doping. It is recognized that the resources available to fight doping are limited and that increasing the *Sample* analysis menu may, in some sports and countries, reduce the number of *Samples* which can be analysed.]

first part of the split *Sample* for an A *Sample* analysis and the second part of the split *Sample* for confirmation, then the procedures set forth in the *International Standard* for Laboratories shall be followed.

## 6.8 WADA's Right to Take Possession of Samples and Data

WADA may, in its sole discretion at any time, with or without prior notice, take physical possession of any *Sample* and related analytical data or information in the possession of a laboratory or *Anti-Doping Organization*. Upon request by WADA, the laboratory or *Anti-Doping Organization* in possession of the *Sample* or data shall immediately grant access to and enable WADA to take physical possession of the *Sample* or data. If WADA has not provided prior notice to the laboratory or *Anti-Doping Organization* before taking possession of a *Sample* or data, it shall provide such notice to the laboratory and each *Anti-Doping Organization* whose *Samples* or data have been taken by WADA within a reasonable time after taking possession. After analysis and any investigation of a seized *Sample* or data, WADA may direct another *Anti-Doping Organization* with authority to test the *Athlete* to assume *Results Management* responsibility for the *Sample* or data if a potential anti-doping rule violation is discovered.<sup>32</sup>

## ARTICLE 7 RESULTS MANAGEMENT: RESPONSIBILITY, INITIAL REVIEW, NOTICE AND PROVISIONAL SUSPENSIONS

*Results Management* under these Anti-Doping Rules establishes a process designed to resolve anti-doping rule violation matters in a fair, expeditious and efficient manner.

### 7.1 Responsibility for Conducting Results Management

- 7.1.1** Except as otherwise provided in Articles 6.6, 6.8 and Code Article 7.1, *Results Management* shall be the responsibility of, and shall be governed by, the procedural rules of the *Anti-Doping Organization* that initiated and directed *Sample* collection (or, if no *Sample* collection is involved, the *Anti-Doping Organization* which first provides notice to an *Athlete* or other Person of a potential anti-doping rule violation and then diligently pursues that anti-doping rule violation).
- 7.1.2** In circumstances where the rules of a *National Anti-Doping Organization* do not give the *National Anti-Doping Organization* authority over an *Athlete* or other Person who is not a national, resident, license holder, or member of a sport organization of that country, or the *National Anti-Doping Organization* declines to exercise such authority, *Results Management* shall be conducted by the applicable International Federation or by a third party with authority over the *Athlete* or other Person as directed by the rules of the applicable International Federation.
- 7.1.3** In the event the *Major Event Organization* assumes only limited *Results Management* responsibility relating to a *Sample* initiated and taken during an *Event* conducted by a *Major Event Organization*, or an anti-doping rule violation occurring during such *Event*, the case shall be referred by the *Major Event Organization* to the applicable International Federation for completion of *Results Management*.

<sup>32</sup> [Comment to Article 6.8: Resistance or refusal to WADA taking physical possession of Samples or data could constitute Tampering, Complicity or an act of non-compliance as provided in the International Standard for Code Compliance by Signatories, and could also constitute a violation of the International Standard for Laboratories. Where necessary, the laboratory and/or the Anti-Doping Organization shall assist WADA in ensuring that the seized Sample or data are not delayed in exiting the applicable country.]

WADA would not, of course, unilaterally take possession of Samples or analytical data without good cause related to a potential anti-doping rule violation, non-compliance by a Signatory or doping activities by another Person. However, the decision as to whether good cause exists is for WADA to make in its discretion and shall not be subject to challenge. In particular, whether there is good cause or not shall not be a defense against an anti-doping rule violation or its Consequences.]

- 7.1.4** *Results Management* in relation to a potential whereabouts failure (a filing failure or a missed test) shall be administered by the UIM or the *National Anti-Doping Organization* with whom the *Athlete* in question files whereabouts information, as provided in the *International Standard for Results Management*. If the UIM determines a filing failure or a missed test, it shall submit that information to *WADA* through *ADAMS*, where it will be made available to other relevant *Anti-Doping Organizations*.
- 7.1.5** Other circumstances in which the UIM shall take responsibility for conducting *Results Management* in respect of anti-doping rule violations involving *Athletes* and other *Persons* under its authority shall be determined by reference to and in accordance with Article 7 of the *Code*.
- 7.1.6** *WADA* may direct the UIM to conduct *Results Management* in particular circumstances. If the UIM refuses to conduct *Results Management* within a reasonable deadline set by *WADA*, such refusal shall be considered an act of non-compliance, and *WADA* may direct another *Anti-Doping Organization* with authority over the *Athlete* or other *Person*, that is willing to do so, to take *Results Management* responsibility in place of the UIM or, if there is no such *Anti-Doping Organization*, any other *Anti-Doping Organization* that is willing to do so. In such case, the UIM shall reimburse the costs and attorney's fees of conducting *Results Management* to the other *Anti-Doping Organization* designated by *WADA*, and a failure to reimburse costs and attorney's fees shall be considered an act of non-compliance.

## **7.2 Review and Notification Regarding Potential Anti-Doping Rule Violations**

The UIM shall carry out the review and notification with respect to any potential anti-doping rule violation in accordance with the *International Standard for Results Management*.

## **7.3 Identification of Prior Anti-Doping Rule Violations**

Before giving an *Athlete* or other *Person* notice of a potential anti-doping rule violation as provided above, the UIM shall refer to *ADAMS* and contact *WADA* and other relevant *Anti-Doping Organizations* to determine whether any prior anti-doping rule violation exists.

## **7.4 Provisional Suspensions**<sup>33</sup>

### **7.4.1 Mandatory Provisional Suspension after an Adverse Analytical Finding or Adverse Passport Finding**

If the UIM receives an *Adverse Analytical Finding* or an *Adverse Passport Finding* (upon completion of the *Adverse Passport Finding* review process) for a *Prohibited Substance* or a *Prohibited Method* that is not a *Specified Substance* or a *Specified Method*, the UIM shall impose a *Provisional Suspension* on the *Athlete* promptly upon or after the review and notification required by Article 7.2.

A mandatory *Provisional Suspension* may be eliminated if: (i) the *Athlete* demonstrates to the UIM Anti-Doping Hearing Panel that the violation is likely to have involved a *Contaminated Product*, or (ii) the violation involves a *Substance of Abuse* and the *Athlete* establishes entitlement to a reduced period of *Ineligibility* under Article 10.2.4.1.

The UIM Anti-Doping Hearing Panel's decision not to eliminate a mandatory *Provisional Suspension* on account of the *Athlete's* assertion regarding a *Contaminated Product* shall not be appealable.

<sup>33</sup> [Comment to Article 7.4: Before a *Provisional Suspension* can be unilaterally imposed by the UIM, the internal review specified in these *Anti-Doping Rules* and the *International Standard for Results Management* must first be completed.]

**7.4.2** Optional *Provisional Suspension* Based on an *Adverse Analytical Finding* for *Specified Substances, Specified Methods, Contaminated Products, or Other Anti-Doping Rule Violations*

The UIM may impose a *Provisional Suspension* for anti-doping rule violations not covered by Article 7.4.1 prior to the analysis of the *Athlete's B Sample* or final hearing as described in Article 8.

An optional *Provisional Suspension* may be lifted at the discretion of the UIM at any time prior to the UIM Anti-Doping Hearing Panel's decision under Article 8, unless provided otherwise in the *International Standard for Results Management*.

**7.4.3** Opportunity for Hearing or Appeal

Notwithstanding Articles 7.4.1 and 7.4.2, a *Provisional Suspension* may not be imposed unless the *Athlete* or other *Person* is given: (a) an opportunity for a *Provisional Hearing*, either before or on a timely basis after imposition of the *Provisional Suspension*; or (b) an opportunity for an expedited hearing in accordance with Article 8 on a timely basis after imposition of the *Provisional Suspension*.

The imposition of a *Provisional Suspension*, or the decision not to impose a *Provisional Suspension*, may be appealed in an expedited process in accordance with Article 13.2.

**7.4.4** Voluntary Acceptance of *Provisional Suspension*

*Athletes* on their own initiative may voluntarily accept a *Provisional Suspension* if done so prior to the later of: (i) the expiration of ten (10) days from the report of the *B Sample* (or waiver of the *B Sample*) or ten (10) days from the notice of any other anti-doping rule violation, or (ii) the date on which the *Athlete* first competes after such report or notice.

Other *Persons* on their own initiative may voluntarily accept a *Provisional Suspension* if done so within ten (10) days from the notice of the anti-doping rule violation.

Upon such voluntary acceptance, the *Provisional Suspension* shall have the full effect and be treated in the same manner as if the *Provisional Suspension* had been imposed under Article 7.4.1 or 7.4.2; provided, however, at any time after voluntarily accepting a *Provisional Suspension*, the *Athlete* or other *Person* may withdraw such acceptance, in which event the *Athlete* or other *Person* shall not receive any credit for time previously served during the *Provisional Suspension*.

**7.4.5** If a *Provisional Suspension* is imposed based on an *A Sample Adverse Analytical Finding* and a subsequent *B Sample* analysis (if requested by the *Athlete* or the UIM) does not confirm the *A Sample* analysis, then the *Athlete* shall not be subject to any further *Provisional Suspension* on account of a violation of Article 2.1. In circumstances where the *Athlete* (or the *Athlete's* team has been removed from an *Event* based on a violation of Article 2.1 and the subsequent *B Sample* analysis does not confirm the *A Sample* finding, then, if it is still possible for the *Athlete* or team to be reinserted, without otherwise affecting the *Event*, the *Athlete* or team may continue to take part in the *Event*.

**7.5 Results Management Decisions**

*Results Management* decisions or adjudications by the UIM must not purport to be limited to a particular geographic area or the UIM's sport and shall address and determine without

limitation the following issues: (i) whether an anti-doping rule violation was committed or a *Provisional Suspension* should be imposed, the factual basis for such determination, and the specific Articles that have been violated, and (ii) all *Consequences* flowing from the anti-doping rule violation(s), including applicable *Disqualifications* under Articles 9 and 10.10, any forfeiture of medals or prizes, any period of *Ineligibility* (and the date it begins to run) and any *Financial Consequences*.<sup>34</sup>

## 7.6 Notification of Results Management Decisions

The UIM shall notify *Athletes*, other *Persons*, *Signatories* and *WADA* of *Results Management* decisions as provided in Article 14.2 and in the *International Standard for Results Management*.

## 7.7 Retirement from Sport<sup>35</sup>

If an *Athlete* or other *Person* retires while the UIM's *Results Management* process is underway, the UIM retains authority to complete its *Results Management* process. If an *Athlete* or other *Person* retires before any *Results Management* process has begun, and the UIM would have had *Results Management* authority over the *Athlete* or other *Person* at the time the *Athlete* or other *Person* committed an anti-doping rule violation, the UIM has authority to conduct *Results Management*.

# ARTICLE 8 RESULTS MANAGEMENT: RIGHT TO A FAIR HEARING AND NOTICE OF HEARING DECISION

For any *Person* who is asserted to have committed an anti-doping rule violation, the UIM shall provide a fair hearing within a reasonable time by a fair, impartial and *Operationally Independent* hearing panel in compliance with the *Code* and the *International Standard for Results Management*.

## 8.1 Fair Hearings

### 8.1.1 Fair, Impartial and Operationally Independent Hearing Panel

**8.1.1.1** The UIM shall establish a Hearing Panel [the UIM Anti-Doping Hearing Panel] which has jurisdiction to hear and determine whether an *Athlete* or other *Person*, subject to these Anti-Doping Rules, has committed an anti-doping rule violation and, if applicable, to impose relevant *Consequences*.

**8.1.1.2** The UIM shall ensure that the UIM Anti-Doping Hearing Panel is free of conflict of interest and that its composition, term of office,

<sup>34</sup> [Comment to Article 7.5: Results Management decisions include Provisional Suspensions.]

Each decision by the UIM should address whether an anti-doping rule violation was committed and all Consequences flowing from the violation, including any Disqualifications other than Disqualification under Article 10.1 (which is left to the ruling body for an Event). Pursuant to Article 15, such decision and its imposition of Consequences shall have automatic effect in every sport in every country. For example, for a determination that an Athlete committed an anti-doping rule violation based on an Adverse Analytical Finding for a Sample taken In-Competition, the Athlete's results obtained in the Competition would be Disqualified under Article 9 and all other competitive results obtained by the Athlete from the date the Sample was collected through the duration of the period of Ineligibility are also Disqualified under Article 10.10; if the Adverse Analytical Finding resulted from Testing at an Event, it would be the Major Event Organization's responsibility to decide whether the Athlete's other individual results in the Event prior to Sample collection are also Disqualified under Article 10.1.]

<sup>35</sup> [Comment to Article 7.7: Conduct by an Athlete or other Person before the Athlete or other Person was subject to the authority of any Anti-Doping Organization would not constitute an anti-doping rule violation but could be a legitimate basis for denying the Athlete or other Person membership in a sports organization.]

professional experience, *Operational Independence* and adequate financing comply with the requirements of the *International Standard for Results Management*.

- 8.1.1.3** Board members, staff members, commission members, consultants and officials of the UIM or its affiliates (e.g. *National Authorities* or confederation), as well as any *Person* involved in the investigation and pre-adjudication of the matter, cannot be appointed as members and/or clerks (to the extent that such clerk is involved in the deliberation process and/or drafting of any decision) of the UIM Anti-Doping Hearing Panel. In particular, no member shall have previously considered any *TUE* application, *Results Management* decision, or appeals in the same given case.
- 8.1.1.4** The UIM Anti-Doping Hearing Panel shall consist of an independent Chair and two (2) other independent members.
- 8.1.1.5** Each member shall be appointed by taking into consideration their requisite anti-doping experience including their legal, sports, medical and/or scientific expertise. Each member shall be appointed for a once renewable term of three (3) years.
- 8.1.1.6** The UIM Anti-Doping Hearing Panel shall be in a position to conduct the hearing and decision-making process without interference from the UIM or any third party.

## **8.1.2** Hearing Process

- 8.1.2.1** When the UIM sends a notice to an *Athlete* or other *Person* notifying them of a potential anti-doping rule violation, and the *Athlete* or other *Person* does not waive a hearing in accordance with Article 8.3.1 or Article 8.3.2, then the case shall be referred to the UIM Anti-Doping Hearing Panel for hearing and adjudication, which shall be conducted in accordance with the principles described in Articles 8 and 9 of the *International Standard for Results Management*.
- 8.1.2.2** The Chair shall appoint three (3) members (which may include the Chair) to hear that case. When hearing a case, one (1) panel member shall be a qualified lawyer, with no less than three (3) years of relevant legal experience, and one (1) panel member shall be a qualified medical practitioner, with no less than three (3) years of relevant medical experience.
- 8.1.2.3** Upon appointment by the Chair as a member of the UIM Anti-Doping Hearing Panel, each member must also sign a declaration that there are no facts or circumstances known to him or her which might call into question their impartiality in the eyes of any of the parties, other than those circumstances disclosed in the declaration.
- 8.1.2.4** Hearings held in connection with *Events* in respect to *Athletes* and other *Persons* who are subject to these Anti-Doping Rules may be conducted by an expedited process where permitted by the UIM Anti-Doping Hearing Panel.<sup>36</sup>
- 8.1.2.5** *WADA*, the *National Authority* and the *National Anti-Doping Organization* of the *Athlete* or other *Person* may attend the hearing

<sup>36</sup> [Comment to Article 8.1.2.4: For example, a hearing could be expedited on the eve of a major Event where the resolution of the anti-doping rule violation is necessary to determine the Athlete's eligibility to participate in the Event, or during an Event where the resolution of the case will affect the validity of the Athlete's results or continued participation in the Event.]

as observers. In any event, the UIM shall keep them fully apprised as to the status of pending cases and the result of all hearings.

## 8.2 Notice of Decisions

- 8.2.1** At the end of the hearing, or promptly thereafter, the UIM Anti-Doping Hearing Panel shall issue a written decision that conforms with Article 9 of the *International Standard for Results Management* and which includes the full reasons for the decision, the period of *Ineligibility* imposed, the *Disqualification* of results under Article 10.10 and, if applicable, a justification for why the greatest potential *Consequences* were not imposed.
- 8.2.2** The UIM shall notify that decision to the *Athlete* or other *Person* and to other *Anti-Doping Organizations* with a right to appeal under Article 13.2.3, and shall promptly report it into *ADAMS*. The decision may be appealed as provided in Article 13.

## 8.3 Waiver of Hearing

- 8.3.1** An *Athlete* or other *Person* against whom an anti-doping violation is asserted may waive a hearing expressly and agree with the *Consequences* proposed by the UIM.
- 8.3.2** However, if the *Athlete* or other *Person* against whom an anti-doping rule violation is asserted fails to dispute that assertion within twenty (20) days or the deadline otherwise specified in the notice sent by the UIM asserting the violation, then they shall be deemed to have waived a hearing, to have admitted the violation, and to have accepted the proposed *Consequences*.
- 8.3.3** In cases where Article 8.3.1 or 8.3.2 applies, a hearing before the UIM Anti-Doping Hearing Panel shall not be required. Instead the UIM shall promptly issue a written decision that conforms with Article 9 of the *International Standard for Results Management* and which includes the full reasons for the decision, the period of *Ineligibility* imposed, the *Disqualification* of results under Article 10.10 and, if applicable, a justification for why the greatest potential *Consequences* were not imposed.
- 8.3.4** The UIM shall notify that decision to the *Athlete* or other *Person* and to other *Anti-Doping Organizations* with a right to appeal under Article 13.2.3, and shall promptly report it into *ADAMS*. The UIM shall *Publicly Disclose* that decision in accordance with Article 14.3.2.

## 8.4 Single Hearing Before CAS

Anti-doping rule violations asserted against *International-Level Athletes*, *National-Level Athletes* or other *Persons* may, with the consent of the *Athlete* or other *Person*, the UIM (where it has *Results Management* responsibility in accordance with Article 7) and WADA, be heard in a single hearing directly at CAS.<sup>37</sup>

<sup>37</sup> [Comment to Article 8.4: In some cases, the combined cost of holding a hearing in the first instance at the international or national level, then rehearing the case de novo before CAS can be very substantial. Where all of the parties identified in this Article are satisfied that their interests will be adequately protected in a single hearing, there is no need for the Athlete or Anti-Doping Organizations to incur the extra expense of two (2) hearings. An Anti-Doping Organization may participate in the CAS hearing as an observer Nothing set out in Article 8.4 precludes the Athlete or other Person and the UIM (where it has Results Management responsibility) to waive their right to appeal by agreement. Such waiver, however, only binds the parties to such agreement and not any other entity with a right of appeal under the Code.]

## ARTICLE 9 AUTOMATIC DISQUALIFICATION OF INDIVIDUAL RESULTS

An anti-doping rule violation in *Individual Sports* in connection with an *In-Competition* test automatically leads to *Disqualification* of the result obtained in that *Competition* with all resulting *Consequences*, including forfeiture of any medals, points and prizes.<sup>38</sup>

## ARTICLE 10 SANCTIONS ON INDIVIDUALS

### 10.1 *Disqualification of Results in the Event during which an Anti-Doping Rule Violation Occurs*

- 10.1.1** An anti-doping rule violation occurring during or in connection with an *Event* may, upon the decision of the ruling body of the *Event*, lead to *Disqualification* of all of the *Athlete's* individual results obtained in that *Event* with all *Consequences*, including forfeiture of all medals, points and prizes, except as provided in Article 10.1.2.

Factors to be included in considering whether to *Disqualify* other results in an *Event* might include, for example, the seriousness of the *Athlete's* anti-doping rule violation and whether the *Athlete* tested negative in the other *Competitions*.<sup>39</sup>

- 10.1.2** If the *Athlete* establishes that he or she bears *No Fault* or *Negligence* for the violation, the *Athlete's* individual results in the other *Competitions* shall not be *Disqualified*, unless the *Athlete's* results in *Competitions* other than the *Competition* in which the anti-doping rule violation occurred were likely to have been affected by the *Athlete's* anti-doping rule violation.

### 10.2 *Ineligibility for Presence, Use or Attempted Use, or Possession of a Prohibited Substance or Prohibited Method*

The period of *Ineligibility* for a violation of Article 2.1, 2.2 or 2.6 shall be as follows, subject to potential elimination, reduction or suspension pursuant to Article 10.5, 10.6 or 10.7:

- 10.2.1** The period of *Ineligibility*, subject to Article 10.2.4, shall be four (4) years where:
- 10.2.1.1** The anti-doping rule violation does not involve a *Specified Substance* or a *Specified Method*, unless the *Athlete* or other *Person* can establish that the anti-doping rule violation was not intentional.<sup>40</sup>

<sup>38</sup> [Comment to Article 9: For Team Sports, any awards received by individual players will be Disqualified. However, Disqualification of the team will be as provided in Article 11. In sports which are not Team Sports but where awards are given to teams, Disqualification or other disciplinary action against the team when one or more team members have committed an anti-doping rule violation shall be as provided in the applicable rules of the International Federation.]

<sup>39</sup> [Comment to Article 10.1.1: Whereas Article 9 Disqualifies the result in a single Competition in which the Athlete tested positive (e.g., the 100 meter backstroke), this Article may lead to Disqualification of all results in all races during the Event (e.g., the swimming World Championships).]

<sup>40</sup> [Comment to Article 10.2.1.1: While it is theoretically possible for an Athlete or other Person to establish that the anti-doping rule violation was not intentional without showing how the Prohibited Substance entered one's system, it is highly unlikely that in a doping case under Article 2.1 an Athlete will be successful in proving that the Athlete acted unintentionally without establishing the source of the Prohibited Substance.]

- 10.2.1.2** The anti-doping rule violation involves a *Specified Substance* or a *Specified Method* and the UIM can establish that the anti-doping rule violation was intentional.
- 10.2.2** If Article 10.2.1 does not apply, subject to Article 10.2.4.1, the period of *Ineligibility* shall be two (2) years.
- 10.2.3** As used in Article 10.2, the term “intentional” is meant to identify those *Athletes* or other *Persons* who engage in conduct which they knew constituted an anti-doping rule violation or knew that there was a significant risk that the conduct might constitute or result in an anti-doping rule violation and manifestly disregarded that risk. An anti-doping rule violation resulting from an *Adverse Analytical Finding* for a substance which is only prohibited *In-Competition* shall be rebuttably presumed to be not “intentional” if the substance is a *Specified Substance* and the *Athlete* can establish that the *Prohibited Substance* was *Used Out-of-Competition*. An anti-doping rule violation resulting from an *Adverse Analytical Finding* for a substance which is only prohibited *In-Competition* shall not be considered “intentional” if the substance is not a *Specified Substance* and the *Athlete* can establish that the *Prohibited Substance* was *Used Out-of-Competition* in a context unrelated to sport performance.<sup>41</sup>
- 10.2.4** Notwithstanding any other provision in Article 10.2, where the anti-doping rule violation involves a *Substance of Abuse*:
- 10.2.4.1** If the *Athlete* can establish that any ingestion or *Use* occurred *Out-of-Competition* and was unrelated to sport performance, then the period of *Ineligibility* shall be three (3) months *Ineligibility*.
- In addition, the period of *Ineligibility* calculated under this Article 10.2.4.1 may be reduced to one (1) month if the *Athlete* or other *Person* satisfactorily completes a *Substance of Abuse* treatment program approved by the UIM. The period of *Ineligibility* established in this Article 10.2.4.1 is not subject to any reduction based on any provision in Article 10.6.<sup>42</sup>
- 10.2.4.2** If the ingestion, *Use* or *Possession* occurred *In-Competition*, and the *Athlete* can establish that the context of the ingestion, *Use* or *Possession* was unrelated to sport performance, then the ingestion, *Use* or *Possession* shall not be considered intentional for purposes of Article 10.2.1 and shall not provide a basis for a finding of *Aggravating Circumstances* under Article 10.4.

### 10.3 *Ineligibility* for Other Anti-Doping Rule Violations

The period of *Ineligibility* for anti-doping rule violations other than as provided in Article 10.2 shall be as follows, unless Article 10.6 or 10.7 are applicable:

- 10.3.1** For violations of Article 2.3 or 2.5, the period of *Ineligibility* shall be four (4) years except: (i) in the case of failing to submit to *Sample* collection, if the *Athlete* can establish that the commission of the anti-doping rule violation was not intentional, the period of *Ineligibility* shall be two (2) years; (ii) in all other cases, if the *Athlete* or other *Person* can establish exceptional circumstances that justify a reduction of the period of *Ineligibility*, the period

<sup>41</sup> [Comment to Article 10.2.3: Article 10.2.3 provides a special definition of “intentional” which is to be applied solely for purposes of Article 10.2.]

<sup>42</sup> [Comment to Article 10.2.4.1: The determinations as to whether the treatment program is approved and whether the *Athlete* or other *Person* has satisfactorily completed the program shall be made in the sole discretion of the UIM. This Article is intended to give the UIM the leeway to apply their own judgment to identify and approve legitimate and reputable, as opposed to “sham”, treatment programs. It is anticipated, however, that the characteristics of legitimate treatment programs may vary widely and change over time such that it would not be practical for WADA to develop mandatory criteria for acceptable treatment programs.]

of *Ineligibility* shall be in a range from two (2) years to four (4) years depending on the *Athlete* or other *Person's* degree of *Fault*; or (iii) in a case involving a *Protected Person* or *Recreational Athlete*, the period of *Ineligibility* shall be in a range between a maximum of two (2) years and, at a minimum, a reprimand and no period of *Ineligibility*, depending on the *Protected Person* or *Recreational Athlete's* degree of *Fault*.

- 10.3.2** For violations of Article 2.4, the period of *Ineligibility* shall be two (2) years, subject to reduction down to a minimum of one (1) year, depending on the *Athlete's* degree of *Fault*. The flexibility between two (2) years and one (1) year of *Ineligibility* in this Article is not available to *Athletes* where a pattern of last-minute whereabouts changes or other conduct raises a serious suspicion that the *Athlete* was trying to avoid being available for *Testing*.
- 10.3.3** For violations of Article 2.7 or 2.8, the period of *Ineligibility* shall be a minimum of four (4) years up to lifetime *Ineligibility*, depending on the seriousness of the violation. An Article 2.7 or Article 2.8 violation involving a *Protected Person* shall be considered a particularly serious violation and, if committed by *Athlete Support Personnel* for violations other than for *Specified Substances*, shall result in lifetime *Ineligibility* for *Athlete Support Personnel*. In addition, significant violations of Article 2.7 or 2.8 which may also violate non-sporting laws and regulations, shall be reported to the competent administrative, professional or judicial authorities.<sup>43</sup>
- 10.3.4** For violations of Article 2.9, the period of *Ineligibility* imposed shall be a minimum of two (2) years, up to lifetime *Ineligibility*, depending on the seriousness of the violation.
- 10.3.5** For violations of Article 2.10, the period of *Ineligibility* shall be two (2) years, subject to reduction down to a minimum of one (1) year, depending on the *Athlete* or other *Person's* degree of *Fault* and other circumstances of the case.<sup>44</sup>
- 10.3.6** For violations of Article 2.11, the period of *Ineligibility* shall be a minimum of two (2) years, up to lifetime *Ineligibility*, depending on the seriousness of the violation by the *Athlete* or other *Person*.<sup>45</sup>

#### **10.4 Aggravating Circumstances which may Increase the Period of *Ineligibility***

If the UIM establishes in an individual case involving an anti-doping rule violation other than violations under Article 2.7 (*Trafficking* or *Attempted Trafficking*), 2.8 (*Administration* or *Attempted Administration*), 2.9 (*Complicity*) or 2.11 (*Acts by an Athlete* or *Other Person* to Discourage or Retaliate Against Reporting) that *Aggravating Circumstances* are present which justify the imposition of a period of *Ineligibility* greater than the standard sanction, then the period of *Ineligibility* otherwise applicable shall be increased by an additional period of *Ineligibility* of up to two (2) years depending on the seriousness of the violation and the nature

<sup>43</sup> [Comment to Article 10.3.3: Those who are involved in doping Athletes or covering up doping should be subject to sanctions which are more severe than the Athletes who test positive. Since the authority of sport organizations is generally limited to *Ineligibility* for accreditation, membership and other sport benefits, reporting Athlete Support Personnel to competent authorities is an important step in the deterrence of doping.]

<sup>44</sup> [Comment to Article 10.3.5: Where the "other Person" referenced in Article 2.10 is an entity and not an individual, that entity may be disciplined as provided in Article 12.]

<sup>45</sup> [Comment to Article 10.3.6: Conduct that is found to violate both Article 2.5 (*Tampering*) and Article 2.11 (*Acts by an Athlete* or *Other Person* to Discourage or Retaliate Against Reporting to Authorities) shall be sanctioned based on the violation that carries the more severe sanction.]

of the *Aggravating Circumstances*, unless the *Athlete* or other *Person* can establish that he or she did not knowingly commit the anti-doping rule violation.<sup>46</sup>

### 10.5 Elimination of the Period of *Ineligibility* where there is *No Fault or Negligence*

If an *Athlete* or other *Person* establishes in an individual case that he or she bears *No Fault or Negligence*, then the otherwise applicable period of *Ineligibility* shall be eliminated.<sup>47</sup>

### 10.6 Reduction of the Period of *Ineligibility* based on *No Significant Fault or Negligence*

#### 10.6.1 Reduction of Sanctions in Particular Circumstances for Violations of Article 2.1, 2.2 or 2.6.

All reductions under Article 10.6.1 are mutually exclusive and not cumulative.

##### 10.6.1.1 *Specified Substances or Specified Methods*

Where the anti-doping rule violation involves a *Specified Substance* (other than a *Substance of Abuse*) or *Specified Method*, and the *Athlete* or other *Person* can establish *No Significant Fault or Negligence*, then the period of *Ineligibility* shall be, at a minimum, a reprimand and no period of *Ineligibility*, and at a maximum, two (2) years of *Ineligibility*, depending on the *Athlete's* or other *Person's* degree of *Fault*.

##### 10.6.1.2 *Contaminated Products*

In cases where the *Athlete* or other *Person* can establish both *No Significant Fault or Negligence* and that the detected *Prohibited Substance* (other than a *Substance of Abuse*) came from a *Contaminated Product*, then the period of *Ineligibility* shall be, at a minimum, a reprimand and no period of *Ineligibility*, and at a maximum, two (2) years *Ineligibility*, depending on the *Athlete* or other *Person's* degree of *Fault*.<sup>48</sup>

<sup>46</sup> [Comment to Article 10.4: Violations under Articles 2.7 (Trafficking or Attempted Trafficking), 2.8 (Administration or Attempted Administration), 2.9 (Complicity or Attempted Complicity) and 2.11 (Acts by an Athlete or Other Person to Discourage or Retaliate Against Reporting to Authorities) are not included in the application of Article 10.4 because the sanctions for these violations already build in sufficient discretion up to a lifetime ban to allow consideration of any Aggravating Circumstance.]

<sup>47</sup> [Comment to Article 10.5: This Article and Article 10.6.2 apply only to the imposition of sanctions; they are not applicable to the determination of whether an anti-doping rule violation has occurred. They will only apply in exceptional circumstances, for example, where an Athlete could prove that, despite all due care, he or she was sabotaged by a competitor. Conversely, *No Fault or Negligence* would not apply in the following circumstances: (a) a positive test resulting from a mislabelled or contaminated vitamin or nutritional supplement (Athletes are responsible for what they ingest (Article 2.1) and have been warned against the possibility of supplement contamination); (b) the Administration of a Prohibited Substance by the Athlete's personal physician or trainer without disclosure to the Athlete (Athletes are responsible for their choice of medical personnel and for advising medical personnel that they cannot be given any Prohibited Substance); and (c) sabotage of the Athlete's food or drink by a spouse, coach or other Person within the Athlete's circle of associates (Athletes are responsible for what they ingest and for the conduct of those Persons to whom they entrust access to their food and drink). However, depending on the unique facts of a particular case, any of the referenced illustrations could result in a reduced sanction under Article 10.6 based on *No Significant Fault or Negligence*.]

<sup>48</sup> [Comment to Article 10.6.1.2: In order to receive the benefit of this Article, the Athlete or other Person must establish not only that the detected Prohibited Substance came from a Contaminated Product, but must also separately establish *No Significant Fault or Negligence*. It should be further noted that Athletes are on notice that they take nutritional supplements at their own risk. The sanction reduction based on *No Significant Fault or Negligence* has rarely been applied in Contaminated Product cases unless the Athlete has exercised a high level of caution before taking the Contaminated Product. In assessing whether the Athlete can establish the source of the Prohibited Substance, it would, for example, be significant for purposes of

### 10.6.1.3 *Protected Persons or Recreational Athletes*

Where the anti-doping rule violation not involving a *Substance of Abuse* is committed by a *Protected Person* or *Recreational Athlete*, and the *Protected Person* or *Recreational Athlete* can establish *No Significant Fault or Negligence*, then the period of *Ineligibility* shall be, at a minimum, a reprimand and no period of *Ineligibility*, and at a maximum, two (2) years *Ineligibility*, depending on the *Protected Person* or *Recreational Athlete's* degree of *Fault*.

### 10.6.2 Application of *No Significant Fault or Negligence* beyond the Application of Article 10.6.1

If an *Athlete* or other *Person* establishes in an individual case where Article 10.6.1 is not applicable that he or she bears *No Significant Fault or Negligence*, then, subject to further reduction or elimination as provided in Article 10.7, the otherwise applicable period of *Ineligibility* may be reduced based on the *Athlete* or other *Person's* degree of *Fault*, but the reduced period of *Ineligibility* may not be less than one-half of the period of *Ineligibility* otherwise applicable. If the otherwise applicable period of *Ineligibility* is a lifetime, the reduced period under this Article may be no less than eight (8) years.<sup>49</sup>

## 10.7 Elimination, Reduction, or Suspension of Period of *Ineligibility* or Other Consequences for Reasons Other than *Fault*

### 10.7.1 *Substantial Assistance* in Discovering or Establishing Code Violations<sup>50</sup>

**10.7.1.1** The UIM may, prior to an appellate decision under Article 13 or the expiration of the time to appeal, suspend a part of the *Consequences* (other than *Disqualification* and mandatory *Public Disclosure*) imposed in an individual case where the *Athlete* or other *Person* has provided *Substantial Assistance* to an *Anti-Doping Organization*, criminal authority or professional disciplinary body which results in: (i) the *Anti-Doping Organization* discovering or bringing forward an anti-doping rule violation by another *Person*; or (ii) which results in a criminal or disciplinary body discovering or bringing forward a criminal offense or the breach of professional rules committed by another *Person* and the information provided by the *Person* providing *Substantial Assistance* is made available to the UIM or other *Anti-Doping Organization* with *Results Management* responsibility; or (iii) which results in WADA initiating a proceeding against a *Signatory*, WADA-accredited laboratory, or *Athlete* passport management unit (as defined in the *International Standard* for Laboratories) for non-compliance with the *Code*, *International Standard* or

---

*establishing whether the Athlete actually Used the Contaminated Product, whether the Athlete had declared the product which was subsequently determined to be contaminated on the Doping Control form.*

This Article should not be extended beyond products that have gone through some process of manufacturing. Where an Adverse Analytical Finding results from environment contamination of a "non-product" such as tap water or lake water in circumstances where no reasonable person would expect any risk of an anti-doping rule violation, typically there would be No Fault or Negligence under Article 10.5.]

<sup>49</sup> [Comment to Article 10.6.2: Article 10.6.2 may be applied to any anti-doping rule violation except those Articles where intent is an element of the anti-doping rule violation (e.g., Article 2.5, 2.7, 2.8, 2.9 or 2.11) or an element of a particular sanction (e.g., Article 10.2.1) or a range of Ineligibility is already provided in an Article based on the Athlete or other Person's degree of Fault.]

<sup>50</sup> [Comment to Article 10.7.1: The cooperation of Athletes, Athlete Support Personnel and other Persons who acknowledge their mistakes and are willing to bring other anti-doping rule violations to light is important to clean sport.]

*Technical Document*; or (iv) with the approval by WADA, which results in a criminal or disciplinary body bringing forward a criminal offense or the breach of professional or sport rules arising out of a sport integrity violation other than doping. After an appellate decision under Article 13 or the expiration of time to appeal, the UIM may only suspend a part of the otherwise applicable *Consequences* with the approval of WADA.

The extent to which the otherwise applicable period of *Ineligibility* may be suspended shall be based on the seriousness of the anti-doping rule violation committed by the *Athlete* or other *Person* and the significance of the *Substantial Assistance* provided by the *Athlete* or other *Person* to the effort to eliminate doping in sport, non-compliance with the *Code* and/or sport integrity violations. No more than three-quarters of the otherwise applicable period of *Ineligibility* may be suspended. If the otherwise applicable period of *Ineligibility* is a lifetime, the non-suspended period under this Article must be no less than eight (8) years. For purposes of this paragraph, the otherwise applicable period of *Ineligibility* shall not include any period of *Ineligibility* that could be added under Article 10.9.3.2 of these Anti-Doping Rules.

If so requested by an *Athlete* or other *Person* who seeks to provide *Substantial Assistance*, the UIM shall allow the *Athlete* or other *Person* to provide the information to it subject to a *Without Prejudice Agreement*.

If the *Athlete* or other *Person* fails to continue to cooperate and to provide the complete and credible *Substantial Assistance* upon which a suspension of *Consequences* was based, the UIM shall reinstate the original *Consequences*. If the UIM decides to reinstate suspended *Consequences* or decides not to reinstate suspended *Consequences*, that decision may be appealed by any *Person* entitled to appeal under Article 13.

- 10.7.1.2** To further encourage *Athletes* and other *Persons* to provide *Substantial Assistance* to *Anti-Doping Organizations*, at the request of the UIM or at the request of the *Athlete* or other *Person* who has, or has been asserted to have, committed an anti-doping rule violation, or other violation of the *Code*, WADA may agree at any stage of the *Results Management* process, including after an appellate decision under Article 13, to what it considers to be an appropriate suspension of the otherwise-applicable period of *Ineligibility* and other *Consequences*. In exceptional circumstances, WADA may agree to suspensions of the period of *Ineligibility* and other *Consequences* for *Substantial Assistance* greater than those otherwise provided in this Article, or even no period of *Ineligibility*, no mandatory *Public Disclosure* and/or no return of prize money or payment of fines or costs. WADA's approval shall be subject to reinstatement of *Consequences*, as otherwise provided in this Article. Notwithstanding Article 13, WADA's decisions in the context of this Article 10.7.1.2 may not be appealed.
- 10.7.1.3** If the UIM suspends any part of an otherwise applicable sanction because of *Substantial Assistance*, then notice providing justification for the decision shall be provided to the other *Anti-Doping Organizations* with a right to appeal under Article 13.2.3 as provided in Article 14.2. In unique circumstances where WADA determines that it would be in the best interest of anti-doping, WADA may authorize the UIM to enter into appropriate

confidentiality agreements limiting or delaying the disclosure of the *Substantial Assistance* agreement or the nature of *Substantial Assistance* being provided.

#### 10.7.2 Admission of an Anti-Doping Rule Violation in the Absence of Other Evidence

Where an *Athlete* or other *Person* voluntarily admits the commission of an anti-doping rule violation before having received notice of a *Sample* collection which could establish an anti-doping rule violation (or, in the case of an anti-doping rule violation other than Article 2.1, before receiving first notice of the admitted violation pursuant to Article 7) and that admission is the only reliable evidence of the violation at the time of admission, then the period of *Ineligibility* may be reduced, but not below one-half of the period of *Ineligibility* otherwise applicable.<sup>51</sup>

#### 10.7.3 Application of Multiple Grounds for Reduction of a Sanction

Where an *Athlete* or other *Person* establishes entitlement to reduction in sanction under more than one provision of Article 10.5, 10.6 or 10.7, before applying any reduction or suspension under Article 10.7, the otherwise applicable period of *Ineligibility* shall be determined in accordance with Articles 10.2, 10.3, 10.5, and 10.6. If the *Athlete* or other *Person* establishes entitlement to a reduction or suspension of the period of *Ineligibility* under Article 10.7, then the period of *Ineligibility* may be reduced or suspended, but not below one-fourth of the otherwise applicable period of *Ineligibility*.

### 10.8 Results Management Agreements

#### 10.8.1 One (1) Year Reduction for Certain Anti-Doping Rule Violations Based on Early Admission and Acceptance of Sanction

Where an *Athlete* or other *Person*, after being notified by the UIM of a potential anti-doping rule violation that carries an asserted period of *Ineligibility* of four (4) or more years (including any period of *Ineligibility* asserted under Article 10.4), admits the violation and accepts the asserted period of *Ineligibility* no later than twenty (20) days after receiving notice of an anti-doping rule violation charge, the *Athlete* or other *Person* may receive a one (1) year reduction in the period of *Ineligibility* asserted by the UIM. Where the *Athlete* or other *Person* receives the one (1) year reduction in the asserted period of *Ineligibility* under this Article 10.8.1, no further reduction in the asserted period of *Ineligibility* shall be allowed under any other Article.<sup>52</sup>

#### 10.8.2 Case Resolution Agreement

Where the *Athlete* or other *Person* admits an anti-doping rule violation after being confronted with the anti-doping rule violation by the UIM and agrees to *Consequences* acceptable to the UIM and WADA, at their sole discretion, then: (a) the *Athlete* or other *Person* may receive a reduction in the period of *Ineligibility* based on an assessment by the UIM and WADA of the application of Articles 10.1 through 10.7 to the asserted anti-doping rule violation, the seriousness of the violation, the *Athlete* or other *Person*'s degree of *Fault* and how promptly the *Athlete* or other *Person* admitted the violation; and (b) the period of *Ineligibility* may start as early as the date of *Sample* collection or the date on which another anti-doping rule violation last occurred. In each case,

<sup>51</sup> [Comment to Article 10.7.2: This Article is intended to apply when an *Athlete* or other *Person* comes forward and admits to an anti-doping rule violation in circumstances where no Anti-Doping Organization is aware that an anti-doping rule violation might have been committed. It is not intended to apply to circumstances where the admission occurs after the *Athlete* or other *Person* believes he or she is about to be caught. The amount by which *Ineligibility* is reduced should be based on the likelihood that the *Athlete* or other *Person* would have been caught had he or she not come forward voluntarily.]

<sup>52</sup> [Comment to Article 10.8.1: For example, if the UIM alleges that an *Athlete* has violated Article 2.1 for Use of an anabolic steroid and asserts the applicable period of *Ineligibility* is four (4) years, then the *Athlete* may unilaterally reduce the period of *Ineligibility* to three (3) years by admitting the violation and accepting the three (3) year period of *Ineligibility* within the time specified in this Article, with no further reduction allowed. This resolves the case without any need for a hearing.]

however, where this Article is applied, the *Athlete* or other *Person* shall serve at least one-half of the agreed-upon period of *Ineligibility* going forward from the earlier of the date the *Athlete* or other *Person* accepted the imposition of a sanction or a *Provisional Suspension* which was subsequently respected by the *Athlete* or other *Person*. The decision by WADA and the UIM to enter or not enter into a case resolution agreement, and the amount of the reduction to, and the starting date of, the period of *Ineligibility* are not matters for determination or review by a hearing body and are not subject to appeal under Article 13.

If so requested by an *Athlete* or other *Person* who seeks to enter into a case resolution agreement under this Article, the UIM shall allow the *Athlete* or other *Person* to discuss an admission of the anti-doping rule violation with it subject to a *Without Prejudice Agreement*.<sup>53</sup>

## 10.9 Multiple Violations

### 10.9.1 Second or Third Anti-Doping Rule Violation

**10.9.1.1** For an *Athlete* or other *Person's* second anti-doping rule violation, the period of *Ineligibility* shall be the greater of:

- (a) A six (6) month period of *Ineligibility*; or
- (b) A period of *Ineligibility* in the range between:
  - (i) the sum of the period of *Ineligibility* imposed for the first anti-doping rule violation plus the period of *Ineligibility* otherwise applicable to the second anti-doping rule violation treated as if it were a first violation, and
  - (ii) twice the period of *Ineligibility* otherwise applicable to the second anti-doping rule violation treated as if it were a first violation. The period of *Ineligibility* shall be determined based on the entirety of the circumstances and the *Athlete* or other *Person's* degree of *Fault* with respect to the second violation.

**10.9.1.2** A third anti-doping rule violation will always result in a lifetime period of *Ineligibility*, except if the third violation fulfils the condition for elimination or reduction of the period of *Ineligibility* under Article 10.5 or 10.6, or involves a violation of Article 2.4. In these particular cases, the period of *Ineligibility* shall be from eight (8) years to lifetime *Ineligibility*.

**10.9.1.3** The period of *Ineligibility* established in Articles 10.9.1.1 and 10.9.1.2 may then be further reduced by the application of Article 10.7.

**10.9.2** An anti-doping rule violation for which an *Athlete* or other *Person* has established *No Fault* or *Negligence* shall not be considered a violation for purposes of this Article 10.9. In addition, an anti-doping rule violation sanctioned under Article 10.2.4.1 shall not be considered a violation for purposes of Article 10.9.

### 10.9.3 Additional Rules for Certain Potential Multiple Violations

**10.9.3.1** For purposes of imposing sanctions under Article 10.9, except as provided in Articles 10.9.3.2 and 10.9.3.3, an anti-doping rule

<sup>53</sup> [Comment to Article 10.8: Any mitigating or aggravating factors set forth in this Article 10 shall be considered in arriving at the Consequences set forth in the case resolution agreement, and shall not be applicable beyond the terms of that agreement.]

violation will only be considered a second violation if the UIM can establish that the *Athlete* or other *Person* committed the additional anti-doping rule violation after the *Athlete* or other *Person* received notice pursuant to Article 7, or after the UIM made reasonable efforts to give notice of the first anti-doping rule violation. If the UIM cannot establish this, the violations shall be considered together as one single first violation, and the sanction imposed shall be based on the violation that carries the more severe sanction, including the application of *Aggravating Circumstances*. Results in all *Competitions* dating back to the earlier anti-doping rule violation will be *Disqualified* as provided in Article 10.10.<sup>54</sup>

- 10.9.3.2** If the UIM establishes that an *Athlete* or other *Person* committed an additional anti-doping rule violation prior to notification, and that the additional violation occurred twelve (12) months or more before or after the first-noticed violation, then the period of *Ineligibility* for the additional violation shall be calculated as if the additional violation were a stand-alone first violation and this period of *Ineligibility* is served consecutively, rather than concurrently, with the period of *Ineligibility* imposed for the earlier-noticed violation. Where this Article 10.9.3.2 applies, the violations taken together shall constitute a single violation for purposes of Article 10.9.1.
- 10.9.3.3** If the UIM establishes that an *Athlete* or other *Person* committed a violation of Article 2.5 in connection with the *Doping Control* process for an underlying asserted anti-doping rule violation, the violation of Article 2.5 shall be treated as a stand-alone first violation and the period of *Ineligibility* for such violation shall be served consecutively, rather than concurrently, with the period of *Ineligibility*, if any, imposed for the underlying anti-doping rule violation. Where this Article 10.9.3.3 is applied, the violations taken together shall constitute a single violation for purposes of Article 10.9.1.
- 10.9.3.4** If the UIM establishes that an *Athlete* or other *Person* has committed a second or third anti-doping rule violation during a period of *Ineligibility*, the periods of *Ineligibility* for the multiple violations shall run consecutively, rather than concurrently.

#### **10.9.4 Multiple Anti-Doping Rule Violations during Ten (10) Year Period**

For purposes of Article 10.9, each anti-doping rule violation must take place within the same ten (10) year period in order to be considered multiple violations.

### **10.10 Disqualification of Results in Competitions Subsequent to Sample Collection or Commission of an Anti-Doping Rule Violation**

In addition to the automatic *Disqualification* of the results in the *Competition* which produced the positive *Sample* under Article 9, all other competitive results of the *Athlete* obtained from the date a positive *Sample* was collected (whether *In-Competition* or *Out-of-Competition*), or other anti-doping rule violation occurred, through the commencement of any *Provisional*

<sup>54</sup> [Comment to Article 10.9.3.1: The same rule applies where, after the imposition of a sanction, the UIM discovers facts involving an anti-doping rule violation that occurred prior to notification for a first anti-doping rule violation – e.g., the UIM shall impose a sanction based on the sanction that could have been imposed if the two (2) violations had been adjudicated at the same time, including the application of *Aggravating Circumstances*.]

*Suspension or Ineligibility* period, shall, unless fairness requires otherwise, be *Disqualified* with all of the resulting *Consequences* including forfeiture of any medals, points and prizes.<sup>55</sup>

### 10.11 Forfeited Prize Money

If the UIM recovers prize money forfeited as a result of an anti-doping rule violation, it shall take reasonable measures to allocate and distribute this prize money to the *Athletes* who would have been entitled to it had the forfeiting *Athlete* not competed.<sup>56</sup>

### 10.12 Financial Consequences

**10.12.1** Where an *Athlete* or other *Person* commits an anti-doping rule violation, the UIM may, in its discretion and subject to the principle of proportionality, elect to (a) recover from the *Athlete* or other *Person* costs associated with the anti-doping rule violation, regardless of the period of *Ineligibility* imposed and/or (b) fine the *Athlete* or other *Person* in an amount up to 5'000 Euros, only in cases where the maximum period of *Ineligibility* otherwise applicable has already been imposed.

**10.12.2** The imposition of a financial sanction or the UIM's recovery of costs shall not be considered a basis for reducing the *Ineligibility* or other sanction which would otherwise be applicable under these Anti-Doping Rules.

### 10.13 Commencement of *Ineligibility* Period

Where an *Athlete* is already serving a period of *Ineligibility* for an anti-doping rule violation, any new period of *Ineligibility* shall commence on the first day after the current period of *Ineligibility* has been served. Otherwise, except as provided below, the period of *Ineligibility* shall start on the date of the final hearing decision providing for *Ineligibility* or, if the hearing is waived or there is no hearing, on the date *Ineligibility* is accepted or otherwise imposed.

#### 10.13.1 Delays Not Attributable to the *Athlete* or other *Person*

Where there have been substantial delays in the hearing process or other aspects of *Doping Control*, and the *Athlete* or other *Person* can establish that such delays are not attributable to the *Athlete* or other *Person*, the UIM or the UIM Anti-Doping Hearing Panel, if applicable, may start the period of *Ineligibility* at an earlier date commencing as early as the date of *Sample* collection or the date on which another anti-doping rule violation last occurred. All competitive results achieved during the period of *Ineligibility*, including retroactive *Ineligibility*, shall be *Disqualified*.<sup>57</sup>

#### 10.13.2 Credit for *Provisional Suspension* or Period of *Ineligibility* Served

**10.13.2.1** If a *Provisional Suspension* is respected by the *Athlete* or other *Person*, then the *Athlete* or other *Person* shall receive a credit for such period of *Provisional Suspension* against any period of *Ineligibility* which may ultimately be imposed. If the *Athlete* or

<sup>55</sup> [Comment to Article 10.10: Nothing in these Anti-Doping Rules precludes clean *Athletes* or other *Persons* who have been damaged by the actions of a *Person* who has committed an anti-doping rule violation from pursuing any right which they would otherwise have to seek damages from such *Person*.]

<sup>56</sup> [Comment to Article 10.11: This Article is not intended to impose an affirmative duty on the UIM to take any action to collect forfeited prize money. If the UIM elects not to take any action to collect forfeited prize money, it may assign its right to recover such money to the *Athlete(s)* who should have otherwise received the money. "Reasonable measures to allocate and distribute this prize money" could include using collected forfeited prize money as agreed upon by the UIM and its *Athletes*.]

<sup>57</sup> [Comment to Article 10.13.1: In cases of anti-doping rule violations other than under Article 2.1, the time required for an Anti-Doping Organization to discover and develop facts sufficient to establish an anti-doping rule violation may be lengthy, particularly where the *Athlete* or other *Person* has taken affirmative action to avoid detection. In these circumstances, the flexibility provided in this Article to start the sanction at an earlier date should not be used.]

other *Person* does not respect a *Provisional Suspension*, then the *Athlete* or other *Person* shall receive no credit for any period of *Provisional Suspension* served. If a period of *Ineligibility* is served pursuant to a decision that is subsequently appealed, then the *Athlete* or other *Person* shall receive a credit for such period of *Ineligibility* served against any period of *Ineligibility* which may ultimately be imposed on appeal.

- 10.13.2.2** If an *Athlete* or other *Person* voluntarily accepts a *Provisional Suspension* in writing from the UIM and thereafter respects the *Provisional Suspension*, the *Athlete* or other *Person* shall receive a credit for such period of voluntary *Provisional Suspension* against any period of *Ineligibility* which may ultimately be imposed. A copy of the *Athlete* or other *Person*'s voluntary acceptance of a *Provisional Suspension* shall be provided promptly to each party entitled to receive notice of an asserted anti-doping rule violation under Article 14.1.<sup>58</sup>
- 10.13.2.3** No credit against a period of *Ineligibility* shall be given for any time period before the effective date of the *Provisional Suspension* or voluntary *Provisional Suspension* regardless of whether the *Athlete* elected not to compete or was suspended by a team.
- 10.13.2.4** In *Team Sports*, where a period of *Ineligibility* is imposed upon a team, unless fairness requires otherwise, the period of *Ineligibility* shall start on the date of the final hearing decision providing for *Ineligibility* or, if the hearing is waived, on the date *Ineligibility* is accepted or otherwise imposed. Any period of team *Provisional Suspension* (whether imposed or voluntarily accepted) shall be credited against the total period of *Ineligibility* to be served.]

## 10.14 Status During Ineligibility or Provisional Suspension

### 10.14.1 Prohibition Against Participation During *Ineligibility* or *Provisional Suspension*

No *Athlete* or other *Person* who has been declared *Ineligible* or is subject to a *Provisional Suspension* may, during a period of *Ineligibility* or *Provisional Suspension*, participate in any capacity in a *Competition* or activity (other than authorized anti-doping *Education* or rehabilitation programs) authorized or organized by any *Signatory*, *Signatory's* member organization, or a club or other member organization of a *Signatory's* member organization, or in *Competitions* authorized or organized by any professional league or any international- or national-level *Event* organization or any elite or national-level sporting activity funded by a governmental agency.

An *Athlete* or other *Person* subject to a period of *Ineligibility* longer than four (4) years may, after completing four (4) years of the period of *Ineligibility*, participate as an *Athlete* in local sport events not sanctioned or otherwise under the authority of a *Code Signatory* or member of a *Code Signatory*, but only so long as the local sport event is not at a level that could otherwise qualify such *Athlete* or other *Person* directly or indirectly to compete in (or accumulate points toward) a national championship or *International Event*, and does not involve the *Athlete* or other *Person* working in any capacity with *Protected Persons*.

<sup>58</sup> [Comment to Article 10.13.2.2: An *Athlete's* voluntary acceptance of a *Provisional Suspension* is not an admission by the *Athlete* and shall not be used in any way to draw an adverse inference against the *Athlete*.]

An *Athlete* or other *Person* subject to a period of *Ineligibility* shall remain subject to *Testing* and any requirement by the UIM to provide whereabouts information.<sup>59</sup>

#### 10.14.2 Return to Training

As an exception to Article 10.14.1, an *Athlete* may return to train with a team or to use the facilities of a club or other member organization of the UIM's or other *Signatory's* member organization during the shorter of: (1) the last two months of the *Athlete's* period of *Ineligibility*, or (2) the last one-quarter of the period of *Ineligibility* imposed.<sup>60</sup>

#### 10.14.3 Violation of the Prohibition of Participation During *Ineligibility* or *Provisional Suspension*

Where an *Athlete* or other *Person* who has been declared *Ineligible* violates the prohibition against participation during *Ineligibility* described in Article 10.14.1, the results of such participation shall be *Disqualified* and a new period of *Ineligibility* equal in length to the original period of *Ineligibility* shall be added to the end of the original period of *Ineligibility*. The new period of *Ineligibility*, including a reprimand and no period of *Ineligibility*, may be adjusted based on the *Athlete* or other *Person's* degree of *Fault* and other circumstances of the case. The determination of whether an *Athlete* or other *Person* has violated the prohibition against participation, and whether an adjustment is appropriate, shall be made by the *Anti-Doping Organization* whose *Results Management* led to the imposition of the initial period of *Ineligibility*. This decision may be appealed under Article 13.

An *Athlete* or other *Person* who violates the prohibition against participation during a *Provisional Suspension* described in Article 10.14.1 shall receive no credit for any period of *Provisional Suspension* served and the results of such participation shall be *Disqualified*.

Where an *Athlete Support Person* or other *Person* assists a *Person* in violating the prohibition against participation during *Ineligibility* or a *Provisional Suspension*, the UIM shall impose sanctions for a violation of Article 2.9 for such assistance.

#### 10.14.4 Withholding of Financial Support during *Ineligibility*

In addition, for any anti-doping rule violation not involving a reduced sanction as described in Article 10.5 or 10.6, some or all sport-related financial support or other sport-related benefits received by such *Person* will be withheld by the UIM and its *National Authorities*.

### 10.15 Automatic Publication of Sanction

A mandatory part of each sanction shall include automatic publication, as provided in Article 14.3.

<sup>59</sup> [Comment to Article 10.14.1: For example, subject to Article 10.14.2 below, *Ineligible Athletes* cannot participate in a training camp, exhibition or practice organized by their *National Authority* or a club which is a member of that *National Authority* or which is funded by a governmental agency. Further, an *Ineligible Athlete* may not compete in a non-*Signatory* professional league (e.g., the *National Hockey League*, the *National Basketball Association*, etc.), Events organized by a non-*Signatory* International Event organization or a non-*Signatory* national-level Event organization without triggering the Consequences set forth in Article 10.14.3. The term "activity" also includes, for example, administrative activities, such as serving as an official, director, officer, employee, or volunteer of the organization described in this Article. *Ineligibility* imposed in one sport shall also be recognized by other sports (see Article 15.1, *Automatic Binding Effect of Decisions*). An *Athlete* or other *Person* serving a period of *Ineligibility* is prohibited from coaching or serving as an *Athlete Support Person* in any other capacity at any time during the period of *Ineligibility*, and doing so could also result in a violation of Article 2.10 by another *Athlete*. Any performance standard accomplished during a period of *Ineligibility* shall not be recognized by the UIM or its *National Authorities* for any purpose.]

<sup>60</sup> [Comment to Article 10.14.2: In many Team Sports and some individual sports (e.g., ski jumping and gymnastics), *Athletes* cannot effectively train on their own so as to be ready to compete at the end of the *Athlete's* period of *Ineligibility*. During the training period described in this Article, an *Ineligible Athlete* may not compete or engage in any activity described in Article 10.14.1 other than training.]

## ARTICLE 11 CONSEQUENCES TO TEAMS

### 11.1 Testing of Teams

Where one (1) member of a team (outside of *Team Sports*) has been notified of an anti-doping rule violation under Article 7 in connection with an *Event*, the ruling body for the *Event* shall conduct appropriate *Target Testing* of all members of the team during the *Event Period*.

### 11.2 Consequences for Teams

- 11.2.1** An anti-doping rule violation committed by a member of a team in connection with an *In-Competition* test automatically leads to *Disqualification* of the result obtained by the team in that *Competition*, with all resulting *Consequences* for the team and its members, including forfeiture of any medals, points and prizes.
- 11.2.2** An anti-doping rule violation committed by a member of a team occurring during or in connection with an *Event* may lead to *Disqualification* of all of the results obtained by the team in that *Event* with all *Consequences* for the team and its members, including forfeiture of all medals, points and prizes, except as provided in Article 11.2.3.
- 11.2.3** Where an *Athlete* who is a member of a team committed an anti-doping rule violation during or in connection with one (1) *Competition* in an *Event*, if the other member(s) of the team establish(es) that he or she/they bear(s) *No Fault* or *Negligence* for that violation, the results of the team in any other *Competition(s)* in that *Event* shall not be *Disqualified* unless the results of the team in the *Competition(s)* other than the *Competition* in which the anti-doping rule violation occurred were likely to have been affected by the *Athlete's* anti-doping rule violation.

## ARTICLE 12 SANCTIONS BY the UIM AGAINST OTHER SPORTING BODIES

When the UIM becomes aware that a *National Authority* or any other sporting body over which it has authority has failed to comply with, implement, uphold, and enforce these Anti-Doping Rules within that organization's or body's area of competence, the UIM has the authority and may take the following additional disciplinary actions:

**12.1 Exclude all, or some group of, members of that organization or body from specified future *Events* or all *Events* conducted within a specified period of time.**

**12.2 Take additional disciplinary actions with respect to that organization's or body's recognition, the eligibility of their members to participate in the UIM's activities, and/or fine that organization or body based on the following:**

- 12.2.1** Four (4) or more violations of these Anti-Doping Rules (other than violations involving Article 2.4) are committed by *Athletes* or other *Persons* affiliated with that organization or body during a twelve (12) month period. In such event: (a) all or some group of members of that organization or body may be banned from participation in any the UIM activities for a period of up to two (2) years and/or (b) that organization or body may be fined in an amount up to 5'000 Euros.
- 12.2.2** Four (4) or more violations of these Anti-Doping Rules (other than violations involving Article 2.4) are committed in addition to the violations described in Article 12.2.1 by *Athletes* or other *Persons* affiliated with that organization or body during a twelve (12) month period. In such event, that organization or body may be suspended for a period of up to four (4) years.

**12.2.3** More than one *Athlete* or other *Person* affiliated with that organization or body commits an anti-doping rule violation during an *International Event*. In such event, that organization or body may be fined in an amount up to 5'000 Euros.

**12.2.4** That organization or body has failed to make diligent efforts to keep the UIM informed about an *Athlete's* whereabouts after receiving a request for that information from the UIM. In such event, that organization or body may be fined in an amount up to 1'000 Euros per *Athlete*, in addition to reimbursement of all of the UIM costs incurred in *Testing* that organization's or body's *Athletes*.

**12.3 Withhold some or all funding or other financial and non-financial support to that organization or body.**

**12.4 Oblige that organization or body to reimburse the UIM for all costs (including but not limited to laboratory fees, hearing expenses and travel) related to a violation of these Anti-Doping Rules committed by an *Athlete* or other *Person* affiliated with that organization or body.**

## **ARTICLE 13 RESULTS MANAGEMENT: APPEALS <sup>61</sup>**

### **13.1 Decisions Subject to Appeal**

Decisions made under the *Code* or these Anti-Doping Rules may be appealed as set forth below in Articles 13.2 through 13.7 or as otherwise provided in these Anti-Doping Rules, the *Code* or the *International Standards*. Such decisions shall remain in effect while under appeal unless the appellate body orders otherwise.

#### **13.1.1 Scope of Review Not Limited**

The scope of review on appeal includes all issues relevant to the matter and is expressly not limited to the issues or scope of review before the initial decision maker. Any party to the appeal may submit evidence, legal arguments and claims that were not raised in the first instance hearing so long as they arise from the same cause of action or same general facts or circumstances raised or addressed in the first instance hearing.<sup>62</sup>

#### **13.1.2 CAS Shall Not Defer to the Findings Being Appealed**

In making its decision, CAS shall not give deference to the discretion exercised by the body whose decision is being appealed.<sup>63</sup>

#### **13.1.3 WADA Not Required to Exhaust Internal Remedies**

<sup>61</sup> [Comment to Article 13: The object of the Code is to have anti-doping matters resolved through fair and transparent internal processes with a final appeal. Anti-doping decisions by Anti-Doping Organizations are made transparent in Article 14. Specified Persons and organizations, including WADA, are then given the opportunity to appeal those decisions. Note that the definition of interested Persons and organizations with a right to appeal under Article 13 does not include Athletes, or their federations, who might benefit from having another competitor Disqualified.]

<sup>62</sup> [Comment to Article 13.1.1: The revised language is not intended to make a substantive change to the 2015 Code, but rather for clarification. For example, where an Athlete was charged in the first instance hearing only with Tampering but the same conduct could also constitute Complicity, an appealing party could pursue both Tampering and Complicity charges against the Athlete in the appeal.]

<sup>63</sup> [Comment to Article 13.1.2: CAS proceedings are de novo. Prior proceedings do not limit the evidence or carry weight in the hearing before CAS.]

Where *WADA* has a right to appeal under Article 13 and no other party has appealed a final decision within the *UIM*'s process, *WADA* may appeal such decision directly to *CAS* without having to exhaust other remedies in the *UIM*'s process.<sup>64</sup>

### **13.2 Appeals from Decisions Regarding Anti-Doping Rule Violations, *Consequences*, *Provisional Suspensions*, Implementation of Decisions and Authority**

A decision that an anti-doping rule violation was committed, a decision imposing *Consequences* or not imposing *Consequences* for an anti-doping rule violation, or a decision that no anti-doping rule violation was committed; a decision that an anti-doping rule violation proceeding cannot go forward for procedural reasons (including, for example, prescription); a decision by *WADA* not to grant an exception to the six (6) months notice requirement for a retired *Athlete* to return to competition under Article 5.6.1; a decision by *WADA* assigning *Results Management* under Article 7.1 of the *Code*; a decision by the *UIM* not to bring forward an *Adverse Analytical Finding* or an *Atypical Finding* as an anti-doping rule violation, or a decision not to go forward with an anti-doping rule violation after an investigation in accordance with the *International Standard for Results Management*; a decision to impose, or lift, a *Provisional Suspension* as a result of a *Provisional Hearing*; the *UIM*'s failure to comply with Article 7.4; a decision that the *UIM* lacks authority to rule on an alleged anti-doping rule violation or its *Consequences*; a decision to suspend, or not suspend, *Consequences* or to reinstate, or not reinstate, *Consequences* under Article 10.7.1; failure to comply with Articles 7.1.4 and 7.1.5 of the *Code*; failure to comply with Article 10.8.1; a decision under Article 10.14.3; a decision by the *UIM* not to implement another *Anti-Doping Organization*'s decision under Article 15; and a decision under Article 27.3 of the *Code* may be appealed exclusively as provided in this Article 13.2.

#### **13.2.1 Appeals Involving *International-Level Athletes* or *International Events***

In cases arising from participation in an *International Event* or in cases involving *International-Level Athletes*, the decision may be appealed exclusively to *CAS*.<sup>65</sup>

#### **13.2.2 Appeals Involving Other *Athletes* or Other *Persons***

In cases where Article 13.2.1 is not applicable, the decision may be appealed to an appellate body, in accordance with rules adopted by the *National Anti-Doping Organization* having authority over the *Athlete* or other *Person*.

The rules for such appeal shall respect the following principles: a timely hearing; a fair, impartial, *Operationally Independent* and *Institutionally Independent* hearing panel; the right to be represented by counsel at the *Person*'s own expense; and a timely, written, reasoned decision.

If no such body as described above is in place and available at the time of the appeal, the decision may be appealed to *CAS* in accordance with the applicable procedural rules.

#### **13.2.3 *Persons* Entitled to Appeal**

##### **13.2.3.1 Appeals Involving *International-Level Athletes* or *International Events***

In cases under Article 13.2.1, the following parties shall have the right to appeal to *CAS*: (a) the *Athlete* or other *Person* who is the subject of the

<sup>64</sup> [Comment to Article 13.1.3: Where a decision has been rendered before the final stage of the *UIM*'s process (for example, a first hearing) and no party elects to appeal that decision to the next level of the *UIM*'s process (e.g., the *Managing Board*), then *WADA* may bypass the remaining steps in the *UIM*'s internal process and appeal directly to *CAS*.]

<sup>65</sup> [Comment to Article 13.2.1: *CAS* decisions are final and binding except for any review required by law applicable to the annulment or enforcement of arbitral awards.]

decision being appealed; (b) the other party to the case in which the decision was rendered; (c) the UIM; (d) the *National Anti-Doping Organization* of the *Person's* country of residence or countries where the *Person* is a national or license holder; (e) the International Olympic Committee or International Paralympic Committee, as applicable, where the decision may have an effect in relation to the Olympic Games or Paralympic Games, including decisions affecting eligibility for the Olympic Games or Paralympic Games; and (f) *WADA*.

#### **13.2.3.2 Appeals Involving Other *Athletes* or Other *Persons***

In cases under Article 13.2.2, the parties having the right to appeal to the national-level appeal body shall be as provided in the *National Anti-Doping Organization's* rules but, at a minimum, shall include the following parties: (a) the *Athlete* or other *Person* who is the subject of the decision being appealed; (b) the other party to the case in which the decision was rendered; (c) the UIM; (d) the *National Anti-Doping Organization* of the *Person's* country of residence or countries where the *Person* is a national or license holder; (e) the International Olympic Committee or International Paralympic Committee, as applicable, where the decision may have an effect in relation to the Olympic Games or Paralympic Games, including decisions affecting eligibility for the Olympic Games or Paralympic Games; and (f) *WADA*.

For cases under Article 13.2.2, *WADA*, the International Olympic Committee, the International Paralympic Committee, and the UIM shall also have the right to appeal to *CAS* with respect to the decision of the national-level appeal body.

Any party filing an appeal shall be entitled to assistance from *CAS* to obtain all relevant information from the *Anti-Doping Organization* whose decision is being appealed and the information shall be provided if *CAS* so directs.

#### **13.2.3.3 Duty to Notify**

All parties to any *CAS* appeal must ensure that *WADA* and all other parties with a right to appeal have been given timely notice of the appeal.

#### **13.2.3.4 Appeal from Imposition of *Provisional Suspension***

Notwithstanding any other provision herein, the only *Person* who may appeal from the imposition of a *Provisional Suspension* is the *Athlete* or other *Person* upon whom the *Provisional Suspension* is imposed.

#### **13.2.3.5 Appeal from Decisions under Article 12**

Decisions by the UIM pursuant to Article 12 may be appealed exclusively to *CAS* by the *National Authority* or other body.

### **13.2.4 Cross Appeals and other Subsequent Appeals Allowed**

Cross appeals and other subsequent appeals by any respondent named in cases brought to *CAS* under the *Code* are specifically permitted. Any party with a right to appeal under this Article 13 must file a cross appeal or subsequent appeal at the latest with the party's answer.<sup>66</sup>

<sup>66</sup> [Comment to Article 13.2.4: This provision is necessary because since 2011, *CAS* rules no longer permit an *Athlete* the right to cross appeal when an *Anti-Doping Organization* appeals a decision after the *Athlete's* time for appeal has expired. This provision permits a full hearing for all parties.]

### 13.3 Failure to Render a Timely Decision by the UIM

Where, in a particular case, the UIM fails to render a decision with respect to whether an anti-doping rule violation was committed within a reasonable deadline set by WADA, WADA may elect to appeal directly to CAS as if the UIM had rendered a decision finding no anti-doping rule violation. If the CAS hearing panel determines that an anti-doping rule violation was committed and that WADA acted reasonably in electing to appeal directly to CAS, then WADA's costs and attorney fees in prosecuting the appeal shall be reimbursed to WADA by the UIM.<sup>67</sup>

### 13.4 Appeals Relating to TUEs

TUE decisions may be appealed exclusively as provided in Article 4.4.

### 13.5 Notification of Appeal Decisions

The UIM shall promptly provide the appeal decision to the *Athlete* or other *Person* and to the other *Anti-Doping Organizations* that would have been entitled to appeal under Article 13.2.3 as provided under Article 14.2.

### 13.6 Time for Filing Appeals<sup>68</sup>

#### 13.6.1 Appeals to CAS

The time to file an appeal to CAS shall be twenty-one (21) days from the date of receipt of the decision by the appealing party. The above notwithstanding, the following shall apply in connection with appeals filed by a party entitled to appeal but which was not a party to the proceedings that led to the decision being appealed:

- (a) Within fifteen (15) days from the notice of the decision, such party/ies shall have the right to request a copy of the full case file pertaining to the decision from the *Anti-Doping Organization* that had *Results Management* authority;
- (b) If such a request is made within the fifteen (15) day period, then the party making such request shall have twenty-one (21) days from receipt of the file to file an appeal to CAS.

The above notwithstanding, the filing deadline for an appeal filed by WADA shall be the later of:

- (a) Twenty-one (21) days after the last day on which any other party having a right to appeal could have appealed, or
- (b) Twenty-one (21) days after WADA's receipt of the complete file relating to the decision.

#### 13.6.2 Appeals Under Article 13.2.2

The time to file an appeal to an independent and impartial body in accordance with rules established by the *National Anti-Doping Organization* shall be indicated by the same rules of the *National Anti-Doping Organization*.

<sup>67</sup> [Comment to Article 13.3: Given the different circumstances of each anti-doping rule violation investigation and Results Management process, it is not feasible to establish a fixed time period for the UIM to render a decision before WADA may intervene by appealing directly to CAS. Before taking such action, however, WADA will consult with the UIM and give the UIM an opportunity to explain why it has not yet rendered a decision.]

<sup>68</sup> [Comment to Article 13.6: Whether governed by CAS rules or these Anti-Doping Rules, a party's deadline to appeal does not begin running until receipt of the decision. For that reason, there can be no expiration of a party's right to appeal if the party has not received the decision.]

The above notwithstanding, the filing deadline for an appeal filed by WADA shall be the later of:

- (a) Twenty-one (21) days after the last day on which any other party having a right to appeal could have appealed, or
- (b) Twenty-one (21) days after WADA's receipt of the complete file relating to the decision.

## ARTICLE 14 CONFIDENTIALITY AND REPORTING

### 14.1 Information Concerning *Adverse Analytical Findings, Atypical Findings, and Other Asserted Anti-Doping Rule Violations*

#### 14.1.1 Notice of Anti-Doping Rule Violations to *Athletes* and other *Persons*

Notice to *Athletes* or other *Persons* of anti-doping rule violations asserted against them shall occur as provided under Articles 7 and 14.

If at any point during *Results Management* up until the anti-doping rule violation charge, the UIM decides not to move forward with a matter, it must notify the *Athlete* or other *Person*, (provided that the *Athlete* or other *Person* had been already informed of the ongoing *Results Management*).

Notice shall be delivered or emailed to *Athletes* or other *Persons*. If the notification takes place via the *Athlete* or other *Person's National Authority*, the *National Authority* shall confirm to the UIM that they have received the notification and that the notification has been provided to the *Athlete* or other *Person*.

#### 14.1.2 Notice of Anti-Doping Rule Violations to *National Anti-Doping Organizations* and WADA

Notice of the assertion of an anti-doping rule violation to the *Athlete's* or other *Person's National Anti-Doping Organization* and WADA shall occur as provided under Articles 7 and 14, simultaneously with the notice to the *Athlete* or other *Person*.

If at any point during *Results Management* up until the anti-doping rule violation charge, the UIM decides not to move forward with a matter, it must give notice (with reasons) to the *Anti-Doping Organizations* with a right of appeal under Article 13.2.3.

Notice shall be delivered or emailed.

#### 14.1.3 Content of an Anti-Doping Rule Violation Notice

Notification of an anti-doping rule violation shall include: the *Athlete's* or other *Person's* name, country, sport and discipline within the sport, the *Athlete's* competitive level, whether the test was *In-Competition* or *Out-of-Competition*, the date of *Sample* collection, the analytical result reported by the laboratory, and other information as required by the *International Standard for Testing and Investigations* and *International Standard for Results Management*.

Notification of anti-doping rule violations other than under Article 2.1 shall also include the rule violated and the basis of the asserted violation.

#### 14.1.4 Status Reports

Except with respect to investigations which have not resulted in a notice of an anti-doping rule violation pursuant to Article 14.1.1, the *Athlete's* or other *Person's National Anti-Doping Organization* and WADA shall be regularly updated on the status and findings of any review or proceedings conducted pursuant to Article 7, 8 or 13 and shall

be provided with a prompt written reasoned explanation or decision explaining the resolution of the matter.

#### **14.1.5 Confidentiality**

The recipient organizations shall not disclose this information beyond those *Persons* with a need to know (which would include the appropriate personnel at the applicable *National Olympic Committee, National Authority*, until the UIM has made *Public Disclosure* as in mitted by Article 14.3.

#### **14.1.6 Protection of Confidential Information by an Employee or Agent of the UIM**

The UIM shall ensure that information concerning *Adverse Analytical Findings, Atypical Findings*, and other asserted anti-doping rule violations remains confidential until such information is *Publicly Disclosed* in accordance with Article 14.3. the UIM shall ensure that its employees (whether permanent or otherwise), contractors, agents, consultants, and *Delegated Third Parties* are subject to fully enforceable contractual duty of confidentiality and to fully enforceable procedures for the investigation and disciplining of improper and/or unauthorized disclosure of such confidential information.

### **14.2 Notice of Anti-Doping Rule Violation or Violations of *Ineligibility* or *Provisional Suspension* Decisions and Request for Files**

**14.2.1** Anti-doping rule violation decisions or decisions related to violations of *Ineligibility* or *Provisional Suspension* rendered pursuant to Article 7.6, 8.2, 10.5, 10.6, 10.7, 10.14.3 or 13.5 shall include the full reasons for the decision, including, if applicable, a justification for why the maximum potential sanction was not imposed. Where the decision is not in English or French, the UIM shall provide an English or French summary of the decision and the supporting reasons.

**14.2.2** An *Anti-Doping Organization* having a right to appeal a decision received pursuant to Article 14.2.1 may, within fifteen (15) days of receipt, request a copy of the full case file pertaining to the decision.

### **14.3 Public Disclosure**

**14.3.1** After notice has been provided to the *Athlete* or other *Person* in accordance with the *International Standard for Results Management*, and to the applicable *Anti-Doping Organizations* in accordance with Article 14.1.2, the identity of any *Athlete* or other *Person* who is notified of a potential anti-doping rule violation, the *Prohibited Substance* or *Prohibited Method* and the nature of the violation involved, and whether the *Athlete* or other *Person* is subject to a *Provisional Suspension* may be *Publicly Disclosed* by the UIM.

**14.3.2** No later than twenty (20) days after it has been determined in an appellate decision under Article 13.2.1 or 13.2.2, or such appeal has been waived, or a hearing in accordance with Article 8 has been waived, or the assertion of an anti-doping rule violation has not otherwise been timely challenged, or the matter has been resolved under Article 10.8, or a new period of *Ineligibility*, or reprimand, has been imposed under Article 10.14.3, the UIM must *Publicly Disclose* the disposition of the anti-doping matter, including the sport, the anti-doping rule violated, the name of the *Athlete* or other *Person* committing the violation, the *Prohibited Substance* or *Prohibited Method* involved (if any) and the *Consequences* imposed. The UIM must also *Publicly Disclose* within

twenty (20) days the results of appellate decisions concerning anti-doping rule violations, including the information described above.<sup>69</sup>

- 14.3.3** After an anti-doping rule violation has been determined to have been committed in an appellate decision under Article 13.2.1 or 13.2.2 or such appeal has been waived, or in a hearing in accordance with Article 8 or where such hearing has been waived, or the assertion of an anti-doping rule violation has not otherwise been timely challenged, or the matter has been resolved under Article 10.8, the UIM may make public such determination or decision and may comment publicly on the matter.
- 14.3.4** In any case where it is determined, after a hearing or appeal, that the *Athlete* or other *Person* did not commit an anti-doping rule violation, the fact that the decision has been appealed may be *Publicly Disclosed*. However, the decision itself and the underlying facts may not be *Publicly Disclosed* except with the consent of the *Athlete* or other *Person* who is the subject of the decision. The UIM shall use reasonable efforts to obtain such consent, and if consent is obtained, shall *Publicly Disclose* the decision in its entirety or in such redacted form as the *Athlete* or other *Person* may approve.
- 14.3.5** Publication shall be accomplished at a minimum by placing the required information on the UIM's website and leaving the information up for the longer of one (1) month or the duration of any period of *Ineligibility*. It will be removed immediately after the expiry of the indicated time periods.
- 14.3.6** Except as provided in Articles 14.3.1 and 14.3.3, no *Anti-Doping Organization*, *National Authority*, or *WADA*-accredited laboratory, or any official of any such body, shall publicly comment on the specific facts of any pending case (as opposed to general description of process and science) except in response to public comments attributed to, or based on information provided by, the *Athlete*, other *Person* or their entourage or other representatives.
- 14.3.7** The mandatory *Public Disclosure* required in Article 14.3.2 shall not be required where the *Athlete* or other *Person* who has been found to have committed an anti-doping rule violation is a *Minor*, *Protected Person* or *Recreational Athlete*. Any optional *Public Disclosure* in a case involving a *Minor*, *Protected Person* or *Recreational Athlete* shall be proportionate to the facts and circumstances of the case.

#### 14.4 Statistical Reporting

The UIM shall, at least annually, publish publicly a general statistical report of its *Doping Control* activities, with a copy provided to *WADA*. The UIM may also publish reports showing the name of each *Athlete* tested and the date of each *Testing*.

#### 14.5 Doping Control Information Database and Monitoring of Compliance

To enable *WADA* to perform its compliance monitoring role and to ensure the effective use of resources and sharing of applicable *Doping Control* information among *Anti-Doping Organizations*, the UIM shall report to *WADA* through *ADAMS Doping Control*-related information, including, in particular:

- (a) *Athlete Biological Passport* data for *International-Level Athletes* and *National-Level Athletes*,
- (b) Whereabouts information for *Athletes* including those in *Registered Testing Pools*,

<sup>69</sup> [Comment to Article 14.3.2: Where *Public Disclosure* as required by Article 14.3.2 would result in a breach of other applicable laws, the UIM's failure to make the *Public Disclosure* will not result in a determination of non-compliance with Code as set forth in Article 4.1 of the *International Standard for the Protection of Privacy and Personal Information*.]

- (c) *TUE* decisions, and
- (d) *Results Management* decisions,

as required under the applicable *International Standard(s)*.

- 14.5.1** To facilitate coordinated test distribution planning, avoid unnecessary duplication in *Testing* by various *Anti-Doping Organizations*, and to ensure that *Athlete Biological Passport* profiles are updated, the UIM shall report all *In-Competition* and *Out-of-Competition* tests to WADA by entering the *Doping Control* forms into ADAMS in accordance with the requirements and timelines contained in the *International Standard* for *Testing* and *Investigations*.
- 14.5.2** To facilitate WADA's oversight and appeal rights for *TUEs*, the UIM shall report all *TUE* applications, decisions and supporting documentation using ADAMS in accordance with the requirements and timelines contained in the *International Standard* for *Therapeutic Use Exemptions*.
- 14.5.3** To facilitate WADA's oversight and appeal rights for *Results Management*, the UIM shall report the following information into ADAMS in accordance with the requirements and timelines outlined in the *International Standard* for *Results Management*: (a) notifications of anti-doping rule violations and related decisions for *Adverse Analytical Findings*; (b) notifications and related decisions for other anti-doping rule violations that are not *Adverse Analytical Findings*; (c) whereabouts failures; and (d) any decision imposing, lifting or reinstating a *Provisional Suspension*.
- 14.5.4** The information described in this Article will be made accessible, where appropriate and in accordance with the applicable rules, to the *Athlete*, the *Athlete's National Anti-Doping Organization*, and any other *Anti-Doping Organizations* with *Testing* authority over the *Athlete*.

## 14.6 Data Privacy

- 14.6.1** The UIM may collect, store, process or disclose personal information relating to *Athletes* and other *Persons* where necessary and appropriate to conduct its *Anti-Doping Activities* under the *Code*, the *International Standards* (including specifically the *International Standard* for the Protection of Privacy and Personal Information), these Anti-Doping Rules, and in compliance with applicable law.
- 14.6.2** Without limiting the foregoing, the UIM shall:
  - (a) Only process personal information in accordance with a valid legal ground;
  - (b) Notify any *Participant* or *Person* subject to these Anti-Doping Rules, in a manner and form that complies with applicable laws and the *International Standard* for the Protection of Privacy and Personal Information, that their personal information may be processed by the UIM and other *Persons* for the purpose of the implementation of these Anti-Doping Rules;
  - (c) Ensure that any third-party agents (including any *Delegated Third Party*) with whom the UIM shares the personal information of any *Participant* or *Person* is subject to appropriate technical and contractual controls to protect the confidentiality and privacy of such information.

## ARTICLE 15 IMPLEMENTATION OF DECISIONS

### 15.1 Automatic Binding Effect of Decisions by *Signatory Anti-Doping Organizations*

- 15.1.1** A decision of an anti-doping rule violation made by a *Signatory Anti-Doping Organization*, an appellate body (Article 13.2.2 of the *Code*) or CAS shall, after the parties to the proceeding are notified, automatically be binding beyond the parties to the proceeding upon the UIM and its *National Authorities*, as well as every *Signatory* in every sport with the effects described below:
- 15.1.1.1** A decision by any of the above-described bodies imposing a *Provisional Suspension* (after a *Provisional Hearing* has occurred or the *Athlete* or other *Person* has either accepted the *Provisional Suspension* or has waived the right to a *Provisional Hearing*, expedited hearing or expedited appeal offered in accordance with Article 7.4.3) automatically prohibits the *Athlete* or other *Person* from participation (as described in Article 10.14.1) in all sports within the authority of any *Signatory* during the *Provisional Suspension*.
  - 15.1.1.2** A decision by any of the above-described bodies imposing a period of *Ineligibility* (after a hearing has occurred or been waived) automatically prohibits the *Athlete* or other *Person* from participation (as described in Article 10.14.1) in all sports within the authority of any *Signatory* for the period of *Ineligibility*.
  - 15.1.1.3** A decision by any of the above-described bodies accepting an anti-doping rule violation automatically binds all *Signatories*.
  - 15.1.1.4** A decision by any of the above-described bodies to *Disqualify* results under Article 10.10 for a specified period automatically *Disqualifies* all results obtained within the authority of any *Signatory* during the specified period.
- 15.1.2** The UIM and its *National Authorities* shall recognize and implement a decision and its effects as required by Article 15.1.1, without any further action required, on the earlier of the date the UIM receives actual notice of the decision or the date the decision is placed into ADAMS.
- 15.1.3** A decision by an *Anti-Doping Organization*, a national appellate body or CAS to suspend, or lift, *Consequences* shall be binding upon the UIM and its *National Authorities* without any further action required, on the earlier of the date the UIM receives actual notice of the decision or the date the decision is placed into ADAMS.
- 15.1.4** Notwithstanding any provision in Article 15.1.1, however, a decision of an anti-doping rule violation by a *Major Event Organization* made in an expedited process during an *Event* shall not be binding on the UIM or its *National Authorities* unless the rules of the *Major Event Organization* provide the *Athlete* or other *Person* with an opportunity to an appeal under non-expedited procedures.<sup>70</sup>

## 15.2 Implementation of Other Decisions by *Anti-Doping Organizations*

The UIM and its *National Authorities* may decide to implement other anti-doping decisions rendered by *Anti-Doping Organizations* not described in Article 15.1.1 above, such as a

<sup>70</sup> [Comment to Article 15.1.4: By way of example, where the rules of the *Major Event Organization* give the *Athlete* or other *Person* the option of choosing an expedited CAS appeal or a CAS appeal under normal CAS procedure, the final decision or adjudication by the *Major Event Organization* is binding on other *Signatories* regardless of whether the *Athlete* or other *Person* chooses the expedited appeal option.]

*Provisional Suspension* prior to a *Provisional Hearing* or acceptance by the *Athlete* or other *Person*.<sup>71</sup>

### 15.3 Implementation of Decisions by Body that is not a *Signatory*

An anti-doping decision by a body that is not a *Signatory* to the *Code* shall be implemented by the UIM and its *National Authorities*, if the UIM finds that the decision purports to be within the authority of that body and the anti-doping rules of that body are otherwise consistent with the *Code*.<sup>72</sup>

## ARTICLE 16 STATUTE OF LIMITATIONS

No anti-doping rule violation proceeding may be commenced against an *Athlete* or other *Person* unless he or she has been notified of the anti-doping rule violation as provided in Article 7, or notification has been reasonably attempted, within ten (10) years from the date the violation is asserted to have occurred.

## ARTICLE 17 EDUCATION

The UIM shall plan, implement, evaluate and promote *Education* in line with the requirements of Article 18.2 of the *Code* and the *International Standard for Education*.

The UIM may decide to request that *Athletes* complete *Educational* activities before and/or during their participation in select *Events* (e.g.: Youth World Championships) as a condition of such participation. The list of *Events* for which *Athletes* will be required to complete *Educational* activities as a condition of participation will be published on the UIM's website.

Failure by the *Athlete* to complete *Educational* activities as requested by the UIM may result in the imposition of sanction under the UIM's disciplinary rules, unless the *Athlete* provides to the UIM a justification for such failure, which shall be assessed by the UIM on a case by case basis.

## ARTICLE 18 ADDITIONAL ROLES AND RESPONSIBILITIES OF NATIONAL AUTHORITIES

**18.1** All *National Authorities* and their members shall comply with the *Code*, *International Standards*, and these Anti-Doping Rules. All *National Authorities* and other members shall include in their policies, rules and programs the provisions necessary to ensure that the UIM may enforce these Anti-Doping Rules (including carrying out *Testing*) directly in respect of *Athletes* (including *National-Level Athletes*) and other *Persons*

<sup>71</sup> [Comment to Articles 15.1 and 15.2: Anti-Doping Organization decisions under Article 15.1 are implemented automatically by other Signatories without the requirement of any decision or further action on the Signatories' part. For example, when a National Anti-Doping Organization decides to Provisionally Suspend an Athlete, that decision is given automatic effect at the International Federation level. To be clear, the "decision" is the one made by the National Anti-Doping Organization, there is not a separate decision to be made by the International Federation. Thus, any claim by the Athlete that the Provisional Suspension was improperly imposed can only be asserted against the National Anti-Doping Organization. Implementation of Anti-Doping Organizations' decisions under Article 15.2 is subject to each Signatory's discretion. A Signatory's implementation of a decision under Article 15.1 or Article 15.2 is not appealable separately from any appeal of the underlying decision. The extent of recognition of TUE decisions of other Anti-Doping Organizations shall be determined by Article 4.4 and the International Standard for Therapeutic Use Exemptions.]

<sup>72</sup> [Comment to Article 15.3: Where the decision of a body that has not accepted the Code is in some respects Code compliant and in other respects not Code compliant, the UIM, other Signatories and National Authorities should attempt to apply the decision in harmony with the principles of the Code. For example, if in a process consistent with the Code a non-Signatory has found an Athlete to have committed an anti-doping rule violation on account of the presence of a Prohibited Substance in the Athlete's body but the period of Ineligibility applied is shorter than the period provided for in the Code, then the UIM and all other Signatories should recognize the finding of an anti-doping rule violation and the Athlete's National Anti-Doping Organization should conduct a hearing consistent with Article 8 to determine whether the longer period of Ineligibility provided in the Code should be imposed. The UIM or other Signatory's implementation of a decision, or their decision not to implement a decision under Article 15.3, is appealable under Article 13.]

under their anti-doping authority as specified in the Introduction to these Anti-Doping Rules (Section “Scope of these Anti-Doping Rules”).

- 18.2** Each *National Authority* shall incorporate these Anti-Doping Rules either directly or by reference into its governing documents, constitution and/or rules as part of the rules of sport that bind their members so that the *National Authority* may enforce them itself directly in respect of *Athletes* (including *National-Level Athletes*) and other *Persons* under its anti-doping authority.
- 18.3** By adopting these Anti-Doping Rules, and incorporating them into their governing documents and rules of sport, *National Authorities* shall cooperate with and support the UIM in that function. They shall also recognize, abide by and implement the decisions made pursuant to these Anti-Doping Rules, including the decisions imposing sanctions on *Persons* under their authority.
- 18.4** All *National Authorities* shall take appropriate action to enforce compliance with the *Code*, *International Standards*, and these Anti-Doping Rules by *inter alia*:
- (i) conducting *Testing* only under the documented authority of the UIM and using their *National Anti-Doping Organization* or other *Sample* collection authority to collect *Samples* in compliance with the *International Standard* for *Testing* and *Investigations*;
  - (ii) recognizing the authority of the *National Anti-Doping Organization* in their country in accordance with Article 5.2.1 of the *Code* and assisting as appropriate with the *National Anti-Doping Organization’s* implementation of the national *Testing* program for their sport;
  - (iii) analysing all *Samples* collected using a *WADA*-accredited or *WADA*-approved laboratory in accordance with Article 6.1; and
  - (iv) ensuring that any national level anti-doping rule violation cases discovered by *National Authorities* are adjudicated by an *Operationally Independent* hearing panel in accordance with Article 8.1 and the *International Standard* for *Results Management*.
- 18.5** All *National Authorities* shall establish rules requiring all *Athletes* preparing for or participating in a *Competition* or activity authorized or organized by a *National Authority* or one of its member organizations, and all *Athlete Support Personnel* associated with such *Athletes*, to agree to be bound by these Anti-Doping Rules and to submit to the *Results Management* authority of the *Anti-Doping Organization* in conformity with the *Code* as a condition of such participation.
- 18.6** All *National Authorities* shall report any information suggesting or relating to an anti-doping rule violation to the UIM and to their *National Anti-Doping Organizations* and shall cooperate with investigations conducted by any *Anti-Doping Organization* with authority to conduct the investigation.
- 18.7** All *National Authorities* shall have disciplinary rules in place to prevent *Athlete Support Personnel* who are *Using Prohibited Substances* or *Prohibited Methods* without valid justification from providing support to *Athletes* under the authority of the UIM or the *National Authority*.
- 18.8** All *National Authorities* shall conduct anti-doping *Education* in coordination with their *National Anti-Doping Organizations*.

## **ARTICLE 19      ADDITIONAL Roles and responsibilities OF the UIM**

- 19.1** In addition to the roles and responsibilities described in Article 20.3 of the *Code* for International Federations the UIM shall report to *WADA* on the UIM’s compliance with the *Code* and the *International Standards* in accordance with Article 24.1.2 of the *Code*.

- 19.2** Subject to applicable law, and in accordance with Article 20.3.4 of the *Code*, all the UIM board members, directors, officers, employees and those of appointed *Delegated Third Parties* who are involved in any aspect of *Doping Control*, must sign a form provided by the UIM, agreeing to be bound by these Anti-Doping Rules as in *sons* in conformity with the *Code* for direct and intentional misconduct.
- 19.3** Subject to applicable law, and in accordance with Article 20.3.5 of the *Code*, any the UIM employee who is involved in *Doping Control* (other than authorized anti-doping *Education* or rehabilitation programs) must sign a statement provided by the UIM confirming that they are not *Provisionally Suspended* or serving a period of *Ineligibility* and have not been directly or intentionally engaged in conduct within the previous six (6) years which would have constituted a violation of anti-doping rules if *Code*-compliant rules had been applicable to them.

## **ARTICLE 20            ADDITIONAL ROLES AND RESPONSIBILITIES OF ATHLETES**

- 20.1** To be knowledgeable of and comply with these Anti-Doping Rules.
- 20.2** To be available for *Sample* collection at all times.<sup>73</sup>
- 20.3** To take responsibility, in the context of anti-doping, for what they ingest and *Use*.
- 20.4** To inform medical personnel of their obligation not to *Use Prohibited Substances* and *Prohibited Methods* and to take responsibility to make sure that any medical treatment received does not violate these Anti-Doping Rules.
- 20.5** To disclose to the UIM and their *National Anti-Doping Organization* any decision by a non-*Signatory* finding that the *Athlete* committed an anti-doping rule violation within the previous ten (10) years.
- 20.6** To cooperate with *Anti-Doping Organizations* investigating anti-doping rule violations. Failure by any *Athlete* to cooperate in full with *Anti-Doping Organizations* investigating anti-doping rule violations may result in a charge of misconduct under the UIM's disciplinary rules.
- 20.7** To disclose the identity of their *Athlete Support Personnel* upon request by the UIM or a *National Authority*, or any other *Anti-Doping Organization* with authority over the *Athlete*.
- 20.8** Offensive conduct towards a *Doping Control* official or other *Person* involved in *Doping Control* by an *Athlete*, which does not otherwise constitute *Tampering*, may result in a charge of misconduct under the UIM's disciplinary rules.

## **ARTICLE 21            ADDITIONAL ROLES AND RESPONSIBILITIES OF ATHLETE SUPPORT PERSONNEL**

- 21.1** To be knowledgeable of and comply with these Anti-Doping Rules.
- 21.2** To cooperate with the *Athlete Testing* program.
- 21.3** To use their influence on *Athlete* values and behavior to foster anti-doping attitudes.

<sup>73</sup> [Comment to Article 20.2: With due regard to an *Athlete's* human rights and privacy, legitimate anti-doping considerations sometimes require *Sample* collection late at night or early in the morning. For example, it is known that some *Athletes* Use low doses of EPO during these hours so that it will be undetectable in the morning.]

- 21.4** To disclose to the UIM and their *National Anti-Doping Organization* any decision by a non-*Signatory* finding that they committed an anti-doping rule violation within the previous ten (10) years.
- 21.5** To cooperate with *Anti-Doping Organizations* investigating anti-doping rule violations. Failure by any *Athlete Support Personnel* to cooperate in full with *Anti-Doping Organizations* investigating anti-doping rule violations may result in a charge of misconduct under the UIM's disciplinary rules.
- 21.6** *Athlete Support Personnel* shall not *Use* or *Possess* any *Prohibited Substance* or *Prohibited Method* without valid justification. Any such *Use* or *Possession* may result in a charge of misconduct under the UIM's disciplinary rules.
- 21.7** Offensive conduct towards a *Doping Control* official or other *Person* involved in *Doping Control* by *Athlete Support Personnel*, which does not otherwise constitute *Tampering*, may result in a charge of misconduct under the UIM's disciplinary rules.

## **ARTICLE 22      ADDITIONAL ROLES AND RESPONSIBILITIES OF OTHER PERSONS SUBJECT TO THESE ANTI-DOPING RULES**

- 22.1** To be knowledgeable of and comply with these Anti-Doping Rules.
- 22.2** To disclose to the UIM and their *National Anti-Doping Organization* any decision by a non-*Signatory* finding that they committed an anti-doping rule violation within the previous ten (10) years.
- 22.3** To cooperate with *Anti-Doping Organizations* investigating anti-doping rule violations. Failure by any other *Person* subject to these Anti-Doping Rules to cooperate in full with *Anti-Doping Organizations* investigating anti-doping rule violations may result in a charge of misconduct under the UIM's disciplinary rules.
- 22.4** Not to *Use* or *Possess* any *Prohibited Substance* or *Prohibited Method* without valid justification.
- 22.5** Offensive conduct towards a *Doping Control* official or other *Person* involved in *Doping Control* by a *Person*, which does not otherwise constitute *Tampering*, may result in a charge of misconduct under the UIM's disciplinary rules.

## **ARTICLE 23      INTERPRETATION OF THE CODE**

- 23.1** The official text of the *Code* shall be maintained by *WADA* and shall be published in English and French. In the event of any conflict between the English and French versions, the English version shall prevail.
- 23.2** The comments annotating various provisions of the *Code* shall be used to interpret the *Code*.
- 23.3** The *Code* shall be interpreted as an independent and autonomous text and not by reference to the existing law or statutes of the *Signatories* or governments.
- 23.4** The headings used for the various Parts and Articles of the *Code* are for convenience only and shall not be deemed part of the substance of the *Code* or to affect in any way the language of the provisions to which they refer.
- 23.5** Where the term "days" is used in the *Code* or an *International Standard*, it shall mean calendar days unless otherwise specified.

- 23.6** The *Code* shall not apply retroactively to matters pending before the date the *Code* is accepted by a *Signatory* and implemented in its rules. However, pre-*Code* anti-doping rule violations would continue to count as "First violations" or "Second violations" for purposes of determining sanctions under Article 10 for subsequent post-*Code* violations.
- 23.7** The Purpose, Scope and Organization of the World Anti-Doping Program and the *Code* and Appendix 1, Definitions, and Appendix 2, Examples of the Application of Article 10, shall be considered integral parts of the *Code*.

## ARTICLE 24 FINAL PROVISIONS

- 24.1** Where the term "days" is used in these Anti-Doping Rules, it shall mean calendar days unless otherwise specified.
- 24.2** These Anti-Doping Rules shall be interpreted as an independent and autonomous text and not by reference to existing law or statutes.
- 24.3** These Anti-Doping Rules have been adopted pursuant to the applicable provisions of the *Code* and the *International Standards* and shall be interpreted in a manner that is consistent with applicable provisions of the *Code* and the *International Standards*. The *Code* and the *International Standards* shall be considered integral parts of these Anti-Doping Rules and shall prevail in case of conflict.
- 24.4** The Introduction and Appendix 1 shall be considered integral parts of these Anti-Doping Rules.
- 24.5** The comments annotating various provisions of these Anti-Doping Rules shall be used to interpret these Anti-Doping Rules.
- 24.6** These Anti-Doping Rules entered into force on 1 January 2026 (the "Effective Date"). They repeal previous versions of the UIM's Anti-Doping Rules.
- 24.7** These Anti-Doping Rules shall not apply retroactively to matters pending before the Effective Date. However:
- 24.7.1** Anti-doping rule violations taking place prior to the Effective Date count as "first violations" or "second violations" for purposes of determining sanctions under Article 10 for violations taking place after the Effective Date.
- 24.7.2** Any anti-doping rule violation case which is pending as of the Effective Date and any anti-doping rule violation case brought after the Effective Date based on an anti-doping rule violation which occurred prior to the Effective Date, shall be governed by the substantive anti-doping rules in effect at the time the alleged anti-doping rule violation occurred, and not by the substantive anti-doping rules set out in these Anti-Doping Rules, unless the panel hearing the case determines the principle of "lex mitior" appropriately applies under the circumstances of the case. For these purposes, the retrospective periods in which prior violations can be considered for purposes of multiple violations under Article 10.9.4 and the statute of limitations set forth in Article 16 are procedural rules, not substantive rules, and should be applied retroactively along with all of the other procedural rules in these Anti-Doping Rules (provided, however, that Article 16 shall only be applied retroactively if the statute of limitation period has not already expired by the Effective Date).
- 24.7.3** Any Article 2.4 whereabouts failure (whether a filing failure or a missed test, as those terms are defined in the *International Standard for Results Management*) prior to the Effective Date shall be carried forward and may be relied upon, prior to expiry, in accordance with the *International Standard for*

*Results Management*, but it shall be deemed to have expired twelve (12) months after it occurred.

- 24.7.4** With respect to cases where a final decision finding an anti-doping rule violation has been rendered prior to the Effective Date, but the *Athlete* or other *Person* is still serving the period of *Ineligibility* as of the Effective Date, the *Athlete* or other *Person* may apply to the UIM or other *Anti-Doping Organization* which had *Results Management* responsibility for the anti-doping rule violation to consider a reduction in the period of *Ineligibility* in light of these Anti-Doping Rules. Such application must be made before the period of *Ineligibility* has expired. The decision rendered may be appealed pursuant to Article 13.2. These Anti-Doping Rules shall have no application to any case where a final decision finding an anti-doping rule violation has been rendered and the period of *Ineligibility* has expired.
- 24.7.5** For purposes of assessing the period of *Ineligibility* for a second violation under Article 10.9.1, where the sanction for the first violation was determined based on rules in force prior to the Effective Date, the period of *Ineligibility* which would have been assessed for that first violation had these Anti-Doping Rules been applicable, shall be applied.<sup>74</sup>
- 24.7.6** Changes to the *Prohibited List* and *Technical Documents* relating to substances or methods on the *Prohibited List* shall not, unless they specifically provide otherwise, be applied retroactively. As an exception, however, when a *Prohibited Substance* or *Prohibited Method* has been removed from the *Prohibited List*, an *Athlete* or other *Person* currently serving a period of *Ineligibility* on account of the formerly *Prohibited Substance* or *Prohibited Method* may apply to the UIM or other *Anti-Doping Organization* which had *Results Management* responsibility for the anti-doping rule violation to consider a reduction in the period of *Ineligibility* in light of the removal of the substance or method from the *Prohibited List*.

---

<sup>74</sup> [Comment to Article 24.7.5: Other than the situation described in Article 24.7.5, where a final decision finding an anti-doping rule violation has been rendered prior to the Effective Date and the period of *Ineligibility* imposed has been completely served, these Anti-Doping Rules may not be used to re-characterize the prior violation.]

## APPENDIX 2 DEFINITIONS

**ADAMS:** The Anti-Doping Administration and Management System is a Web-based database management tool for data entry, storage, sharing, and reporting designed to assist stakeholders and WADA in their anti-doping operations in conjunction with data protection legislation.

**Administration:** Providing, supplying, supervising, facilitating, or otherwise participating in the *Use* or *Attempted Use* by another *Person* of a *Prohibited Substance* or *Prohibited Method*. However, this definition shall not include the actions of bona fide medical personnel involving a *Prohibited Substance* or *Prohibited Method* Used for genuine and legal therapeutic purposes or other acceptable justification and shall not include actions involving *Prohibited Substances* which are not prohibited in *Out-of-Competition Testing* unless the circumstances as a whole demonstrate that such *Prohibited Substances* are not intended for genuine and legal therapeutic purposes or are intended to enhance sport performance.

**Adverse Analytical Finding:** A report from a WADA-accredited laboratory or other WADA-approved laboratory that, consistent with the *International Standard* for Laboratories, establishes in a *Sample* the presence of a *Prohibited Substance* or its *Metabolites* or *Markers* or evidence of the *Use* of a *Prohibited Method*.

**Adverse Passport Finding:** A report identified as an *Adverse Passport Finding* as described in the applicable *International Standards*.

**Aggravating Circumstances:** Circumstances involving, or actions by, an *Athlete* or other *Person* which may justify the imposition of a period of *Ineligibility* greater than the standard sanction. Such circumstances and actions shall include, but are not limited to: the *Athlete* or other *Person* *Used* or *Possessed* multiple *Prohibited Substances* or *Prohibited Methods*, *Used* or *Possessed* a *Prohibited Substance* or *Prohibited Method* on multiple occasions or committed multiple other anti-doping rule violations; a normal individual would be likely to enjoy the performance-enhancing effects of the anti-doping rule violation(s) beyond the otherwise applicable period of *Ineligibility*; the *Athlete* or *Person* engaged in deceptive or obstructive conduct to avoid the detection or adjudication of an anti-doping rule violation; or the *Athlete* or other *Person* engaged in *Tampering* during *Results Management*. For the avoidance of doubt, the examples of circumstances and conduct described herein are not exclusive and other similar circumstances or conduct may also justify the imposition of a longer period of *Ineligibility*.

**Anti-Doping Activities:** Anti-doping *Education* and information, test distribution planning, maintenance of a *Registered Testing Pool*, managing *Athlete Biological Passports*, conducting *Testing*, organizing analysis of *Samples*, gathering of intelligence and conduct of investigations, processing of *TUE* applications, *Results Management*, monitoring and enforcing compliance with any *Consequences* imposed, and all other activities related to anti-doping to be carried out by or on behalf of an *Anti-Doping Organization*, as set out in the *Code* and/or the *International Standards*.

**Anti-Doping Organization:** WADA or a *Signatory* that is responsible for adopting rules for initiating, implementing or enforcing any part of the *Doping Control* process. This includes, for example, the International Olympic Committee, the International Paralympic Committee, other *Major Event Organizations* that conduct *Testing* at their *Events*, International Federations, and *National Anti-Doping Organizations*.

**Athlete:** Any *Person* who competes in sport at the international level (as defined by each International Federation) or the national level (as defined by each *National Anti-Doping Organization*). An *Anti-Doping Organization* has discretion to apply anti-doping rules to an *Athlete* who is neither an *International-Level Athlete* nor a *National-Level Athlete*, and thus to bring them within the definition of “*Athlete*”. In relation to *Athletes* who are neither *International-Level* nor *National-Level Athletes*, an *Anti-Doping Organization* may elect to: conduct limited *Testing* or no *Testing* at all; analyse *Samples* for less than the full menu of *Prohibited Substances*; require limited or no whereabouts information; or not require advance *TUE*s. However, if an Article 2.1, 2.3 or 2.5 anti-doping rule violation is committed by any *Athlete* over whom an *Anti-Doping Organization* has elected to exercise its authority to test and who competes below the international or national level, then the *Consequences* set forth in the *Code* must be applied. For purposes of Article 2.8 and Article 2.9 and for purposes of anti-doping information and *Education*, any *Person* who participates in sport under the authority of any *Signatory*, government, or other sports organization accepting the *Code* is an *Athlete*.<sup>75</sup>

<sup>75</sup> [Comment to Athlete: Individuals who participate in sport may fall in one of five categories: 1) International-Level Athlete, 2) National-Level Athlete, 3) individuals who are not International- or National-Level Athletes but over whom the International Federation or National Anti-Doping Organization has chosen to exercise authority, 4) Recreational Athlete, and 5) individuals over whom no International Federation or National Anti-Doping Organization has, or has chosen to, exercise authority. All International- and National-Level Athletes are subject to the anti-doping rules of the Code, with the precise definitions of international and national level sport to be set forth in the anti-doping rules of the International Federations and National Anti-Doping Organizations.]

**Athlete Biological Passport:** The program and methods of gathering and collating data as described in the *International Standard for Testing and Investigations* and *International Standard for Laboratories*.

**Athlete Support Personnel:** Any coach, trainer, manager, agent, team staff, official, medical, paramedical personnel, parent or any other *Person* working with, treating or assisting an *Athlete* participating in or preparing for sports *Competition*.

**Attempt:** Purposely engaging in conduct that constitutes a substantial step in a course of conduct planned to culminate in the commission of an anti-doping rule violation. Provided, however, there shall be no anti-doping rule violation based solely on an *Attempt* to commit a violation if the *Person* renounces the *Attempt* prior to it being discovered by a third party not involved in the *Attempt*.

**Atypical Finding:** A report from a WADA-accredited laboratory or other WADA-approved laboratory which requires further investigation as provided by the *International Standard for Laboratories* or related *Technical Documents* prior to the determination of an *Adverse Analytical Finding*.

**Atypical Passport Finding:** A report described as an *Atypical Passport Finding* as described in the applicable *International Standards*.

**CAS:** The Court of Arbitration for Sport.

**Code:** The World Anti-Doping Code.

**Competition:** A single race, match, game or singular sport contest. For example, a basketball game or the finals of the Olympic 100-meter race in athletics. For stage races and other sport contests where prizes are awarded on a daily or other interim basis the distinction between a *Competition* and an *Event* will be as provided in the rules of the UIM.

**Consequences of Anti-Doping Rule Violations (“Consequences”):** An *Athlete’s* or other *Person’s* violation of an anti-doping rule may result in one or more of the following: (a) Disqualification means the *Athlete’s* results in a particular *Competition* or *Event* are invalidated, with all resulting *Consequences* including forfeiture of any medals, points and prizes; (b) Ineligibility means the *Athlete* or other *Person* is barred on account of an anti-doping rule violation for a specified period of time from participating in any *Competition* or other activity or funding as provided in Article 10.14; (c) Provisional Suspension means the *Athlete* or other *Person* is barred temporarily from participating in any *Competition* or activity prior to the final decision at a hearing conducted under Article 8; (d) Financial Consequences means a financial sanction imposed for an anti-doping rule violation or to recover costs associated with an anti-doping rule violation; and (e) Public Disclosure means the dissemination or distribution of information to the general public or *Persons* beyond those *Persons* entitled to earlier notification in accordance with Article 14. .

**Contaminated Product:** A product that contains a *Prohibited Substance* that is not disclosed on the product label or in information available in a reasonable Internet search.

**Decision Limit:** The value of the result for a threshold substance in a *Sample*, above which an *Adverse Analytical Finding* shall be reported, as defined in the *International Standard for Laboratories*.

**Delegated Third Party:** Any *Person* to which the UIM delegates any aspect of *Doping Control* or anti-doping *Education* programs including, but not limited to, third parties or other *Anti-Doping Organizations* that conduct *Sample* collection or other *Doping Control* services or anti-doping *Educational* programs for the UIM, or individuals serving as independent contractors who perform *Doping Control* services for the UIM (e.g., non-employee *Doping Control* officers or chaperones). This definition does not include CAS.

**Disqualification:** See *Consequences of Anti-Doping Rule Violations* above.

**Doping Control:** All steps and processes from test distribution planning through to ultimate disposition of any appeal and the enforcement of *Consequences*, including all steps and processes in between, including but not limited to *Testing*, investigations, whereabouts, *TUEs*, *Sample* collection and handling, laboratory analysis, *Results Management*, and investigations or proceedings relating to violations of Article 10.14 (Status During *Ineligibility* or *Provisional Suspension*).

**Education:** The process of learning to instill values and develop behaviors that foster and protect the spirit of sport, and to prevent intentional and unintentional doping.

**Event:** A series of individual *Competitions* conducted together under one ruling body (e.g., the Olympic Games, World Championships of an International Federation, or Pan American Games).

**Event Period:** The time between the beginning and end of an *Event*, as established by the ruling body of the *Event* (e.g. also specified in the *Advance Programme*).

**Event Venues:** Those venues so designated by the ruling body for the *Event*.

**Fault:** *Fault* is any breach of duty or any lack of care appropriate to a particular situation. Factors to be taken into consideration in assessing an *Athlete's* or other *Person's* degree of *Fault* include, for example, the *Athlete's* or other *Person's* experience, whether the *Athlete* or other *Person* is a *Protected Person*, special considerations such as impairment, the degree of risk that should have been perceived by the *Athlete* and the level of care and investigation exercised by the *Athlete* in relation to what should have been the perceived level of risk. In assessing the *Athlete's* or other *Person's* degree of *Fault*, the circumstances considered must be specific and relevant to explain the *Athlete's* or other *Person's* departure from the expected standard of behavior. Thus, for example, the fact that an *Athlete* would lose the opportunity to earn large sums of money during a period of *Ineligibility*, or the fact that the *Athlete* only has a short time left in a career, or the timing of the sporting calendar, would not be relevant factors to be considered in reducing the period of *Ineligibility* under Article 10.6.1 or 10.6.2.<sup>76</sup>

**Financial Consequences:** See *Consequences of Anti-Doping Rule Violations* above.

**In-Competition:** The period commencing at 11:59 p.m. on the day before a *Competition* in which the *Athlete* is scheduled to participate through the end of such *Competition* and the *Sample* collection process related to such *Competition*.

**Independent Observer Program:** A team of observers and/or auditors, under the supervision of WADA, who observe and provide guidance on the *Doping Control* process prior to or during certain *Events* and report on their observations as part of WADA's compliance monitoring program.

**Individual Sport:** Any sport that is not a *Team Sport*.

**Ineligibility:** See *Consequences of Anti-Doping Rule Violations* above.

**Institutional Independence:** Hearing panels on appeal shall be fully independent institutionally from the *Anti-Doping Organization* responsible for *Results Management*. They must therefore not in any way be administered by, connected or subject to the *Anti-Doping Organization* responsible for *Results Management*.

**International Event:** An *Event* or *Competition* where the International Olympic Committee, the International Paralympic Committee, an International Federation, a *Major Event Organization*, or another international sport organization is the ruling body for the *Event* or appoints the technical officials for the *Event*.

**International-Level Athlete:** *Athletes* who compete in sport at the international level, as defined by each International Federation, consistent with the *International Standard for Testing and Investigations*. For the sport of powerboating which includes Aquabike and Motosurfs disciplines, *International-Level Athletes* are defined as set out in the Scope section of the Introduction to these Anti-Doping Rules.<sup>77</sup>

**International Standard:** A standard adopted by WADA in support of the *Code*. Compliance with an *International Standard* (as opposed to another alternative standard, practice or procedure) shall be sufficient to conclude that the procedures addressed by the *International Standard* were performed properly. *International Standards* shall include any *Technical Documents* issued pursuant to the *International Standard*.

**Major Event Organizations:** The continental associations of *National Olympic Committees* and other international multi-sport organizations that function as the ruling body for any continental, regional or other *International Event*.

<sup>76</sup> [Comment to *Fault*: The criteria for assessing an *Athlete's* degree of *Fault* is the same under all Articles where *Fault* is to be considered. However, under Article 10.6.2, no reduction of sanction is appropriate unless, when the degree of *Fault* is assessed, the conclusion is that No Significant *Fault* or *Negligence* on the part of the *Athlete* or other *Person* was involved.]

<sup>77</sup> [Comment to *International-Level Athlete*: Consistent with the *International Standard for Testing and Investigations*, the UIM is free to determine the criteria it will use to classify *Athletes* as *International-Level Athletes*, e.g., by ranking, by participation in particular *International Events*, by type of license, etc. However, it must publish those criteria in clear and concise form, so that *Athletes* are able to ascertain quickly and easily when they will become classified as *International-Level Athletes*. For example, if the criteria include participation in certain *International Events*, then the *International Federation* must publish a list of those *International Events*.]

**Marker:** A compound, group of compounds or biological variable(s) that indicates the *Use of a Prohibited Substance or Prohibited Method*.

**Metabolite:** Any substance produced by a biotransformation process.

**Minimum Reporting Level:** The estimated concentration of a *Prohibited Substance* or its *Metabolite(s)* or *Marker(s)* in a *Sample* below which WADA-accredited laboratories should not report that *Sample* as an *Adverse Analytical Finding*.

**Minor:** A natural *Person* who has not reached the age of eighteen (18) years.

**National Anti-Doping Organization:** The entity(ies) designated by each country as possessing the primary authority and responsibility to adopt and implement anti-doping rules, direct the collection of *Samples*, the management of test results, and the conduct of hearings at the national level. If this designation has not been made by the competent public authority(ies), the entity shall be the country's *National Olympic Committee* or its designee.

**National Event:** A sport *Event* or *Competition* involving *International-* or *National-Level Athletes* that is not an *International Event*.

**National Authority:** A national or regional entity which is a member of or is recognized by the UIM as the entity governing the UIM's sport in that nation or region.

**National-Level Athlete:** *Athletes* who compete in sport at the national level, as defined by each *National Anti-Doping Organization*, consistent with the *International Standard for Testing and Investigations*.

**National Olympic Committee:** The organization recognized by the International Olympic Committee. The term *National Olympic Committee* shall also include the National Sport Confederation in those countries where the National Sport Confederation assumes typical *National Olympic Committee* responsibilities in the anti-doping area.

**No Fault or Negligence:** The *Athlete* or other *Person's* establishing that he or she did not know or suspect, and could not reasonably have known or suspected even with the exercise of utmost caution, that he or she had *Used* or been administered the *Prohibited Substance* or *Prohibited Method* or otherwise violated an anti-doping rule. Except in the case of a *Protected Person* or *Recreational Athlete*, for any violation of Article 2.1, the *Athlete* must also establish how the *Prohibited Substance* entered the *Athlete's* system.

**No Significant Fault or Negligence:** The *Athlete* or other *Person's* establishing that any *Fault* or *Negligence*, when viewed in the totality of the circumstances and taking into account the criteria for *No Fault or Negligence*, was not significant in relationship to the anti-doping rule violation. Except in the case of a *Protected Person* or *Recreational Athlete*, for any violation of Article 2.1, the *Athlete* must also establish how the *Prohibited Substance* entered the *Athlete's* system.

**Operational Independence:** This means that (1) board members, staff members, commission members, consultants and officials of the *Anti-Doping Organization* with responsibility for *Results Management* or its affiliates (e.g., member federation or confederation), as well as any *Person* involved in the investigation and pre-adjudication of the matter cannot be appointed as members and/or clerks (to the extent that such clerk is involved in the deliberation process and/or drafting of any decision) of hearing panels of that *Anti-Doping Organization* with responsibility for *Results Management* and (2) hearing panels shall be in a position to conduct the hearing and decision-making process without interference from the *Anti-Doping Organization* or any third party. The objective is to ensure that members of the hearing panel or individuals otherwise involved in the decision of the hearing panel, are not involved in the investigation of, or decisions to proceed with, the case.

**Out-of-Competition:** Any period which is not *In-Competition*.

**Participant:** Any *Athlete* or *Athlete Support Person*.

**Person:** A natural *Person* or an organization or other entity.

**Possession:** The actual, physical *Possession*, or the constructive *Possession* (which shall be found only if the *Person* has exclusive control or intends to exercise control over the *Prohibited Substance* or *Prohibited Method* or the premises in which a *Prohibited Substance* or *Prohibited Method* exists); provided, however, that if the *Person* does not have exclusive control over the *Prohibited Substance* or *Prohibited Method* or the premises in which a *Prohibited Substance* or *Prohibited Method* exists, constructive *Possession* shall only be found if the *Person* knew about the presence of the *Prohibited Substance* or *Prohibited Method* and intended to exercise control over it. Provided, however, there shall be no anti-doping rule violation based solely on *Possession* if, prior to receiving notification of any kind that the *Person* has committed an anti-doping rule violation, the *Person* has taken concrete

action demonstrating that the *Person* never intended to have *Possession* and has renounced *Possession* by explicitly declaring it to an *Anti-Doping Organization*. Notwithstanding anything to the contrary in this definition, the purchase (including by any electronic or other means) of a *Prohibited Substance* or *Prohibited Method* constitutes *Possession* by the *Person* who makes the purchase.<sup>78</sup>

*Prohibited List*: The List identifying the *Prohibited Substances* and *Prohibited Methods*.

*Prohibited Method*: Any method so described on the *Prohibited List*.

*Prohibited Substance*: Any substance, or class of substances, so described on the *Prohibited List*.

*Protected Person*: An *Athlete* or other natural *Person* who at the time of the anti-doping rule violation: (i) has not reached the age of sixteen (16) years; (ii) has not reached the age of eighteen (18) years and is not included in any *Registered Testing Pool* and has never competed in any *International Event* in an open category; or (iii) for reasons other than age has been determined to lack legal capacity under applicable national legislation.<sup>79</sup>

*Provisional Hearing*: For purposes of Article 7.4.3, an expedited abbreviated hearing occurring prior to a hearing under Article 8 that provides the *Athlete* with notice and an opportunity to be heard in either written or oral form.<sup>80</sup>

*Provisional Suspension*: See *Consequences of Anti-Doping Rule Violations* above.

*Publicly Disclose*: See *Consequences of Anti-Doping Rule Violations* above.

*Recreational Athlete*: A natural *Person* who is so defined by the relevant *National Anti-Doping Organization*; provided, however, the term shall not include any *Person* who, within the five (5) years prior to committing any anti-doping rule violation, has been an *International-Level Athlete* (as defined by each International Federation consistent with the *International Standard for Testing and Investigations*) or *National-Level Athlete* (as defined by each *National Anti-Doping Organization* consistent with the *International Standard for Testing and Investigations*), has represented any country in an *International Event* in an open category or has been included within any *Registered Testing Pool* or other whereabouts information pool maintained by any International Federation or *National Anti-Doping Organization*.<sup>81</sup>

*Regional Anti-Doping Organization*: A regional entity designated by member countries to coordinate and manage delegated areas of their national anti-doping programs, which may include the adoption and implementation of anti-doping rules, the planning and collection of *Samples*, the management of results, the review of *TUEs*, the conduct of hearings, and the conduct of *Educational* programs at a regional level.

*Registered Testing Pool*: The pool of highest-priority *Athletes* established separately at the international level by International Federations and at the national level by *National Anti-Doping Organizations*, who are subject to focused *In-Competition* and *Out-of-Competition Testing* as part of that International Federation's or *National Anti-Doping Organization's* test distribution plan and therefore are required to provide whereabouts information as provided in Article 5.5 and the *International Standard for Testing and Investigations*.

*Results Management*: The process encompassing the timeframe between notification as in Article 5 of the *International Standard for Results Management*, or in certain cases (e.g., *Atypical Finding*, *Athlete Biological Passport*, whereabouts failure), such pre-notification steps expressly provided for in Article 5 of the *International*

<sup>78</sup> [Comment to *Possession*: Under this definition, anabolic steroids found in an *Athlete's* car would constitute a violation unless the *Athlete* establishes that someone else used the car; in that event, the *UIM* must establish that, even though the *Athlete* did not have exclusive control over the car, the *Athlete* knew about the anabolic steroids and intended to have control over them. Similarly, in the example of anabolic steroids found in a home medicine cabinet under the joint control of an *Athlete* and spouse, the *UIM* must establish that the *Athlete* knew the anabolic steroids were in the cabinet and that the *Athlete* intended to exercise control over them. The act of purchasing a *Prohibited Substance* alone constitutes *Possession*, even where, for example, the product does not arrive, is received by someone else, or is sent to a third party address.]

<sup>79</sup> [Comment to *Protected Person*: The Code treats *Protected Persons* differently than other *Athletes* or *Persons* in certain circumstances based on the understanding that, below a certain age or intellectual capacity, an *Athlete* or other *Person* may not possess the mental capacity to understand and appreciate the prohibitions against conduct contained in the Code. This would include, for example, a Paralympic *Athlete* with a documented lack of legal capacity due to an intellectual impairment. The term "open category" is meant to exclude competition that is limited to junior or age group categories.]

<sup>80</sup> [Comment to *Provisional Hearing*: A *Provisional Hearing* is only a preliminary proceeding which may not involve a full review of the facts of the case. Following a *Provisional Hearing*, the *Athlete* remains entitled to a subsequent full hearing on the merits of the case. By contrast, an "expedited hearing", as that term is used in Article 7.4.3, is a full hearing on the merits conducted on an expedited time schedule.]

<sup>81</sup> [Comment to *Recreational Athlete*: The term "open category" is meant to exclude competition that is limited to junior or age group categories.]

*Standard for Results Management*, through the charge until the final resolution of the matter, including the end of the hearing process at first instance or on appeal (if an appeal was lodged).

*Sample or Specimen*: Any biological material collected for the purposes of *Doping Control*.<sup>82</sup>

*Signatories*: Those entities accepting the *Code* and agreeing to implement the *Code*, as provided in Article 23 of the *Code*.

*Specified Method*: See Article 4.2.2.

*Specified Substance*: See Article 4.2.2.

*Strict Liability*: The rule which provides that under Article 2.1 and Article 2.2, it is not necessary that intent, *Fault*, *Negligence*, or knowing *Use* on the *Athlete's* part be demonstrated by the *Anti-Doping Organization* in order to establish an anti-doping rule violation.

*Substance of Abuse*: See Article 4.2.3.

*Substantial Assistance*: For purposes of Article 10.7.1, a *Person* providing *Substantial Assistance* must: (1) fully disclose in a signed written statement or recorded interview all information he or she possesses in relation to anti-doping rule violations or other proceeding described in Article 10.7.1.1, and (2) fully cooperate with the investigation and adjudication of any case or matter related to that information, including, for example, presenting testimony at a hearing if requested to do so by an *Anti-Doping Organization* or hearing panel. Further, the information provided must be credible and must comprise an important part of any case or proceeding which is initiated or, if no case or proceeding is initiated, must have provided a sufficient basis on which a case or proceeding could have been brought.

*Tampering*: Intentional conduct which subverts the *Doping Control* process but which would not otherwise be included in the definition of *Prohibited Methods*. *Tampering* shall include, without limitation, offering or accepting a bribe to perform or fail to perform an act, preventing the collection of a *Sample*, affecting or making impossible the analysis of a *Sample*, falsifying documents submitted to an *Anti-Doping Organization* or *TUE* committee or hearing panel, procuring false testimony from witnesses, committing any other fraudulent act upon the *Anti-Doping Organization* or hearing body to affect *Results Management* or the imposition of *Consequences*, and any other similar intentional interference or *Attempted* interference with any aspect of *Doping Control*.<sup>83</sup>

*Target Testing*: Selection of specific *Athletes* for *Testing* based on criteria set forth in the *International Standard for Testing and Investigations*.

*Team Sport*: A sport in which the substitution of players is permitted during a *Competition*.

*Technical Document*: A document adopted and published by *WADA* from time to time containing mandatory technical requirements on specific anti-doping topics as set forth in an *International Standard*.

*Testing*: The parts of the *Doping Control* process involving test distribution planning, *Sample* collection, *Sample* handling, and *Sample* transport to the laboratory.

*Testing Pool*: The tier below the *Registered Testing Pool* which includes *Athletes* from whom some whereabouts information is required in order to locate and *Test* the *Athlete Out-of-Competition*.

*Therapeutic Use Exemption (TUE)*: A *Therapeutic Use Exemption* allows an *Athlete* with a medical condition to *Use* a *Prohibited Substance* or *Prohibited Method*, but only if the conditions set out in Article 4.4 and the *International Standard for Therapeutic Use Exemptions* are met.

*Trafficking*: Selling, giving, transporting, sending, delivering or distributing (or *Possessing* for any such purpose) a *Prohibited Substance* or *Prohibited Method* (either physically or by any electronic or other means) by an *Athlete*, *Athlete Support Person* or any other *Person* subject to the authority of an *Anti-Doping Organization* to any third

<sup>82</sup> [Comment to *Sample or Specimen*: It has sometimes been claimed that the collection of blood *Samples* violates the tenets of certain religious or cultural groups. It has been determined that there is no basis for any such claim.]

<sup>83</sup> [Comment to *Tampering*: For example, this Article would prohibit altering identification numbers on a *Doping Control* form during *Testing*, breaking the *B* bottle at the time of *B* *Sample* analysis, altering a *Sample* by the addition of a foreign substance, or intimidating or attempting to intimidate a potential witness or a witness who has provided testimony or information in the *Doping Control* process. *Tampering* includes misconduct which occurs during the *Results Management* and hearing process. See Article 10.9.3.3. However, actions taken as part of a *Person's* legitimate defense to an anti-doping rule violation charge shall not be considered *Tampering*. Offensive conduct towards a *Doping Control* official or other *Person* involved in *Doping Control* which does not otherwise constitute *Tampering* shall be addressed in the disciplinary rules of sport organizations.]

party; provided, however, this definition shall not include the actions of bona fide medical personnel involving a *Prohibited Substance* Used for genuine and legal therapeutic purposes or other acceptable justification, and shall not include actions involving *Prohibited Substances* which are not prohibited in *Out-of-Competition Testing* unless the circumstances as a whole demonstrate such *Prohibited Substances* are not intended for genuine and legal therapeutic purposes or are intended to enhance sport performance.

*UNESCO Convention*: The International Convention against Doping in Sport adopted by the 33<sup>rd</sup> session of the UNESCO General Conference on 19 October 2005 including any and all amendments adopted by the States Parties to the Convention and the Conference of Parties to the International Convention against Doping in Sport.

*Use*: The utilization, application, ingestion, injection or consumption by any means whatsoever of any *Prohibited Substance* or *Prohibited Method*.

*WADA*: The World Anti-Doping Agency.

*Without Prejudice Agreement*: For purposes of Articles 10.7.1.1 and 10.8.2, a written agreement between an *Anti-Doping Organization* and an *Athlete* or other *Person* that allows the *Athlete* or other *Person* to provide information to the *Anti-Doping Organization* in a defined time-limited setting with the understanding that, if an agreement for *Substantial Assistance* or a case resolution agreement is not finalized, the information provided by the *Athlete* or other *Person* in this particular setting may not be used by the *Anti-Doping Organization* against the *Athlete* or other *Person* in any *Results Management* proceeding under the *Code*, and that the information provided by the *Anti-Doping Organization* in this particular setting may not be used by the *Athlete* or other *Person* against the *Anti-Doping Organization* in any *Results Management* proceeding under the *Code*. Such an agreement shall not preclude the *Anti-Doping Organization*, *Athlete* or other *Person* from using any information or evidence gathered from any source other than during the specific time-limited setting described in the agreement.



# ENVIRONMENTAL CODE 2026



The UIM Environmental Code  
has been acknowledged by RINA and allowed the UIM to be  
nominated  
"2011 GREEN  
ASSOCIATION"

## TABLE OF CONTENTS

<b>ENVIRONMENTAL CODE .....</b>	<b>182</b>
TABLE OF CONTENTS .....	183
1.GENERAL PRINCIPLES .....	184
2.UIM ENVIRONMENTAL WORKING GROUP (EWG).....	185
3.ENVIRONMENTAL STEWARD.....	186
4.UIM ENVIRONMENTAL DELEGATE.....	186
5.NOISE .....	187
6.FUEL .....	188
7.PROTECTION OF GROUND AND WATER .....	188
8.CLEANING OF POWERBOATS .....	188
9.ACTION TO BE TAKEN BY DRIVERS / PARTICIPANTS.....	188
10.REQUIREMENTS TO ENCOURAGE ENVIRONMENTAL BEHAVIOUR BY THE SPECTATORS .....	189
11.ACTION TO BE TAKEN BY INTERNATIONAL ORGANIZERS.....	189
12.RECOMMENDATIONSTOALLSEA/LAKE/RIVER USERS .....	192
13.UIM ENVIRONMENTAL AWARD.....	192
14.UIM TRIANNUAL WORLD CIRCUMNAVIGATION RACE .....	192
15.GREEN LOGO .....	192

## **1.GENERAL PRINCIPLES**

### **1.1**

Powerboat activities fall into three main categories: Competition, recreation and transport. This Code includes competitive activities for members running the UIM racing classes included the UIM rulebooks for offshore, circuit, pleasure navigation and aqua bike. The Code is a working document until fully adopted by the UIM General Assembly.

### **1.2**

Competitive powerboat racing events are a major constituent of the International and national sporting calendars, attracting an increasing audience and producing significant economic effects. It is a sport which, like most other sports, and human activities in general, creates an impact on the environment.

### **1.3**

Power boating activities in general, as a means of transport or for recreation, continues to increase, and therefore must also be looked at from an environmental point of view. The UIM will do its best to transfer best practices from competitive power boating to these other areas.

### **1.4**

The UIM considers it to be of major importance to develop a coherent environmental policy, taking into account the legislative and regulatory requirements of each country.

### **1.5**

The UIM will seek to establish at all times the highest environmental standards during the organization of powerboat events at all levels and will promote environmental consciousness among all powerboat racers. The UIM will do so in close co-operation with the *National* Authorities and all involved stakeholders.

### **1.6**

The UIM environment policy, as defined in this *Code*, is based on mutual respect of the needs of the environment and of reasonable practices of powerboat sports and powerboat driving in general.

### **1.7**

The UIM seeks close co-operation with International authorities and organizations in order to ensure that there are sufficient facilities for powerboat activities in environmentally acceptable conditions and encourages its member nations to do so at national, regional and local level.

### **1.8**

All national federations affiliated to the UIM shall do their best efforts in order to give proper prominence to environmental matters and to the principles of the UIM Environmental *Code*.

## 1.9

According to the above general principles, this *Code* prescribes regulations and recommendations to improve the relationship between Power boating competitions and the environment.

These regulations and recommendations refer in particular to:

- a) Climate emissions in cooperation with guidelines given from the UNEP and minimize to reach zero emissions in the future.
- b) Noise, fuel and protection of the water
- c) Behaviour of the spectators, organizers, officers and race participants in order to maintain the highest possible standards worldwide

## 1.10

The UIM encourage all national authorities to issue guidelines in line with the above and taking into considerations o regional and national legislations.

## 1.11

The non respect of a requirement of the UIM Environmental *Code* by an organizer or a racer or the *Person* responsible for his/her racing team is liable to a fine, a *Disqualification* from the *Event* or a suspension. Moreover, the *Participant/Driver/pilot* may be liable for the damages caused by his/her non-respect of the environmental provisions.

## **2.UIM ENVIRONMENTAL WORKING GROUP (EWG)**

### **2.1 ROLE AND RESPONSIBILITIES**

The Environmental Group role is to advise the UIM on what policy should be adopted in terms of environmental protection, alternative energies and support for sustainable development and, through its members, support the UIM programs and activities in this field.

- Raise awareness on environment, alternative energies and sustainable development among UIM *National* Authorities and UIM stakeholders
- Disseminate knowledge and ensure know-how transfer in the above areas
- Promote environmental responsibility in the planning and staging of UIM events
- Ensure compliance of UIM affiliated members with the Environmental *Code*
- Promote the creation of an Environmental Working Group within *National Federations*
- Organize environmental seminars and establish a high profile network of correspondents
- Prepare an annual environmental report
- Presentation of the EWG work and findings at the UIM Council and General Assembly
- Advice the national environmental working groups on how to tackle environmental issues
- Liaise with external institutions such as public authorities, environmental organizations and other sporting bodies

### **3.ENVIRONMENTAL STEWARD**

#### **3.1 ROLE AND RESPONSIBILITIES**

At the UIM titled events there should be an official called the Environmental Steward who shall deal only with environmental aspects and who must have successfully completed a seminar organized by the UIM Environmental Working Group (hereafter EWG).

- Ensure that the UIM Environmental *Code* is respected.
- Have access to all information concerning the *Event*, and must be able to give prior, during and after the *Event*, recommendations to the OOD on all aspects of the *Event* which may have potential environmental consequences.
- Draw up in an appropriate manner a report on the basis of a check-list and send it to the UIM Secretariat. A copy should also be handed to the OOD and the UIM Environmental Delegate if present at the *Event*. In case of a first non-respect of this point, the Environmental Steward will receive a warning from the UIM or its national federation. In case of a second offence, the UIM may pronounce against the Environmental Steward a suspension of up to 12 months.
- Instruct officials during national seminars for the various disciplines, as well as for racers and organizers.
- In case of non-respect or violation of the provisions mentioned in the present *Code*, he must immediately first inform the OOD.

### **4.UIM ENVIRONMENTAL DELEGATE**

The UIM Environmental Delegate is a member of and is nominated by the EWG. There is a need to find the premises for the Environmental Delegate to be able to operate. The UIM Commissioner will handle the environmental observations on title championships and include the observations in their report.

- Observe and verify the application of the Environmental *Code*.
- Inform the OOD of any violation of the Environmental *Code* in order to pronounce sanctions relative to the infraction.
- Identify areas of “good practice” and make recommendations or proposals of modifications of the Environmental *Code*.
- Perform inspections of the racecourse and its facilities at any time before, during or after the *Event*.
- Prepare a report summing up all important aspects of the *Event* that relate to the environment.
- Any serious failure of the Environmental Steward towards the obligations and due diligence mentioned in article 2 of the present *Code* noticed by the UIM Environmental Delegate will be examined and, in case of need, sanctioned by the EWG with withdrawal of the Environmental Steward’s license for a period of up to 12 months.

An educational program is mandatory for the UIM environmental delegates.

## **5.NOISE**

### **5.1 INTRODUCTION**

Concerns regarding noise at powerboat events are not limited to the machines themselves. In addition to the expected engine noise, organizers and environmental stewards must be aware of the magnitude of sound from public address systems, crowds and other sources associated with an *Event*. Minimizing excessive noise associated with powerboat activity and taking public reaction to noise in consideration is the responsibility of all concerned: *Drivers*, clubs, organizers and officials.

### **5.2 NOISE OF POWERBOATS**

Sound is a measurable phenomenon created when a source, such as a powerboat engine, causes the air to vibrate. In contrast, noise is an individual interpretation of the impact of that sound. A sound enjoyed by one may be annoying or even harmful to another. Powerboats with high sound levels are almost always considered noisy. The Environmental Steward must understand the difference between the two and how sound is quantified. The decibel (dB) is the unit used to express sound pressure levels and they are measured on several scales. Powerboat sound is tested on the “A” weighted scale and is expressed as dB (A). Sound pressure levels increase at a logarithmic rate (very quickly) while the human ear interprets that increase more slowly. As a consequence, each time the number of identical sound sources is doubled (as with many powerboats at the starting line), the sound pressure level measurement is increased by only 3 dB(A). Sound levels decrease as the distance from the source increases. A doubling of the distance from the source to the ear causes a loss of 6 dB (A). Temperature, geography, elevation, humidity and the frequency of the sound waves also contribute to the rate of energy loss. Such things as foliage, uneven ground and sea and large obstacles, such as walls, cars or embankments will reflect sound and affect sound levels in the immediate area.

The UIM recommends:

- a) To avoid all unnecessary running of engines.
- b) To reduce as much as possible the sound levels in all disciplines and ensure that all applicable regulations are strictly respected.
- c) The UIM shall always promote research on the question of sound level in relation to powerboat sports.
- d) The UIM will aim to set regulations stipulating the maximum permitted noise levels for each class. Noise levels should be set for the different classes in cooperation with the different commissions. When the limit has been set the regulations shall be monitored and sanctioned strictly.

### **5.3 SOUND LEVEL MEASUREMENTS**

Environmental Stewards and *Event* organizers should be familiar with local ordinances governing both *Event* and powerboat sound levels. For details of specific sound levels for each discipline refer to the relevant rules. The UIM noise control method and sound levels are also recommended for national or club events.

### **5.4 PUBLIC ADDRESS SYSTEM**

- a) Separate public-address systems for *Drivers'* paddock and the public areas/enclosures are preferable and should never produce a higher sound than the hearing damage threshold level 83 dB(A) when measured in a public area and should also not exceed 3 dB(A) above the background and sea sound levels when measured at the nearest dwelling house.
- b) Position of loud-speakers: slanted towards the ground and directed towards the centre of the course.
- c) Maintain sound level as low as possible. The whole system must be ready and tested 30 minutes before the start of the practice. The sound system often causes more annoyance outside the track area than the actual event. Make arrangements with the people in charge of the sound system to reduce the sound volume between races/practice sessions.

## **6.FUEL**

It is recommended that regular unleaded fuel, available at the service stations, or other cleaner fuels provided by the organizers, without additives, except oil for two stroke engines, is used.

The use of alternative energies such as bio fuels, hydrogen or electricity, as long as they are not more noxious for the environment, must be encouraged for all disciplines in conformity with the relevant technical regulations. For the purposes of protecting the environment, provisions regarding fuel storage mentioned in the relevant rules must be respected.

Transition implementation – When a Class has more than 50% of the entries using EPA engines at a World Championship then the non EPA engines are phased out.

For details, refer to the technical rules of the various sporting disciplines.

## **7.PROTECTION OF GROUND AND WATER**

- a) Measures must be taken to prevent leaks of fuel, oil, cleaning, degreasing, cooling and brake fluids, etc. into the ground and water or vapour into the air.
- b) Containers/facilities to recover rubbish, oils, chemicals, detergents, etc. must be provided.
- c) The Use of an environmental mat, (or other effective device) protecting the ground and water, is compulsory to be used where servicing of machines is permitted by the organizer, amongst others in the paddock and repair areas. Any infraction of this rule will be reported to the OOD who will fine the Driver/pilot responsible a maximum of USD 1000 or any other amount mentioned in the regulation or appendix of the discipline.
- d) Provision must be made for the treatment of spillage and the disposal of contaminated material by the organizers.
- e) It is strictly forbidden to empty onto the ground and water waste fluids from vehicles or boats located in the Drivers' paddock and the campsite. Waste water may only be disposed of at the circuit a proper facility to this effect. Any infraction to this rule will be reported to the OOD who will fine the Driver/pilot responsible a maximum of USD 500. Other sanctions may be pronounced by the OOD or the UIM Commissioner.
- f) Do not leave on the spot sustainable evidence of any Event, club or boating activity.

### **7.1 ENVIRONMENTAL MAT**

The Environmental Mat is compulsory for all disciplines. It must be composed of an absorbent part and an impermeable part. Its Use will be compulsory everywhere where work on powerboats is allowed by the organizers.

## **8.CLEANING OF POWERBOATS**

- a) Cleaning of engine and motor parts, where permitted by the regulations, must only be carried out at places with cleaning facilities.
- b) Only certified non toxic solvent, without the addition of chemical products (for example detergent), is permitted when cleaning the boats.
- c) The cleaning area must be built with a non-porous surface and a proper drain with an oil-divider to prevent pollution of the ground and water. Any infraction of this rule will be reported to the Officer of the Day (OOD) who will fine the Driver/pilot responsible a maximum of USD 500. – or any other amount mentioned in the regulation or appendix of the discipline.

## **9.ACTION TO BE TAKEN BY DRIVERS / PARTICIPANTS**

- a) Each Driver is responsible for the waste generated by his/her team during the event.
- b) Where organizers provide the necessary containers for waste they must be used as directed.
- c) Waste must be retained by the team until the approved facilities provided by organizers can be used.

- d) Where refuelling or servicing of a powerboat is being undertaken at events, Driver/participants must provide and Use an environment mat to protect the ground and water. This environmental mat must also be compulsory when an electrical generator or any other device with a thermal engine is used by the driver/pilot or the team. These mats must be removed by the driver/pilots/competitors after Use.
- e) Any infringement by the Participant or Driver/pilot (who is responsible for his/her team) of the UIM regulations can result in a fine, Disqualification from the event or suspension, and may also result in the participant or driver/pilot being liable for any costs of rectification.

## **10.REQUIREMENTS TO ENCOURAGE ENVIRONMENTAL BEHAVIOUR BY THE SPECTATORS**

Visitors to a powerboat circuit, track, event or gathering can play an important role in keeping the environment clean and undamaged. Here are some suggestions:

- a) In co-operation with the local authorities, select the routes to and from circuits, tracks, etc., which will cause as little annoyance as possible for the surrounding areas.
- b) Provide clear signs to circuits, tracks and venues.
- c) Avoid parking on vulnerable places (verges, green lanes).
- d) Avoid parking in long grass.
- e) Promote the Use of public transportation in publications and promotional releases i.e. web or other forums.
- f) Avoid too high concentrations of people in order to preserve vulnerable places i.e. wildlife and bird reservation.
- g) Provide sufficient sanitary facilities and safe cleaning and deposit systems.
- h) Inform the spectators about responsible behaviour on the site.
- i) Specify in contracts with catering firms a requirement to sell drinks and food packaged in recyclable, reusable or biodegradable material, and to provide and maintain sufficient waste containers. Promote cooperation with caterers that have high standards on ethical and ecological food.
- j) Manage the events in such a way that only footsteps remain on the soil.

## **11.ACTION TO BE TAKEN BY INTERNATIONAL ORGANIZERS**

Promote environmental behaviour among all Persons involved within the organization and promote environmentally friendly work within the secretariat and the Administration to save paper and energy.

Venues creating participants more than 50 and/or spectators more 20 000, shall make a more comprehensive written environmental plan including the following points:

1. Use of resources (energy, chemicals and materials)
2. Impact on environment and climate emissions
3. Carbon offsetting all activities related to events from
4. Recycling and reduction of waste
5. Travelling and accommodation for spectators and guests
6. Birds, animals and wildlife
7. Visual environment

Any organizer of an event under the authority of the UIM is subject to its regulation and jurisdiction. Any clearly established infraction or inobservance of the prescriptions and obligations for the organizers are subject to the penalties laid down in the present Environmental Code or in other UIM disciplinary procedures.

Infringement of Article 11 will be reported to the UIM ExCO who can fine the organizer a minimum of USD 1000 or any other amount mentioned in the regulation or appendix of the specific discipline.

## 11.1 ENVIRONMENTAL PROVISIONS

Make arrangements to prevent pollution of the ground and water in the Drivers' dry/wet pits and surrounding areas. Look after the protection of verges along the access roads, parking, and fencing off (tape) vulnerable areas. The facilities for practice, racing, gatherings and the surroundings must be protected as much as possible from pollution and annoyance. Having regard to the expected number of spectators, provide and maintain sufficient and clean sanitation, with proper provisions for waste and water.

Measures must also be taken to prevent:

- a) Leakage of fuel, oil, cleaning, degreasing, cooling and brake fluids, etc. into the ground and water or vapour into the air.
- b) Waste from participants, their teams, spectators and selling points not being collected in waste-bins or containers and being left on the ground and water at the site.
- c) Sanitary facilities being connected improperly to the sewerage.
- d) Waste collected and removed in an illegal way.
- e) UIM sound levels for powerboats during practice or Event being exceeded.
- f) Inordinate sound levels at tourist gatherings.
- g) The maximum number of events and/or practicing time being exceeded.

## 11.2 LOGBOOK / CHECK-LIST

It is important for every motor sport Event organizer to maintain a "logbook" in which is written all activities and measures that have been taken, what meetings have taken place and with whom, what permissions have been sought and those that have been granted relative to the Use and maintenance of the facilities for powerboat sport or other event. If permission is only given for Use of the facilities for a certain period of time, the exact time when it is in Use must also be noted. Together with the logbook it is useful to Use a check-list for the management of the facilities, to stimulate an environment friendly behaviour by the spectators and an environment friendly Use of the facilities during events. This check-list must include at least the following points:

- a) An assessment of the environmental impact of the event on the circuit and its surroundings, having regard to the number of competitors and the expected number of spectators.
- b) Cleaning area with high-pressure cleaners for powerboats.
- c) Distribution of waste bags to participants and their teams.
- d) Containers for used oil, cooling fluid or any other liquid.
- e) Containers for spectators' general litter.
- f) Sanitary facilities.
- g) Judicious positioning of loud speakers.
- h) Provision of adequate and appropriate direction signs to the event.
- i) Provision of containers or waste bags in the pits of the mechanics' area and collection of the contents during and after the event.

## 11.3 PUBLICITY/ADVERTISING

- a) The UIM suggest aggressive Use of the Web and media instead of prints/posters on paper.
- b) Do not attach posters to trees, in country areas and/or protected urban-sites nor in places and areas which are not appropriate.
- c) Place billboards only after having obtained permission from the owner of the property.
- d) Take local and governmental regulations into account when placing billboards.
- e) Do not distribute leaflets/pamphlets under windscreen wipers of cars, on powerboats, nor to spectators (do not allow others to do so during your event).

## 11.4 DRIVER PADDOCK / SERVICE AREAS / TIME CONTROL AREAS

- a) Present every participant on arrival with a rubbish bag and instructions.
- b) Provide sufficient containers for the rubbish bags and set recycling stations accessible to the public and participating teams.
- c) Ensure that there are enough containers with fixed funnels to collect used oil.
- d) Provide recognizable containers for oil filters and cleaning rags; collect separately.
- e) Provide and maintain sufficient and clean sanitation, with proper provisions for waste and water, for both men and women.
- f) If cleaning of powerboats is allowed, a special wash area designed to ensure the ground and water is not polluted must be provided in accordance with the rules of the discipline concerned.
- g) The Use of an environmental mat is compulsory when a generator or any other device with a thermal engine is used.

## 11.5 AFTER THE EVENT

- a) Signposts, billboards and posters must be removed after the event.
- b) Waste left behind on the site and the surroundings must be cleaned up and removed as soon as possible.
- c) Clear away and dispose of any broken branches or shrubs.
- d) Clear away tape, buoys and rope/weights around the track.
- e) Arrange for separate removal of oil-containers, cleaning rags, oil filters and waste-containers.
- f) The infraction or inobservance by the organizer of obligations mentioned in the present Environmental Code are subject to sanctions laid down in this Code and can result in a fine or suspension of approval to organize UIM events. The organizer will also be liable for any costs of rectification.

## 11.6 GENERAL REGULATIONS FOR THE MANAGEMENT OF VENUES

- a) Keep up the maintenance of the venue and take care that it is kept clean and tidy at all times.
- b) Cordon off sensitive areas.
- c) Appoint a member of the Organizing Board to be in charge of all environmental aspects and maintain the environment logbook.
- d) Ensure proper disposal of waste from sanitary facilities.
- e) Take all necessary care when making changes/adjustments to the site and consult the appropriate authorities.
- f) When locating the starting areas, take acoustic impacts into account.
- g) Never Use building waste, rubble, etc. for the construction of noise barriers, etc.
- h) In case of the Use of materials from outside, have them checked by the appropriate authorities to ensure that they are not polluted.
- i) Following every Event and at regular intervals, make an evaluation of the impact of the Event on the environment; make a report of it in the logbook; and make recommendations to correct any shortcomings and errors.

## **12.RECOMMENDATIONSTOALLSEA/LAKE/RIVER USERS**

### **12.1 INTRODUCTION**

We must voluntarily moderate and add a greater degree of responsibility to our natural desire for individual mobility. We should try to achieve results on the basis of freedom of thought and movement, and exploit every opportunity to combine the pleasure of Powerboating more effectively with ecological and economic needs.

### **12.2 DRIVER CONDUCT**

- a) Individual power boaters should develop driving habits to ensure full integration with other types of sea, lake and river users.
- b) Ride safely and avoid aggressive driving.
- c) Save petrol and reduce pollution by avoiding unnecessary idling of engines.
- d) Limit noise pollution
- e) Noise annoyance. Use exhaust system (towards/into water) which minimize noise and keep audio systems at a low level.
- f) Protect wildlife and its natural habitat
- g) Ensure that your used oil, batteries and other recyclable items are properly recycled or collected.
- h) Remember that our seas/lakes/ivers belong to the overall community.

## **13.UIM ENVIRONMENTAL AWARD**

In order to encourage a greater awareness of environmental concerns, the UIM has created an Environmental Award to reward a significant contribution to the protection of the environment. This Award may be given each year according to the following rules:

- a) By "year", the EWG understands that the year taken into consideration to award the prize starts on 1 January and ends on 30 September. The candidatures must arrive at the UIM Secretariat by the 5 October at the latest.
- b) This distinction is granted for rewarding individuals, clubs, organizers, manufacturers or other organizations that have made a significant contribution or done something important to enhance environmental awareness in the field of Power boating
- c) Candidatures for the Environmental Award will be submitted to the UIM by October 5<sup>th</sup> at the latest. The EWG may also propose a candidate.
- d) The candidatures received will be examined by the UIM Environment Group prior to submitting them to the ExCo. The recipient can be invited to the UIM GA to receive his/her (their) distinction.
- e) These nominations should be submitted, along with a description of the occurrence qualifying for the Award, to the UIM Secretariat within the set deadline

## **14.UIM TRIANNUAL WORLD CIRCUMNAVIGATION RACE**

Every three years the UIM may organize a world circumnavigation race. The race shall be performed on alternative energy and sustainability principles.

### **15.GREEN LOGO**



The UIM have approved this Green Logo

© (2026) Copyright by UIM - Union Internationale Motonautique. All rights reserved. No part of this document/publication may be reproduced, distributed, or transmitted in any form or by any means without the prior written consent of the UIM, except for the non-commercial use within the scope of authority of the UIM and its affiliated members.



**UIM**

[uim@uim.sport](mailto:uim@uim.sport)